



---

USES AND  
RACOMMENDS



[www.tmracing.it](http://www.tmracing.it)

---

TM Racing SpA - Via Fano, 6  
61122 Pesaro - ITALY  
Phone: +39 0721 25113

**2T125EN25**

**2T 125 ES EN**

29/11/2024



## INFORMAZIONI GENERALI

Il presente catalogo serve per richiedere con esattezza le parti di ricambio.

Nelle ordinazioni indicare:

**1) Il numero di matricola del Telaio** che è stampigliato sul lato destro del canotto di sterzo. Nei modelli EN, SMR, SMR il numero di matricola è riportato anche su una targhetta posta sul lato sinistro (Vedi foto).

**2) il numero di serie del Motore.** E' posto sulla sinistra del motore tra la leva cambio e i coperchio accensione (Vedi foto).

**3) Il codice dei particolari** seguito dalla descrizione.

**4) Il colore per i pezzi verniciati o comunque colorati.**

Le indicazioni destra e sinistra si riferiscono ai lati del veicolo rispetto al senso di marcia.

Foto e disegni sono solo a scopo informativo e potrebbero non corrispondere esattamente alle caratteristiche dei prodotti.

## GENERAL INFORMATION

The present spare parts catalogue enables one to order exactly the right spare part.

When ordering specify:

**1) The frame serial number.** It is embossed on the right side of the steering metal tube. In the EN, SMR and SMR models, the serial number is also stated on a plate positioned on the left hand side (See photo).

**2) The engine serial number.** It is located on the left side of the engine between the gear lever and the ignition cover (See photo).

**3) The part's code number** followed but its description.

**4) Indicate colour** for painted or colored parts.

References to right and left apply to the vehicle in terms of its direction of movement.

Photos and drawings are for informational purposes only and may not exactly match the characteristics of the products.

## NOTE – LEGENDA

**MY**

NOVITA' INTRODOTTA DIFFERENTE O NON PRESENTE NEL MODELLO DELL'ANNO PRECEDENTE

*PART DIFFERENT OR NOT PRESENT IN THE REVIOUS YEAR MODEL*

**5M**

MOTORE CON CAMBIO A 5 MARCE  
ENGINE WITH 5 GEARS SPEED

**6M**

MOTORE CON CAMBIO A 6 MARCE  
ENGINE WITH 6 GEARS SPEED

**KS**

MOTORE CON SOLO KICK STARTER  
ENGINE WITH KICK STARTER ONLY

**ES**

MOTORE CON AVVIAMENTO ELETTRICO  
ENGINE WITH ELECTRIC STARTER

**X**

RICAMBIO NON DISPONIBILE ALLA VENDITA  
PART CAN NOT BE SOLD SEPARATELY

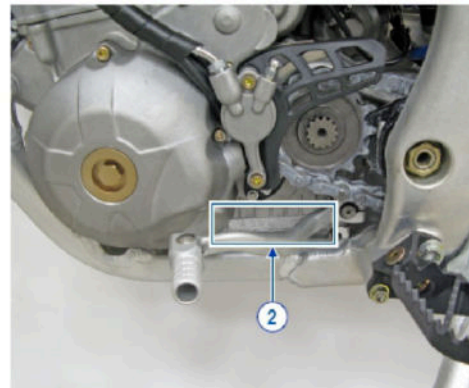
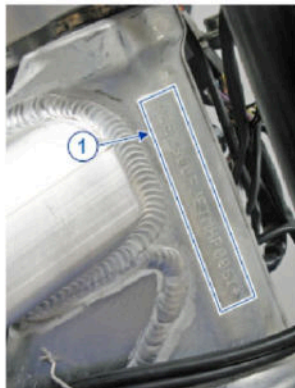

Le illustrazioni riportate in questo manuale sono fornite solo come riferimento e possono variare dal prodotto effettivo,

Dati indicativi soggetti a modifiche senza impegno di preavviso.

The illustrations in this manual are for reference only and may vary from the actual product.

All data are subject to modification without prior notice.



**2T125EN25**  
**2T 125 ES EN**

**SOMMARIO**  
**TABLE OF CONTENTS**

MANUBRIO - HANDLEBAR.....	5
FRENO ANTERIORE - FRONT BRAKE.....	7
FORCELLA - FORNT FORK.....	9
RUOTA ANTERIORE - FRONT WHEEL.....	12
RADIATORI - RADIATORS.....	14
TELAIO - FRAME.....	16
PLASTICHE E SELLA - PLASTIC AND SEAT.....	19
CASSA FILTRO - AIRBOX.....	21
FORCELLONE - SWINGARM.....	23
LEVERAGGI EN +1 - LINKAGE EN +1.....	25
RUOTA POSTERIORE 18x1.85 - REAR WHEEL 18x1.85.....	27
FRENO POSTERIORE - REAR BRAKE.....	30
SCARICO - EXHAUST SYSTEM.....	33
CABLAGGI - EXHAUST.....	35
IMPIANTO LUCI - LIGHTING SYSTEM.....	37
CONTA KM + CLACSON - SPEEDOMETER + HORN.....	39
KIT ADESIVI EN.....	41
CILINDRO 01 - 125 MX/EN CARB. - CYLINDER 01 - 125 MX/EN CARB.....	43
CILINDRO 02 - 125 MX/EN CARB. - CYLINDER 02 - 125 MX/EN CARB.....	45
ALBERO MOTORE E PISTONE - CRANKSHAFT AND PISTON.....	48
ACCENSIONE CARBURATORE.....	50
FRIZIONE - CLUTCH.....	52



**2T125EN25**  
**2T 125 ES EN**

**SOMMARIO**  
**TABLE OF CONTENTS**

CARTER FRIZIONE - CLUTCH CASE.....	55
BASAMENTO E PACCO - CASE AND REEDS BOX.....	57
COMANDO CAMBIO - GEARSHIFT MECHANISM.....	59
CAMBIO EN/SMR - GEARBOX.....	62
VITI MOTORE - BOLTS.....	65
MONO TM.....	67
CARBURATORE KEIHIN PWK 38 - CARBURETTOR KEIHIN PWK 38.....	71



2T125EN25  
2T 125 ES EN

MANUBRIO  
HANDLEBAR

1

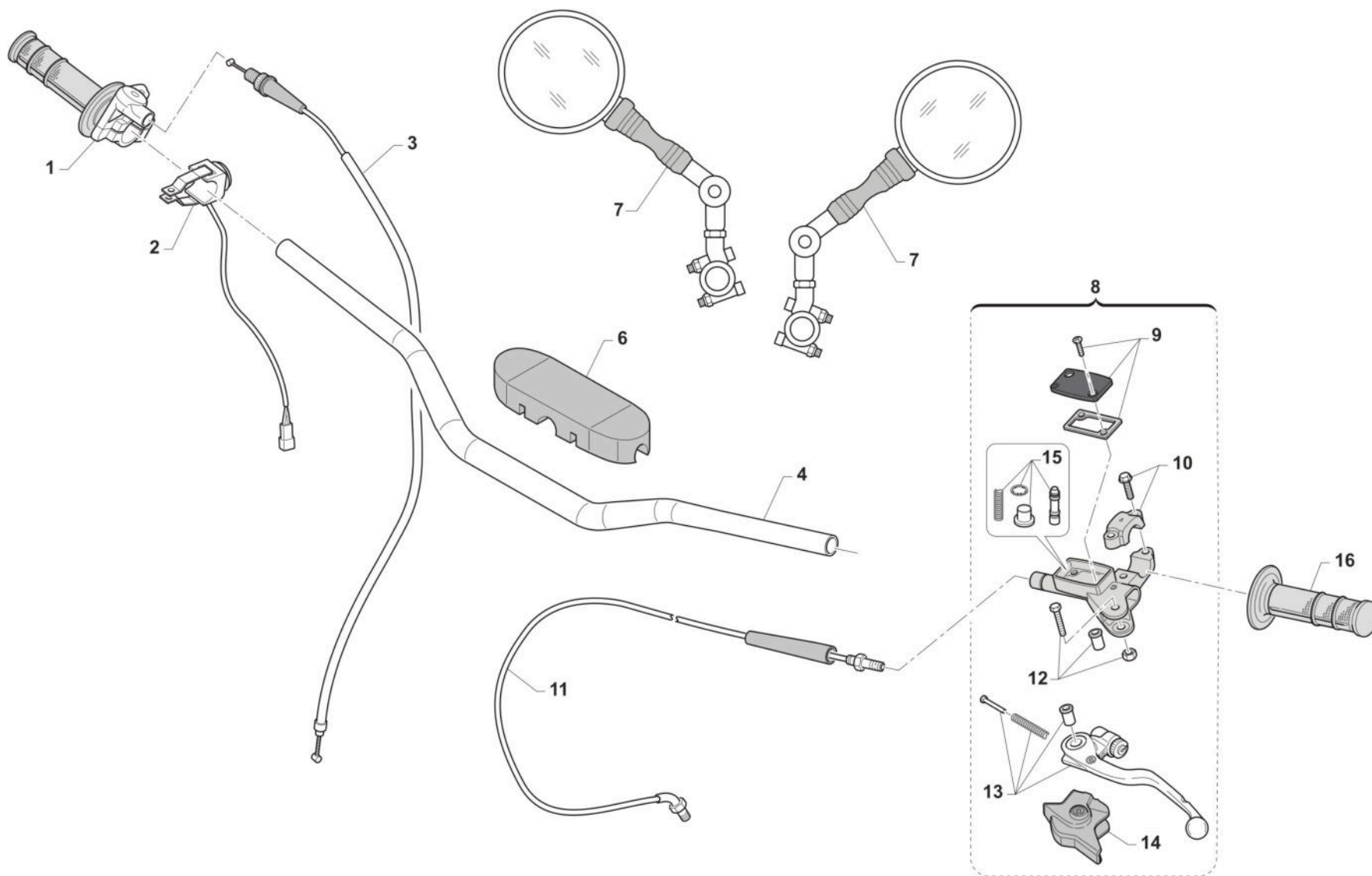

TM 0639.03



2T125EN25  
2T 125 ES EN

MANUBRIO  
HANDLEBAR

1

Pos.	Codice	Q.tà	Note	Descrizione	Description
1	64017	1		COMANDO GAS DOMINO MOD. 99->	THROTTLE ASSY DOMINO 2S 99/->
2	68244	1		PULSANTE AVVIAMENTO MOTO ES MY19->	BUTTON, START BIKE E.S. M. 19->
3	64036.08	1		CAVO GAS 2T MY 99/07 + MY 08/->	THROTTLE CABLE 2S M.08/->
4	64085	1		MANUBRIO TM RACING 9012 TL	
6	64078.1	1		PARACOLPI MANUBRIO TM 2013 NR	PROTECTION FOR HANDLEBAR TM BLACK
7	64200	2		SPECCHIETTO RETROVISORE	REAR-VIEW MIRROR
8	69360	1		POMPA FRIZIONE PS 9/17.7 BREMBO	PUMP, CLUTCH PS 9/17.7 BREMBO
9	64266	1		COPERCH./MEMBRAN.P.FRIZ.BREMBO 69360	
10	69362	1		CAVALLOTTO POMPA FRENO ANT PS10/16	HOLDER
11	35302	1		TUBO FRIZ.IDR. 2T 250/300 2T MY 19->+ 2T 125/144 MY 02/->	HYDR. CLUTCH HOSE 250/300 TS M.19->
12	64245	1		PERNO LEVA POMPA FRIZ. BREMBO	PIN
13	64241	1		LEVA FRIZIONE BREMBO RICAMBIO	LEVER, CLUTCH BREMBO
14	64238	1		PARAPOLVERE POMPA FRIZIONE BR.	DUST SEAL,CLUTCH MASTER CYL.BR
15	64265	1		FLOTTANTE POMPA FRIZ. BREMBO 69360 9/17	
16	64087	1		MANOPOLE COPPIA CIRCUIT IV (AZZURRO)	



2T125EN25  
2T 125 ES EN

FRENO ANTERIORE  
FRONT BRAKE

2

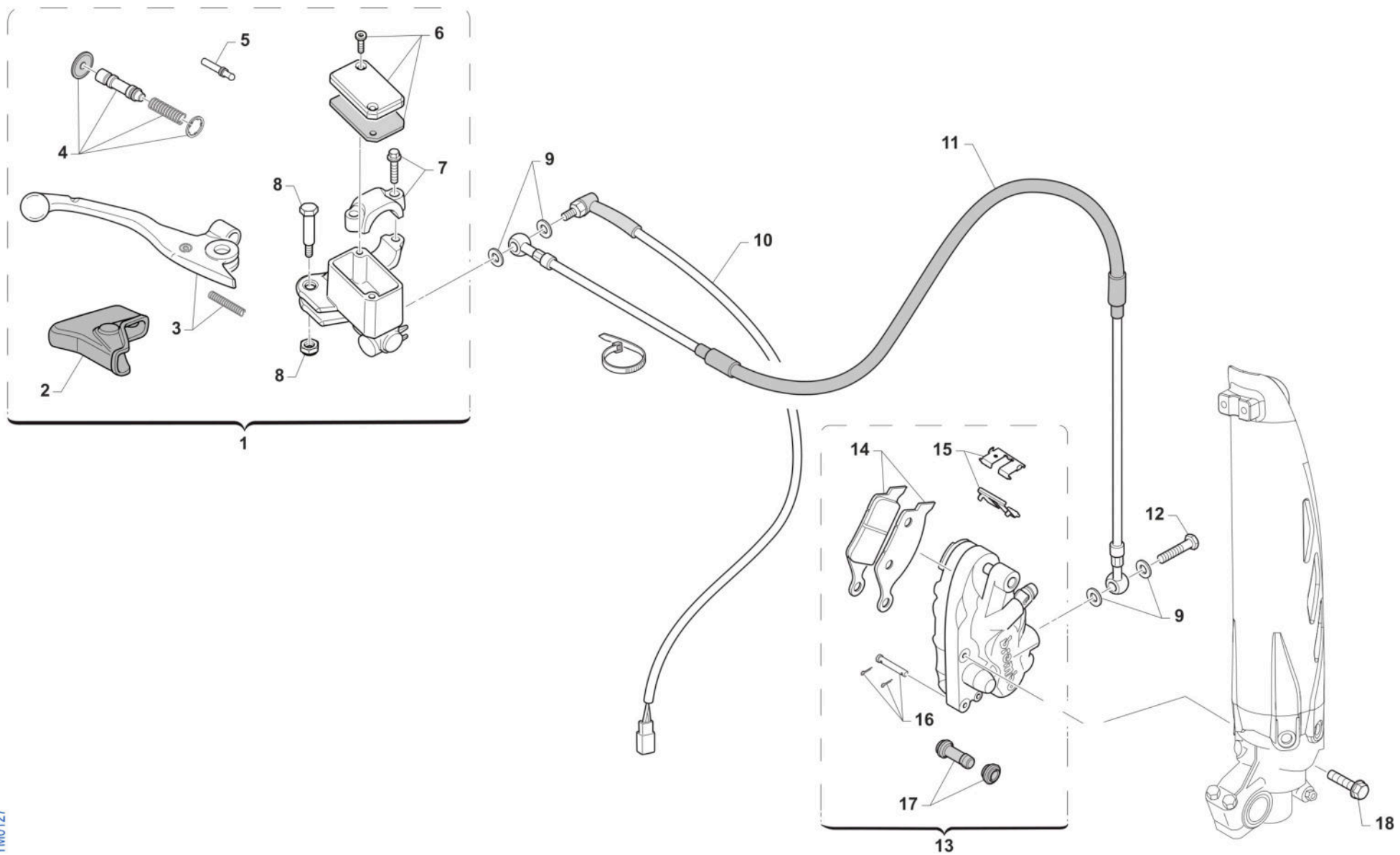

TM0127



2T125EN25  
2T 125 ES EN

FRENO ANTERIORE  
FRONT BRAKE

2

Pos.	Codice	Q.tà	Note	Descrizione	Description
1	69248	1		POMPA FRENO ANT PS10/16 BREMBO (opt.JUNIOR)	FRONT MASTER CYLINDER PS 10/16 BREMBO
2	69363	1		CAPPUCCIO POMPA FRENO ANT PS10/16	RUBBER FRONT MASTER CYLINDER BREMBO
3	69357	1		LEVA FRENO ANT BR. X 69248	BRAKE FRONT LEVER BREMBO X 69248
4	69358	1		KIT FLOTTANTE POMPA FREN.69248	CYLINDER AND RUBBER KIT 69248
5	69364	1		PUNTALINO POMPA FRENO ANT PS10/16	PUSH ROD
6	69368	1		TAPPO POMPA FRENO BREMBO 69248	CAP
7	69362	1		CAVALLOTTO POMPA FRENO ANT PS10/16	HOLDER
8	69365	1		PERNO LEVA POMPA FRENO ANT PS10/16	PIN, LEVER
9	69034	4		RONDELLA X BULLONE FREN B22001	WASHER B22001, BRAKE HOSE
10	68060	1		INTERRUT. IDR. STOP BREMBO 90 GRADI	SWITCH,IDR.STOP REAR BR.BREMBO
11	69042.14	1		TUBO FRENO ANT END 08/-> WHITE	HOSE, FR BRAKE END 08-> WHITE
12	69093	1		BULLONE 10X1 TUBO FRENO BREMBO 03	HOLLOW SCREW M10X1 BREMBO BR.
13	69222	1		PINZA FRENO ANTERIORE KYB PF2	CALIPER, FRONT BRAKE XKYB PF2
14	69107	1		PASTIGLIE ANTE. M.92/14 BREMBO	PAD KIT, FR BRAKE BREMBO 92/->
14	69117	1		PASTIGLIE ANT.M.92/11 SINT.TOS	PADS, FRONT BRAKE 92->11 SINT.
15	69273	1		LAMIERINO PINZA 69222	RETAINER BRAKE PADS 69222
16	69274	1		PERNO PINZA ANT. 69222	PIN, BRAKE PADS
17	69113	1		CUFFIE PINZA ANT/POST 92/98	COVER, RUBBER CALIPER 92/98
18	49365	1		VITE TE F/R 8X35 Ch.10	BOLT 8X35 T.10mm





2T125EN25  
2T 125 ES EN

FORCELLA  
FORNT FORK

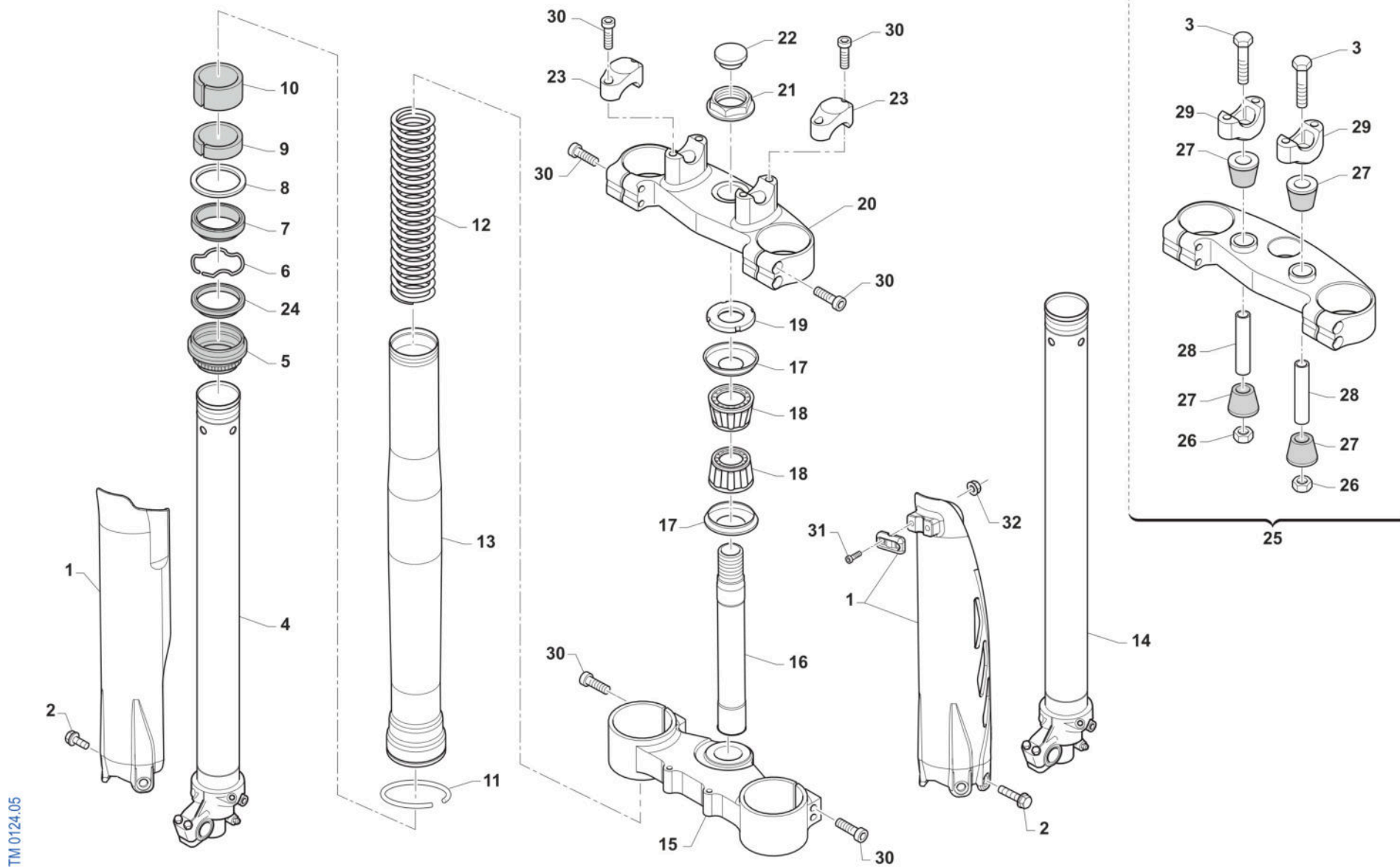

TM 0124-05



2T125EN25  
2T 125 ES EN

FORCELLA  
FORNT FORK

3

Pos.	Codice	Q.tà	Note	Descrizione	Description
1	67471	1		PROTEZ.KIT FORC.USD QUANTUM 2025	
2	49571	6		VITE TBCE 6 x 7 PROT. FORCELLA	BOLT TBCE 6x7
3	49582	2		VITE TE 10X65 UNI 5737	SCREW EH 10X65
4	72568	1		INNER TUBE COMP RIGHT	INNER TUBE COMP RIGHT
5	72502	2		PARAPOLVERE FORCELLA KYB 48 mm	DUST SEAL KYB FORK 48 mm
6	72525	2		SNAP RING OIL SEAL KYB 48 MM	SNAP RING OIL SEAL KYB 48 MM
7	72501	2		PARAOLIO FORCELLA KYB 48 mm	OIL SEAL KYB FORK 48 mm
8	72526	2		WASHER NEXT TO OIL SEAL KYB 48	WASHER NEXT TO OIL SEAL KYB 48
9	72504	2		SLIDE METAL KYB 48 mm	SLIDE METAL KYB 48
10	72503	2		PISTON METAL KYB 48 mm	PISTON METAL KYB 48
11	72530	2		SNAP RING OUTERTUBE KYB 48 MM	SNAP RING OUTERTUBE KYB 48 MM
12	72392	2		SPRING 4.3 N/mm FORC. KYB	
12	72393	2		SPRING 4.4 N/mm FORC. KYB	
12	72394	2		SPRING 4.5 N/mm FORC. KYB	
12	72395	2		SPRING 4.8 N/mm FORC. KYB	
12	F72445	2		MOLLA FORCELLA KAYABA 48 K=4.0	SPRING, FORKS KYB 48 K=4.0
13	72567.1	2		OUTER TUBE COMP (FODERO) COL. ORO Kashima Gold	OUTER TUBE COMP, GOLD
14	72569	1		INNER TUBE COMP LEFT	INNER TUBE COMP LEFT
15	72000.101	1		PIASTRA INF. KYB 48,22	
15	72000.72	1		PIASTRA INF. KYB 48,23	BOTTOM TRIPLE CLAMP KYB 48,23
16	72031	1		CANOTTO STERZO FERRO END 98/->	STEERING STEM, END. M.98/04
17	72002.02	2		PROTEZIONE CUSC/CANOTTO STERZO M. 02 ->	DUST SEAL, STEERING STEM 02/->
18	03070	2		CUSCINETTO CONICO STERZO 02/->	BUSH, STEERING M. 02/->
19	72008.98	1		GHIERA STERZO FORC.MOTO 98/04	NUT, STEERING BEARING
20	72000.100	1		PIASTRA SUP. KYB 48,22	
20	72000.71	1		PIASTRA SUP. KYB 48,23	BOTTOM TRIPLE CLAMP KYB 48,23
21	49080	1		DADO CANOTTO STERZO 98/-> ALL	NUT, STEERING STEM ALUM 98/->
22	21033	1		TAPPO PLAST.D25 -CANOT.STER.EN	PLASTIC CAP D.25mm STEER. AXE



2T125EN25  
2T 125 ES EN

FORCELLA  
FORNT FORK

3

Pos.	Codice	Q.tà	Note	Descrizione	Description
23	72036.11	2		CAVALLOTTO SUP.M.11 SILVER	UPPER HANDLEBAR M.11 SILVER
24	72341	2		SCRAPER FORC.KYB R.DEPT	SCRAPER
25	72000.109	1		PIASTRA SUP. KYB 48,22 SB CPL	
25	72000.78	1		PIASTRA SUP. KYB 48,23 SB CPL	TOP TRIPLE CLAMP SB KYB 48,23
26	49646	2		DADO M10 BASSO AUTOBLOCCANTE	NUT, M10 LOW SELF-LOCKING
27	21036	4		GOMMINO CAVAL. ANTIVIB.MANUBRIO MY 05->	RUBBER, HANDLEBAR 05/->
28	26106	2		TUBETTO CAV.ANT.VIB.12X45X10	BUSH, RUBBER, TRIPLE CLAMP
29	72037.11	2		CAVALLOTTO INF. 11 RP SB SILVER	LOWER HANDLEBAR, CNC S.B. M11
30	49502	8		VITE TCEI 8X30	BOLT TCEI 8X30
31	49474	2		VITE TCEI 5X16 UNI 5931	BOLT TCEI 5X16
32	49629	2		DADO M 5 ALTO AUTOBLOCCANTE	NUT 5mm, HIGHT SELF-LOCKING



2T125EN25  
2T 125 ES EN

RUOTA ANTERIORE  
FRONT WHEEL

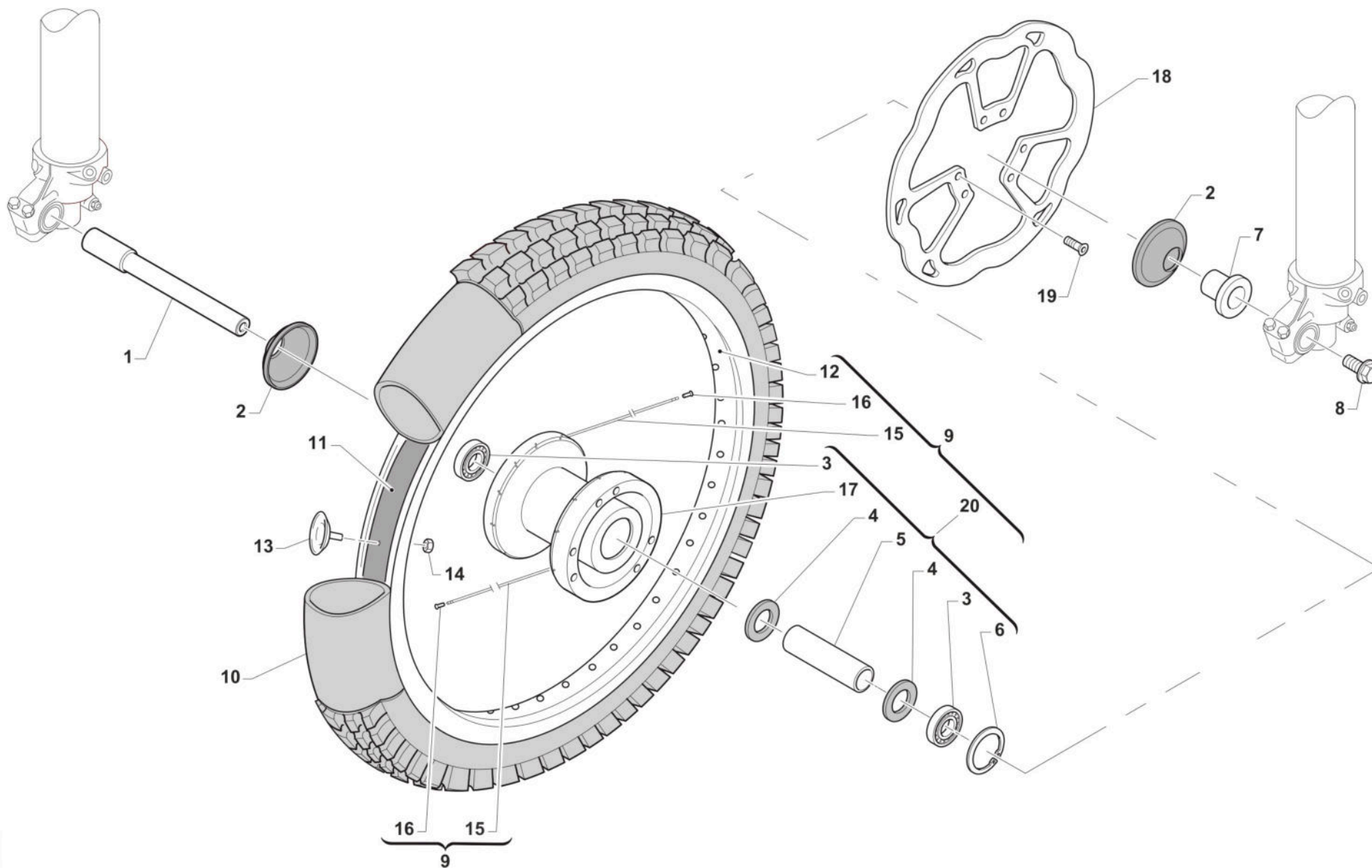

TM0017



2T125EN25  
2T 125 ES EN

RUOTA ANTERIORE  
FRONT WHEEL

4

Pos.	Codice	Q.tà	Note	Descrizione	Description
1	74044	1		PERNO RUOTA ANT MA50 07/->	AXLE, FR WHEEL MA50 07/->
2	69998	2		PARAPOLVERE RUOTA ANT. MARZ. KYB 07->	DUST SEAL, FR WHEEL MA50 07/->
3	03071	2		CUSCINETTO RUOTA ANTER. + POSTER.	BUSH, FRONT WHEEL MA50 61905
4	70165	2		RONDELLA GOMMA 42X29X3 D.I.ANT	WASHER, RUBBER 42x29x3
5	70167	1		DIST.INT.R.ANT. MARZOCCHI 07	SPACER INTER.FRONT WHEEL MA.7
6	49250	1		SEEGER I 42 RP 94/96 ANT MARZ.50	CIRCLIP D.42 - REAR WHEEL
7	70166	1		BOCCOLA RUOTA ANT MA50 07/->	SPACER, FR WHEEL MA50 07/->
8	49077	1		DADO PERNO RUOTA ANT M.K.07->	NUT, FR AXLE MA50 M.07/->
9	70191	1		CERCHIO ANT. CPL 21x1.60 MA50/KYB48 BLU	RIM, FRONT MX ASSY 21x1.60 MY10->
10	80150	1		CAMERA ARIA ANTERIORE 21	TUBE, TYRE 21
11	70032	1		FLAP RUOTA ANTERIORE 21	FLAP FRONT WHEEL 21
12	70050	1		CERCHIO ANT 21x1.60 TAKASAGO BLU	FRONT RIM 1.60x21 Takasago
13	70030.1	1		FERMA COPERTURA RUOTA ANTER. 1.60	STOPPER 1.60
14	49640	1		DADO M 8 FLANGIATO CHIAVE 12	NUT 8mm, FLANGE
15	70246	36		RAGGIO R.ANT.4.0/3.1/4.0 X 230	SPOKE FR.WHEEL 4/3.1/4 X 230
16	70062	36		NIPPLO ACCIAIO 4	SPOKE NIPPLE 4 mm
17	70315	1		MOZZO ANT VMX MA50/KYB EN/MX R4 NUDO	
18	69260	1		DISCO FRENO ANT.2015 270x70,5	BRAKE, FRONT DISK 15->
19	49370	6		VITE TE F/R 6X12	BOLT 6X12
20	70188	1		MOZZO ANT MA50/KYB EN/MX R4 CPL	FRONT HUB MARZ. 2010 --> ASSY



2T125EN25  
2T 125 ES EN

RADIATORI  
RADIATORS

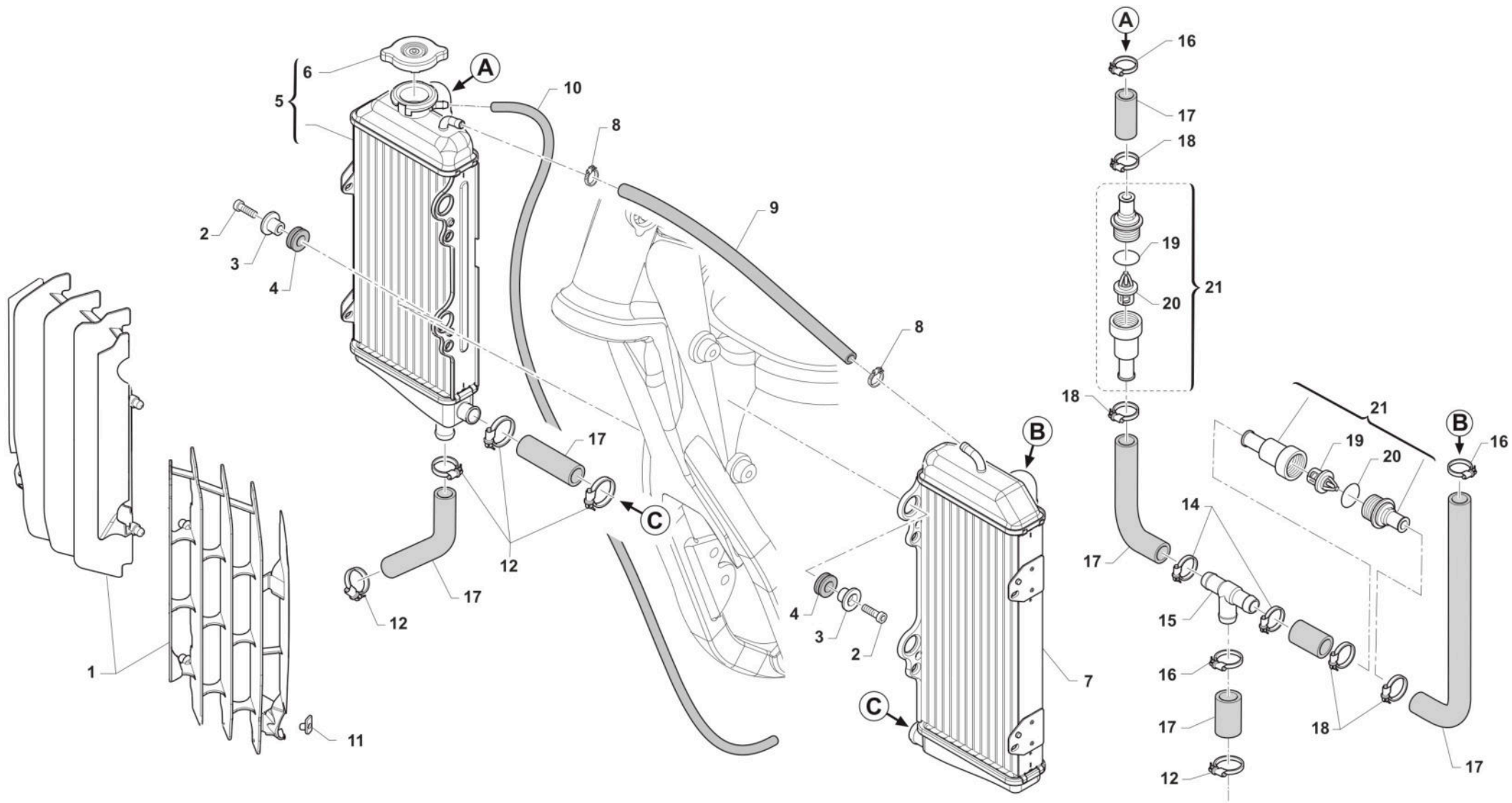

TM 0619.02



2T125EN25  
2T 125 ES EN

RADIATORI  
RADIATORS

5

Pos.	Codice	Q.tà	Note	Descrizione	Description
1	23108	1		KIT PROTEZ. RAD. 2T 125 ES MY25 CPL NERO	
2	49482	4		VITE TCEI 6X14 UNI 5931 Brun	BOLT TCEI 6X14
3	26064	4		BOCCOLA RADIATORE MY 02 / 06 ->	BUSH, RADIATOR M.02/06
4	21102	4		GOMMINO ANTIV.RADIAT.SILENZ. MY 94->	RUBBER, GROMMET RADIATOR and SILENC.
5	23102	1		RADIATORE 2T 125 ES DX MY 2025	
6	23062	1		TAPPO RADIATORE 1,8 BASSO(PER RADIATORE 23065)	RADIATOR CAP 1,8
7	23101	1		RADIATORE 2T 125 ES SX MY 2025	
8	51001	2		FASCETTA 07/11 mm	CLAMP 07/11 mm
9	67422	1		TUBO HYDRO' ECO 5 X 12	
10	67170	1		TUBO COPOLAN GRIGIO 5x9 mm	HOSE, COPOLAN GREY 5x9 mm
11	49801	2		PRESTOLA RADIATORE M6 70117G	RANGE CHANGE MET.NUT M6 70117G
12	51102	5		FASCETTA A COLLARE DIAM.30 ZN	
13	51036	2		FASCETTA A COLLARE DIAM.24 ZN	CLIP, WATER HOSE, d.24 ZN
14	F51115	2		FASCETTA OETIKER 25.6	
15	21147	1		RACCORDO A Y RADIATORI 125 2T	
16	51109	1		FASCETTA OETIKER 31,6	
17	21088	1		KIT TUBI ACQUA 125 ES 2025	
18	F51114	4		FASCETTA OETIKER 27.1	
19	12095	2		O RING TERMOSTATO 2 T	O-RING
20	23069	2		VALVOLA TERMOSTATO 48 GRADI 2019->	THERMOSTAT
21	23107.48	2		TERMOSTATO (PLASTICA) MOTO 48° CON BYPASS	

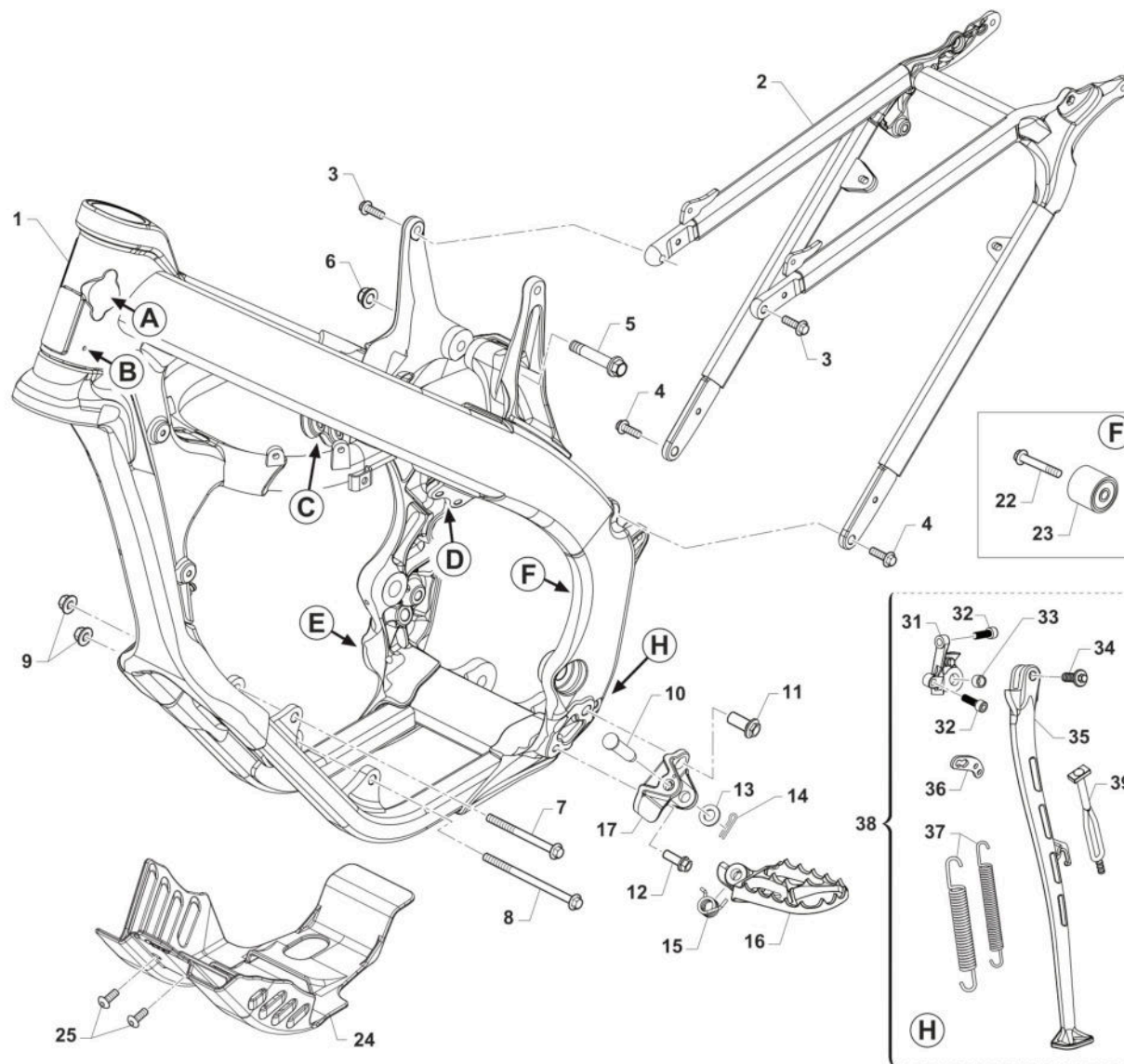
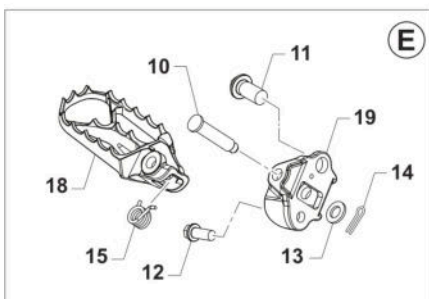
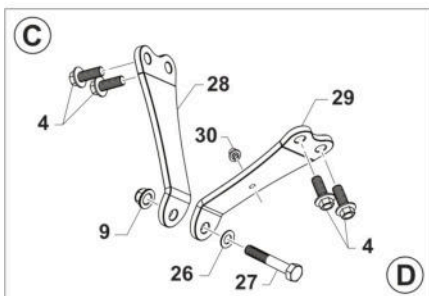
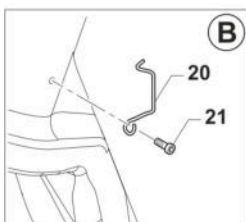
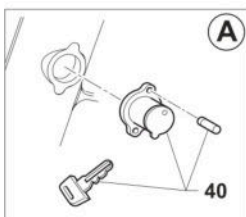

TM 0624.04





2T125EN25  
2T 125 ES EN

TELAIO  
FRAME

7

Pos.	Codice	Q.tà	Note	Descrizione	Description
1	73242	1		TELAIO EN 125 2T MY25PER MOTORE 125 2T 2025	
2	73160	1		CODINO TELAIO 2T MY22	
3	49364	2		VITE TE F/R 8X25 Ch.10	BOLT, EH 8X25 To.10 mm
4	49724	6		VITE TE F/R 8X21	BOLT TE F/R 8x21
5	49792	1		VITE TE F/R 10X54 1.25 T.AL08	BOLT, M10X1.25X54 ALU.FRAME08
6	49681	1		DADO M 10 X 1,25 CH 14 FLANG. AUTOBLOCK	NUT M10x1,25 FLANGED SELF-LOCK
7	49353	1		VITE TE F/R 8X90 1.25 Ch.10	SCREW TE F/R 8X90 1.25 Ch.10
8	49354	1		VITE TE F/R 8X120 1.25 Ch.10	SCREW TE F/R 8X120 1.25 T.10
9	49680	3		DADO M 8 X 1,25 CH 12 FLANG. AUTOBLOCK	NUT, M 8X1,25 FLANG. SB
10	73161	2		PERNO PEDANE MY2022	
11	49382	2		VITE ESAG.FLANG.M12X25 T.A.	BOLT 12 X 25 FLANGE
12	49383	2		VITE ESAG.FLANG.M8X1.25X20 T.A	BOLT 8 X 20 FLANGE
13	49612	2		RONDELLA ACCIAIO 10	STEEL WASHER 10
14	73036	2		COPIGLIA PEDANA M. 92/01	COTTER PIN FOOTPEG 92/01
15	F16481	2		MOLLA RITORNO PEDANA MY2022	
16	F73507	1		PEDANA SINISTRA MY2022	
17	F73509	1		SUPPORTO PEDANA SINISTRA MY2022	
18	F73506	1		PEDANA DESTRA MY2022	
19	F73508	1		SUPPORTO PEDANA DESTRA MY2022	
20	16021	1		MOLLA PASSAGGIO CAVI MOTO (SX)	GROMMET BIKES LF
21	49597	1		VITE TBCEI 4 x 8 UNI 7380	BOLT TBCE 4 x 8
22	49367	1		VITE TE F/R 8X45 Ch.10	BOLT 8X45 T.10mm
23	67088	1		ROTELLA CATENA M. 90/07	CHAIN ROLLER M.90/07
24	50276	1		PARAMOTORE 125 - 144 2T MY2025	GUARD, ENGINE, 2S 125 ES
25	F49861	2		VITE PARACOPPA E.I. M6X16 FL.	BOLT, GUARD ENGINE 6X16
26	49611	1		RONDELLA ACCIAIO 8	WASHER STEEL 8mm
27	49445	1		VITE TE 8X50 UNI 5737	BOLT EH 8X50



2T125EN25  
2T 125 ES EN

TELAIO  
FRAME

7

Pos.	Codice	Q.tà	Note	Descrizione	Description
28	26276	1		PIASTRINO DESTRO FISSAGGIO CILINDRO MOTORE 125 2T AL TELAIO	BRACKET, CYL HANGER, RH SIDE
29	26277	1		PIASTRINO SINISTRO FISSAGGIO CILINDRO MOTORE 125 2T AL TELAIO	BRACKET, CYL HANGER, LH SIDE
30	51097	1		FASCETTA 148x3.6 PER FISSAGGI SU TELAI 150-55850	
31	F73511	1		SUPPORTO CAVALLETTO MY 2022->	
32	49501	2		VITE TCEI 8X25 UNI 5931	BOLT TCEI 8X25
33	F26429	1		BOCCOLA CAVALLETTO M.2008->	BUSH, SIDE STAND MOD. 08/->
34	F49062	1		VITE FISSAGGIO ASTA CAVALLETTO MY 2022	
35	F73512	1		ASTA CAVALLETTO EN MY 2022	
36	F73450	1		PIASTRINO ATT.MOLLA CAVALL.08	BRACKET, SIDE STAND SPRING 08
37	16034.21	1		MOLLA CAVALLETTO LAT. INT+EST EN/SMR 08/->	SPRINGS SIDE STAND EN/SMR MY 08->
38	F73513	1		CAVALLETTO COMPLETO EN MY 2022	
39	21077	1		ELASTICO FISS. CAVALLETTO ENDURO M20->	
40	50512	1		KIT BLOCCASTERZO 08 COMPLETO SEDE+BLOCCHETTO +CHIAVE+VITI	STEERING LOCK M.08-> ASSY



2T125EN25  
2T 125 ES EN

# PLASTICHE E SELLA PLASTIC AND SEAT

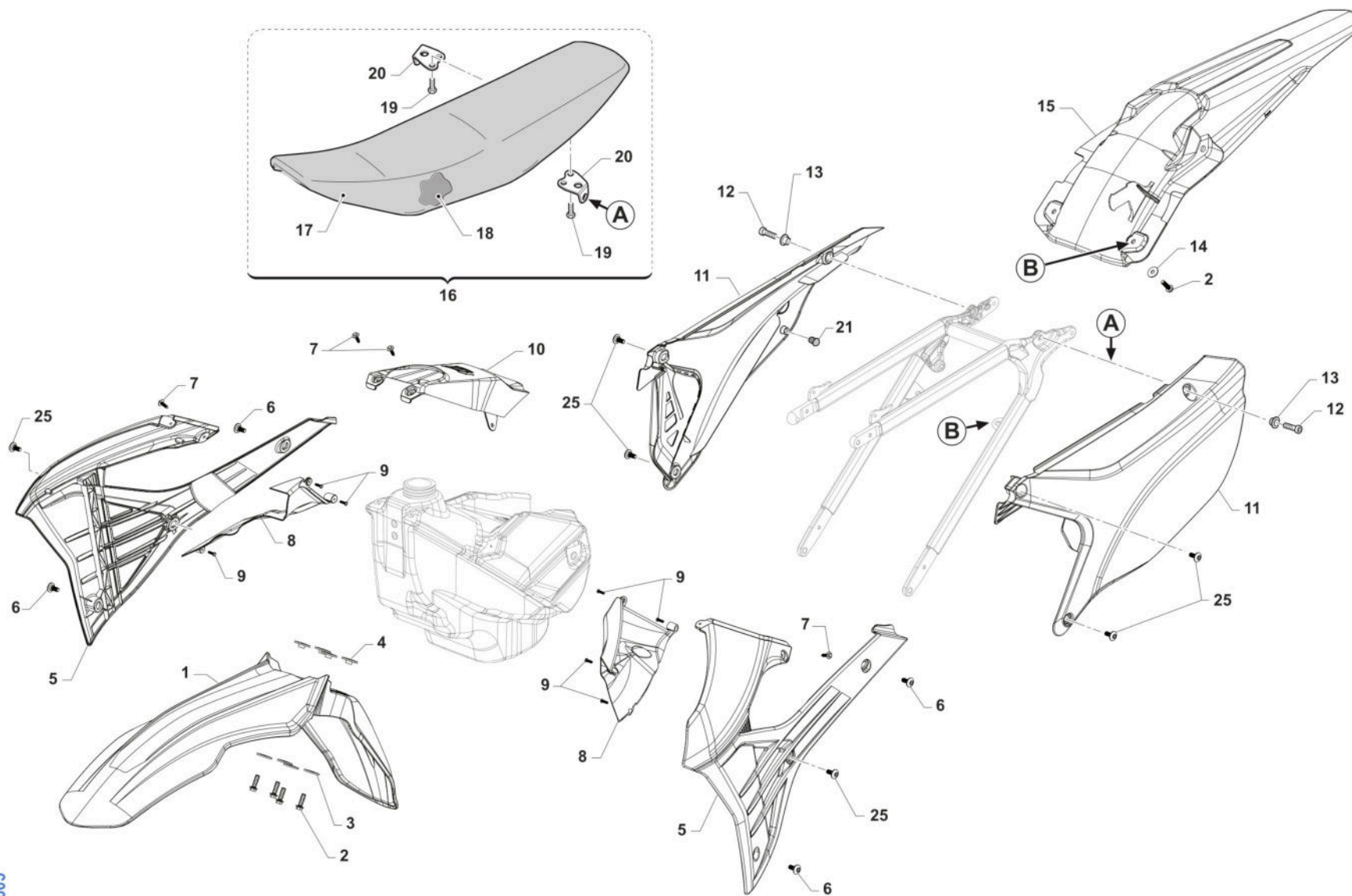

TM0605



2T125EN25  
2T 125 ES EN

PLASTICHE E SELLA  
PLASTIC AND SEAT

8

Pos.	Codice	Q.tà	Note	Descrizione	Description
1	67453	1		PARAFANGO ANTERIORE MY25 QUANTUM	
2	49356	6		VITE TE F/R 6X20 Ch.8	BOLT 6X20 T.8
3	26084	4		RONDELLA PARAF ANT. 24x2 M.08	WASHER, FRONT FENDER 24 X 2
4	26132	4		BOCCOLA PARAF. ANT. M12	BUSH, FRONT MUDGUARD M.12->
5	67470	1		SET CONV. ARIA 2T/4T MY25 QUANTUM	
6	49574	4		VITE TBCE 6 x 12 PLASTICHE	BOLT TBCE 6x12
7	49192	4		VITE TE COL.LARG.TL107 A 4X16 Chrm SERB.PL. MY22	
8	67271.22	1		SET CONVOGL. INTERNI 2T / 4T MY22->	
9	49984	7		VITE TCBL 3.0 X 12 FL. PLASTICA	BOLT
10	67461	1		COVER SERBATOIO 2T MY25 QUANTUM	
11	67472	1		SET LATER. P.NUM. 2T MY25 QUANTUM	
12	49484	2		VITE TCEI 6X20	BOLT TCEI 6X20
13	26059	2		BOCCOLA FISS.SELLA & LAT.03/->	COLLAR, SEAT/SIDE PANEL 03/->
14	49117	2		RONDELLA 18X6.5X2 X RADIAT.08	WASHER 18X6.5X2 RADIATOR 08
15	67457	1		PARAFANGO POSTERIORE 2T/4T MY25 QUANTUM	
16	67469	1		SELLA M.2025 2T/4T CPL QUANTUMTERMOSALDATA	SEAT 2S/4S STANDARD MY 2025 QUANTUM
17	67477	1		COPERTINA SELLA M.2025 2T/4T QUANTUMTERMOSALDATA	
18	67361	1		SPUGNA SELLA CROSS/ENDURO MOD.2022 2T/4T X 67363	
19	49435	4		VITE TE 5X12	SCREW TE 5X12
20	73047	2		PIASTRINO AL ATT.SELLA POSTER.	PLATE AI REAR SEAT HOLDER
21	21141	2		GOMMINO DIST.FIANC/SCARICO M22	
25	490010	6		VITE TBCE 6 x 9 PLASTICHE	



2T125EN25  
2T 125 ES EN

# CASSA FILTRO AIRBOX

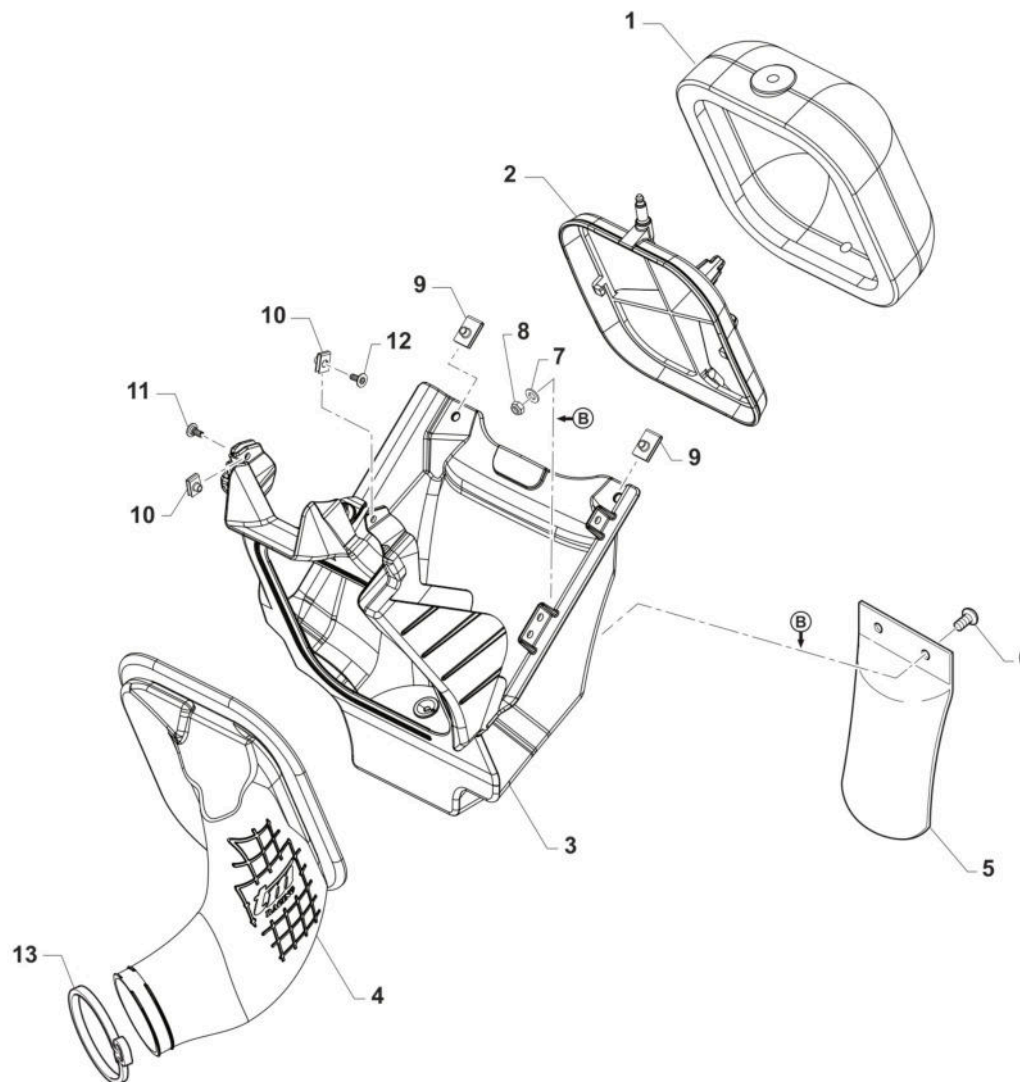

TM 0628.01



2T125EN25  
2T 125 ES EN

CASSA FILTRO  
AIRBOX

9

Pos.	Codice	Q.tà	Note	Descrizione	Description
1	66070	1		FILTRO ARIA 2T MY22 PACKED	
2	66068	1		GABBIA PER FILTRO M22->	CAGE, AIR FILTER MY22->
3	67352	1		CASSA FILTRO 2T CARBUR. CPL MY2022	AIR FILTER BOX ASSY TS CARB. M.22->
4	67412	1		CUFFIA CASSA FILTRO 125 2T ES MY25 CARB.GRIGIO senza piastrino	AIRBOOT 2S 125 ES CARBURETTOR
5	67104	1		PROTEZIONE MONO MOD. 92/->	GUARD, SHOCK ABSOVER M. 92/->
6	490007	2		VITE TBCEI 5 x 12 7380 FLANGE 10.9	BOLT TBCEI 5 x 12 7380 FLANGE
7	49602	2		RONDELLA 5 x 15 x 1,2	WASHER 5x15
8	49633	2		DADO M 5 BASSO AUTOBLOCCANTE	NUT 5mm, LOW SELF-LOCKING
9	49199	2		PRESTOLA M6 C/COLLARINO E ALETTA	U NUT M6
10	51096	2		PRESTOLA M 5 10 X 15	U NUT M5 10x15
11	49753	1		VITE 10.9 TBCEI 5 x 16 UNI 7380	
12	49890	1		VITE TBCEI 5 x 14 UNI 7380 10.9	SCREW TBCE 5X14
13	51104	1		FASCETTA STRINGITUBO DIAMETRO 50-70 LARGHEZZA 9	



2T125EN25  
2T 125 ES EN

# FORCELLONE SWINGARM

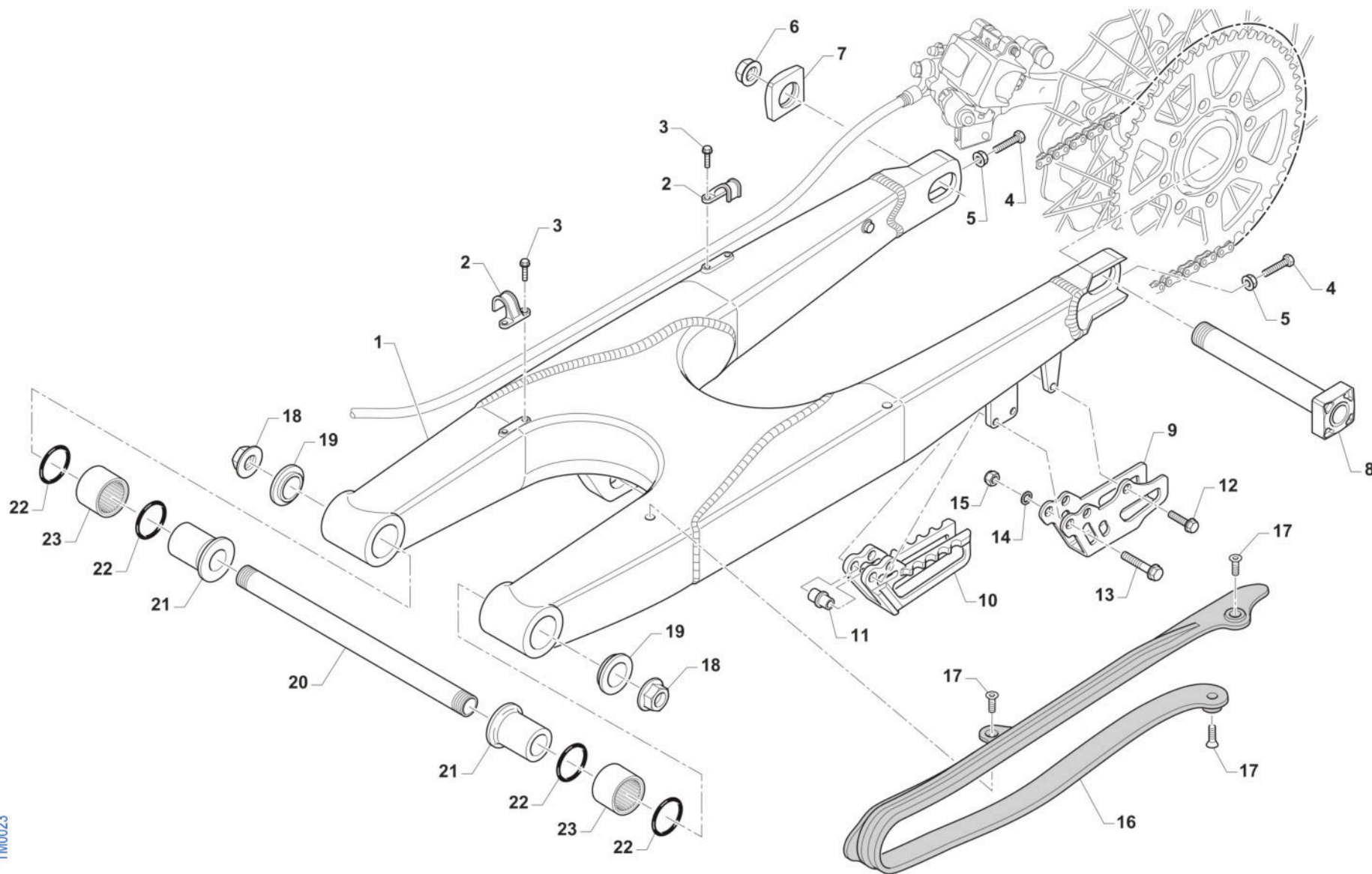

TM0023



2T125EN25  
2T 125 ES EN

FORCELLONE  
SWINGARM

10

Pos.	Codice	Q.tà	Note	Descrizione	Description
1	73099.15	1		FORCELLONE MOTO 2T/4T MY 15/22	SWINGARM 2S MY 15
2	67054	2		FERMA TUBO FRENO POST. M.97/->	RETAIN CLAMP BRAKE HOSE 97/->
3	49794	4		VITE AUTOFOR. 4.8X16 7504	BOLT, 4,8 X 16 7504
4	F49976	2		VITE TE 8X45 ES.10 FORCELLONE	SCREW TE 8X45 SWINGARM
5	49640	2		DADO M 8 FLANGIATO CHIAVE 12	NUT 8mm, FLANGE
6	49123	1		DADO PERNO RUOTA POST. M.2015	NUT, REAR WHEEL AXLE 15 ->
7	70140.15	1		TENDICATENA 2015 SENZA FILETTO	ADJ BLOCK, CHAIN 15-THREADLESS
8	74055.15	1		PERNO RUOTA POSTERIORE M.15->	AXLE, REAR WHEEL M.15->
9	73130	1		PASSACATENA ALLUM. MOD. 11/->	PLATE, CHAIN GUIDE M. 11/->
10	67102.10	1		PASSACATENA NYLON MOD.2011	GUIDE, CHAIN M. 11/->
11	26092	1		BOCCOLA PASSACATENA M.11->	BUSH, CHAINGUIDE M11->
12	49370	1		VITE TE F/R 6X12	BOLT 6X12
13	49362	2		VITE TE F/R 6X50 Ch.8	BOLT 6X50 T.8
14	49603	2		RONDELLA M 6,4 X 12 X 1,6	WASHER 6x12
15	49638	2		DADO M 6 ALTO AUTOBLOCCANTE	NUT 6mm, HIGHT SELF-LOCKING
16	67099.15	1		PROTEZIONE FORCELLONE M.2015	SWINGHARM PROTECTION M.2015
17	49396	3		VITE TSEI 5X10	BOLT TSEI 5X10
18	49095	2		DADO 16 FORCELLONE MOTO 95/10	NUT, SWINGARM AXLE M. 95/05
19	73115	2		COPERCHIO BOCCOLA FORC. M08->	COLLAR, SWINGARM M.08
20	74056	1		PERNO FORCELLONE MOD. 08/->	AXLE SWINGARM M. 08->
21	73112	2		BOCCOLA FORC. 08/-> F16(30X49)	BUSH, SWINGARM 08-> H.16 30X49
22	12102	4		O RING LEVERAGGIO & FORCELLONE	O-RING, LINKAGE & SWINGARM
23	19043	2		ASTUCCIO A RULLI HK 20/30	NEEDLE CAGE HK 20/30





2T125EN25  
2T 125 ES EN

LEVERAGGI EN +1  
LINKAGE EN +1

EN +1

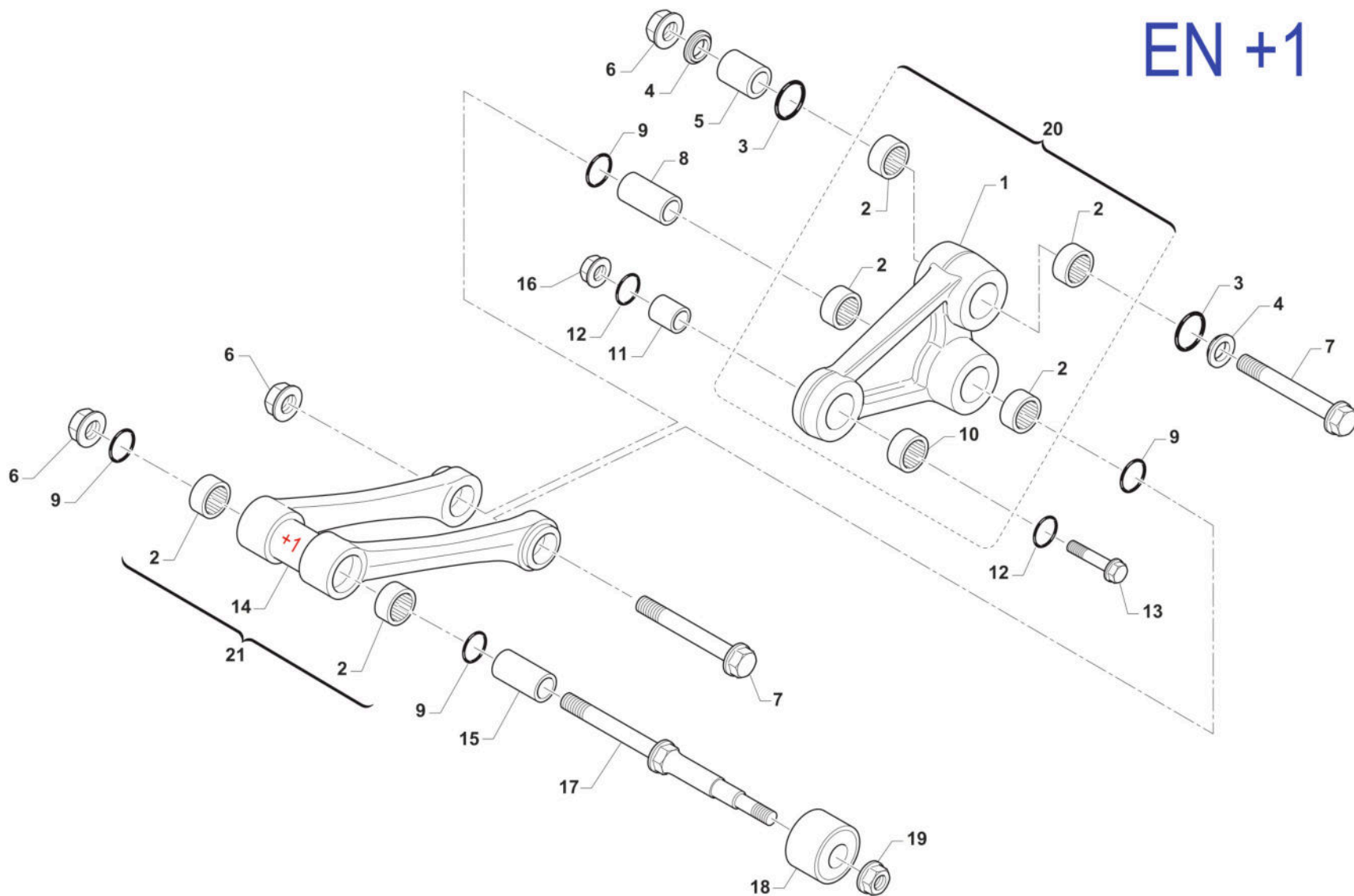

TM 0645.01



2T125EN25  
2T 125 ES EN

LEVERAGGI EN +1  
LINKAGE EN +1

11

Pos.	Codice	Q.tà	Note	Descrizione	Description
1	73145	1		TRIANGOLO SOSP. MY 15/23 NUDO	ARM
2	19106	6		GABBIA RULLINI DL 2016 KYU	BUSH NEEDLE CAGE 26 X 20 H16
3	12010	2		O RING ORM 0240-30 TRIANG.05/6	O-RING, LINKAGE 05/6 ORM 0240-30
4	73075	2		COPERCHIO BOCCOLA TRIANG '05	COVER, BUSH
5	73211	1		BOCCOLA TRIANGOLO LEVER.05/->	BUSH, ARM RELAY 12X20X38
6	49194	3		DADO M12X1.25 FLANG. CH14	
7	49345	2		VITE TE F/R 12X90 1.25 Ch13	BOLT TE F/R 12X90 1.25 T.13
8	F73416	1		BOCCOLA TRIANG. 20x48F12 05/->	COLLAR, ROD M.04 12x20x48
9	12102	4		O RING LEVERAGGIO & FORCELLONE	O-RING, LINKAGE & SWINGARM
10	19101	1		GABBIA RULLINI DL 1812 KYU	BUSH NEEDLE CAGE DL 18/12
11	73214	1		BOCCOLA 18 X 20 F.10 TRIANGOLO 07/->	COLLAR, ARM ASSY 10 18X20 M.07
12	F12312	2		O RING FILTRO OLIO P.ASPIRAZ.+LEV.	O-RING, OIL FILTER
13	49347.1	1		VITE TE F/R 10X43 1.25 Ch.13	BOLT TE F/R 10X43 1.25 T.10
14	73168	1		TRAPEZIO SOSP. MY 15/25 +1 NUDO	
15	73204	1		BOCCOLA TRAPEZIO 20 x 74 F.12	BUSHING 20x74x12, ROD SUSP. 05
16	F49874	1		DADO M 10 X 1,25 CH 12 FLANGIATO	NUT FLANGED M 10x1,25 T.12mm
17	49790	1		PERNO SNODO BIELLA/ROT.CAT.M08	PIVOT, LINKAGE/ROLLER 08/->
18	67088.08	1		ROTELLA CATENA M. 08/->	CHAIN ROLLER 08/->
19	49676	1		DADO M 6X1 FLANG. AUTOBL.ACC.	NUT, FLANGED M6 X 1 S.B.
20	73016.15	1		TRIANGOLO SOSP. MY 15/22 CPL	ARM ASSY RELAY M.Y.2015
21	73169	1		TRAPEZIO SOSP. [ + 1 ] MY 15/25 CPL	



2T125EN25  
2T 125 ES EN

RUOTA POSTERIORE 18x1.85  
REAR WHEEL 18x1.85

12

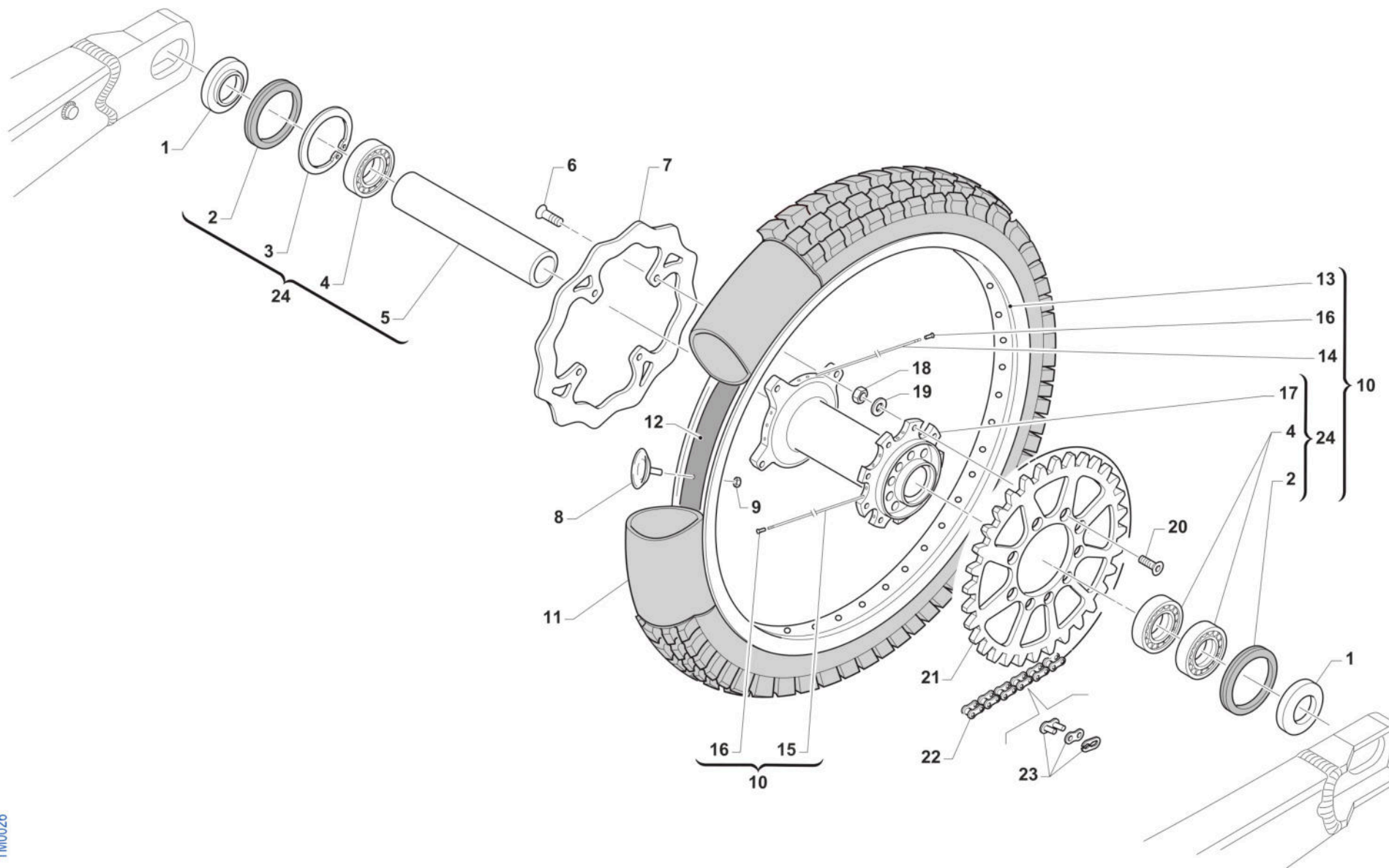

TM0026



2T125EN25  
2T 125 ES EN

RUOTA POSTERIORE 18x1.85  
REAR WHEEL 18x1.85

12

Pos.	Codice	Q.tà	Note	Descrizione	Description
1	70241	2		DISTANZ. RUOTA PST. 2015 DX/SX	COLLAR REAR WHEEL LE.RI. 15->
2	04074	2		PARAPOLVERE RUOTA POST. MOD.15->	DUST SEAL, REAR WHEEL 15 ->
3	49257	1		SEEGER I 43 mm	CIRCLIP D. 43 INTERNAL
4	03071	3		CUSCINETTO RUOTA ANTER. + POSTER.	BUSH, FRONT WHEEL MA50 61905
5	70240	1		DIST.INT.MOZZO RUOTA PST.15 3C 114,2x31 SP2.7	SPACER INT.REAR WHEEL M.15->
6	49336	4		VITE TE/FLANG. 6X16 ACC. 10.9	BOLT 6X16 FLANGED STEEL 10.9
7	69261	1		DISCO FRENO PST.2015 240x114 DF840W	DISC, REAR BRAKE 15-> 240X114
8	70027	1		FERMA COPERTURA POST. 1.85	STOPPER 1,85, TUBE
9	49640	1		DADO M 8 FLANGIATO CHIAVE 12	NUT 8mm, FLANGE
10	70145.15	1		CERCHIO PST. CPL 18X1.85 2015	REAR RIM ASSY 18x1.85 MY 15->
11	80151	1		CAMERA ARIA POSTERIORE 18	TUBE, TYRE 18
12	70033	1		FLAP RUOTA POSTERIORE 18	FLAP REAR WHEEL 18
13	70052	1		CERCHIO POST 18x1.85 TAKASAGO BLU	REAR RIM 1.85x18 Takasago
14	70270	18		RAGGIO R.PST.4.0/3.3/4.0 X 192	SPOKE R.WHEEL 4.0/3.3/4.0 X192
15	70271	18		RAGGIO R.PST.4.0/3.3/4.0 X 199	SPOKE R.WHEEL 4.0/3.3/4.0 X199
16	70062	36		NIPPLO ACCIAIO 4	SPOKE NIPPLE 4 mm
17	70316	1		MOZZO POST NUDO VMX MY2021	
18	49643	9		DADO M 8 BASSO AUTOBLOCCANTE	NUT 8mm, LOW SELF-LOCKING
19	49611	9		RONDELLA ACCIAIO 8	WASHER STEEL 8mm
20	49421	9		VITE TSEI 8X25	BOLT TSEI 8X25
21	70103.48	1		CORONA CATENA Z 48 M. 86/->	SPROCKET 48T, REAR, M.86/->
21	70103.49	1		CORONA CATENA Z 49 M. 86/->	SPROCKET 49T, REAR, M.86/->
21	70103.50	1		CORONA CATENA Z 50 M. 86/->	SPROCKET 50T, REAR, M.86/->
21	70103.51	1		CORONA CATENA Z 51 M. 86/->	SPROCKET 51T, REAR, M.86/->
21	70103.52	1		CORONA CATENA Z 52 M. 86/->	SPROCKET 52T, REAR, M.86/->
21	70103.53	1		CORONA CATENA Z 53 M. 86/->	SPROCKET 53T, REAR, M.86/->
21	70290.50	1		CORONA CATENA Z 50 M. 86/-> ZF	SPROCKET 50T MY 86-> ZF
21	70290.51	1		CORONA CATENA Z 51 M. 86/-> ZF	SPROCKET 51T MY 86-> ZF



2T125EN25  
2T 125 ES EN

RUOTA POSTERIORE 18x1.85  
REAR WHEEL 18x1.85

12

Pos.	Codice	Q.tà	Note	Descrizione	Description
21	70290.52	1		CORONA CATENA Z 52 M. 86/-> ZF	SPROCKET 52T MY 86-> ZF
21	70291.48	1		CORONA BLU/NERA ALLU/ACCIAIO Z48 ZF	SPROCKET BLUE/BLACK ALU/STEEL 48 T ZF
21	70291.49	1		CORONA BLU/NERA ALLU/ACCIAIO Z49 ZF	SPROCKET BLUE/BLACK ALU/STEEL 49 T ZF
21	70291.50	1		CORONA BLU/NERA ALLU/ACCIAIO Z50 ZF	SPROCKET BLUE/BLACK ALU/STEEL Z50 ZF
21	70291.51	1		CORONA BLU/NERA ALLU/ACCIAIO Z51 ZF	SPROCKET BLUE/BLACK ALU/STEEL 51T ZF
21	70291.52	1		CORONA BLU/NERA ALLU/ACCIAIO Z52 ZF	SPROCKET BLUE/BLACK ALU/STEEL 52 T ZF
22	70100	1		CATENA REGINA 114MG	REGINA CHAIN 135 RX 114
23	70098	1		GIUNTO CATENA REGINA 135 RX3	CHAIN LINK 135 RX3
24	70119.15	1		MOZZO POSTERIORE 2015 CPL	REAR HUB 2015 -> ASSY



2T125EN25  
2T 125 ES EN

FRENO POSTERIORE  
REAR BRAKE

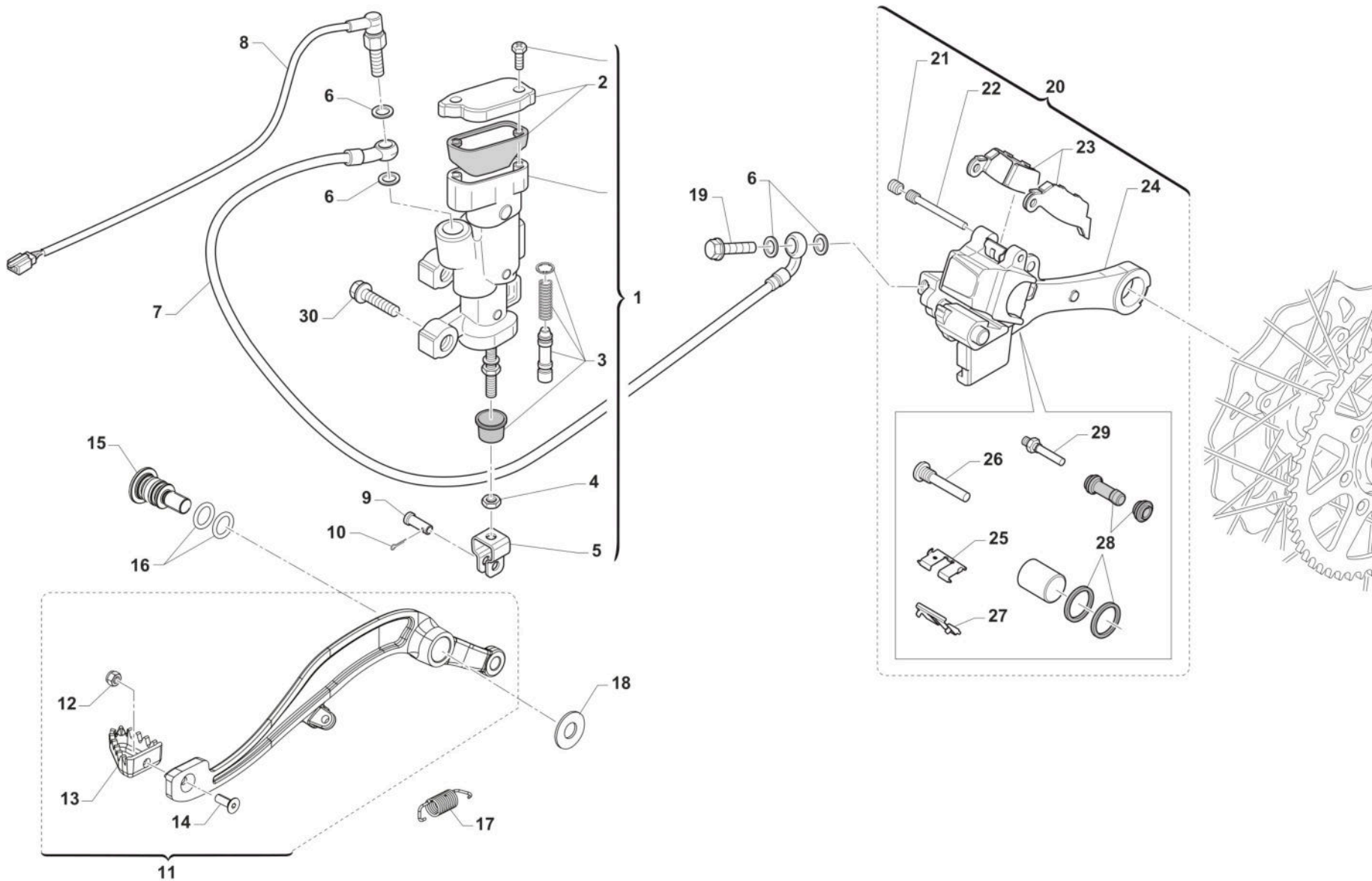

TM 0615



2T125EN25  
2T 125 ES EN

FRENO POSTERIORE  
REAR BRAKE

13

Pos.	Codice	Q.tà	Note	Descrizione	Description
1	69345	1		POMPA FRENO POST 05/-> INTEGR (OBLO' 2020)	
2	69321	1		KIT TAPPO/GUARN. POMPA PST NIS	CAP AND RUBBER
3	69084.05	1		KIT REV. PIST.POMPA POST.05/->	KIT, REV. REAR MASTER CYL.05->
4	49636	1		DADO M 6	NUT M6
5	69125	1		FORCHETTINA POMPA FRENO POS.05	FORK, REAR BRAKE 05
6	69034	4		RONDELLA X BULLONE FREN B22001	WASHER B22001, BRAKE HOSE
7	69379	1		TUBO FRENO POSTERIORE 2T/4T M.2022	
8	68061	1		INTERRUT. IDR. STOP NISSIN 90 GRADI	SWITCH,IDR.NISSIN 10x1.25 1/12
9	69012.05	1		PERNO SNODO FRENO POST. MY 05->	PIN REAR BRAKE MASTER CYL. MY 05->
10	68997	1		COPIGLIA PEDALE FRENO	COTTER PIN BRAKE PEDAL
11	69000.22	1		PEDALE F.POST 2T 125/144 + 4T 250/300 MY 22	BRAKE PEDAL, REAR 2S 125/144 + 4S 250/300 MY 22
12	49629	1		DADO M 5 ALTO AUTOBLOCCANTE	NUT 5mm, HIGHT SELF-LOCKING
13	69002.99	1		PARTE ANT.PED.FRENO POST.99/->	PIT, RR BRAKE PEDAL 99/->
14	49400	1		VITE TSEI 5X14	BOLT TSEI 5x14
15	F49063	1		VITE FISSAGGIO PEDALE FRENO MY22	
16	12110	2		O RING PEDALE FRENO POST. MY22->	
17	F16482	1		MOLLA PEDALE FRENO MY 22	
18	F48403	1		RONDELLA PEDALE FRENO MY22	
19	69094	1		BULLONE 10X1.25 T.FRENO NISSIN 03	BOLT,10X1,25 BRAKE HOSE NISSIN
20	69185.15	1		PINZA FRENO POST. 15-> NISSIN	BRAKE CALIPER, REAR, M. 15/->
21	69087	1		GRANO PERNO 69088 NISSIN 01/11	SCREW PLUG FOR BRAKE PIN 01/07
22	69088	1		PERNO PAST. POST NISSIN 01/11	PIN, RR BRAKE NISSIN M. 01/->
23	69096.05	1		PASTIGLIE FRENO POST. M.05-> NISSIN	PAD ASSY, RR BRAKE NISSIN MY 05->
24	69285.15	1		SUPPORTO PINZA D. 25 FRENO POST NISSIN 15/->	HOLDER, REAR BRAKE CALIPER
25	69309	1		PIASTR.FERMA P.NISSIN RETAINER	RETAINER BRAKE PADS NISSIN
26	69257	1		PERNO/VITE PINZA POST.01/->	PIN, RR BRAKE CALIPER 01-> NI.
27	69086	1		LAMIERINO PINZA POST NIS 01/->	PLATE, REAR BRAKE CALIPER 01->
28	69258	1		KIT REV.GOMM. PINZA PST 05/->	REAR BRAKE CALIPER RUBBER REVIEW 05/->



2T125EN25  
2T 125 ES EN

FRENO POSTERIORE  
REAR BRAKE

13

Pos.	Codice	Q.tà	Note	Descrizione	Description
29	69232	1		PERNO X PINZA FRENO POST.05/12	PIN, RR BRAKE CALIPER 05/12
30	49574	2		VITE TBCE 6 x 12 PLASTICHE	BOLT TBCE 6x12





2T125EN25  
2T 125 ES EN

SCARICO  
EXHAUST SYSTEM

14

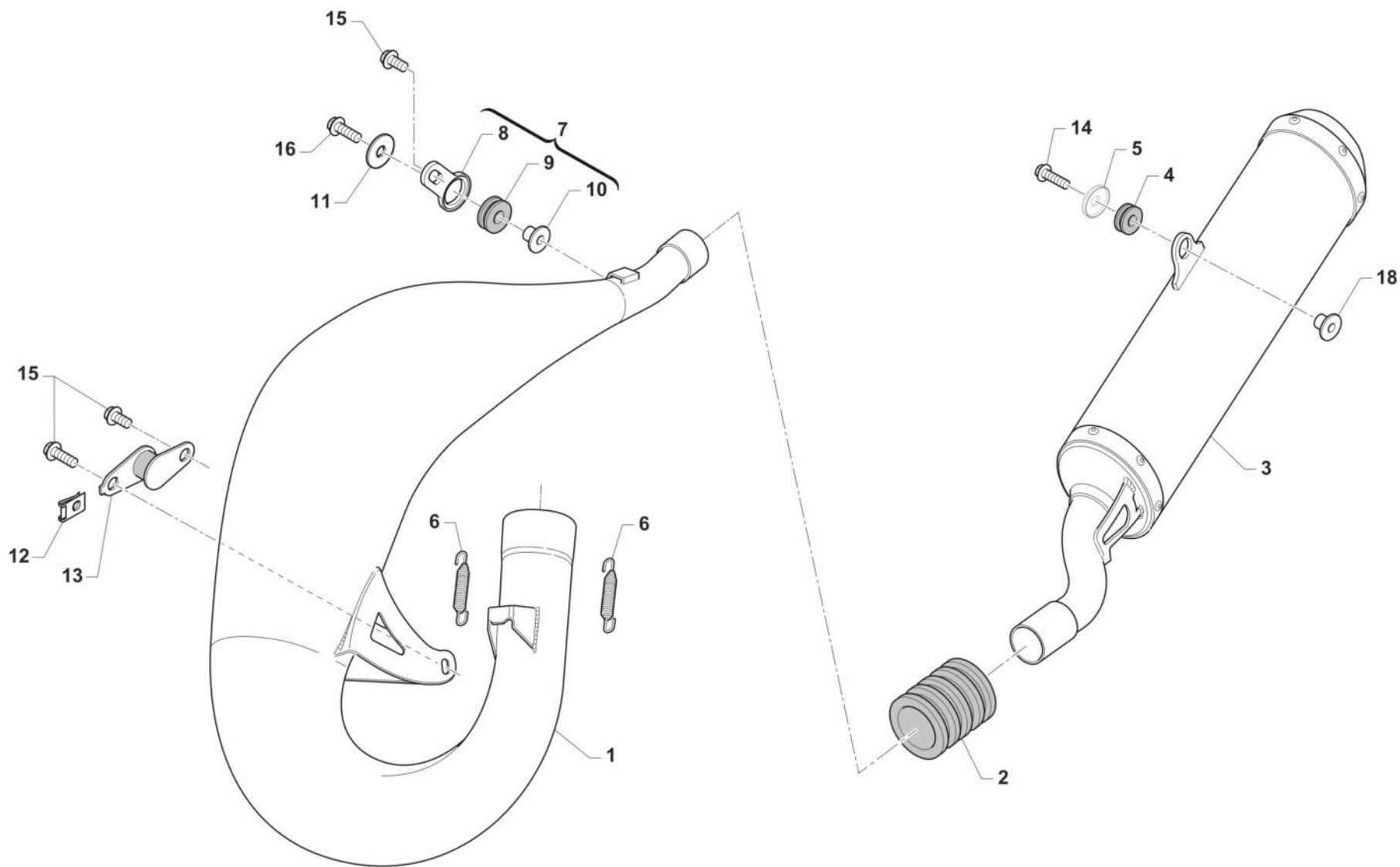

TM 0612.01



2T125EN25  
2T 125 ES EN

SCARICO  
EXHAUST SYSTEM

14

Pos.	Codice	Q.tà	Note	Descrizione	Description
1	27314	1		MARMITTA 125 END/SMR 2025(USE ONLY FOR RACES)	EXHAUST 2S 125 EN ES MY 25
2	21019	1		MANICOTTO SILENZIATORE SILICONE 97 ->	RUBBER, SILENCER/PIPE 97/->
3	27217	1		SILENZIATORE 125 END / SMR HGS MY22-> D.26	
4	21142	1		GOMMINO SILENZIATORE HGS MY22->	
5	48264	1		DISTANZIALE ESTERNO FISSAGGIO SCARICO	
6	16003.2	2		MOLLA TR.SCARICO BICONICA F.3	SPRING. EXHAUST WIR. 3mm
7	21094	1		SILENT BLOCK 05 PIAST+GOMM+BOC	SILENT BLOCK 05 ASSY PL+RU+BU
8	21093	1		PIASTRINO SILENT BLOCK 05 NUDO	PLATE, SILENT BLOCK 05
9	21102	1		GOMMINO ANTIV.RADIAT.SILENZ. MY 94->	RUBBER, GROMMET RADIATOR and SILENC.
10	26074	1		BOCCOLINA X SILENT-BLOCK 21094	BUSH FOR SILENT-BLOCK COD21094
11	26084	1		RONDELLA PARAF ANT. 24x2 M.08	WASHER, FRONT FENDER 24 X 2
12	49803	1		PRESTOLA SILENT BLOCK MARMITTA	RANGE CHANGE METAL NUT M6
13	21111	1		SILENT BLOCK MARMITTA M.94->	SILENT BLOCK EXHAUST PI.M.94->
14	49898	1		VITE TE F/R 8X30 Ch.10	
15	49355	3		VITE TE F/R 6X16 Ch.8	BOLT 6X16 T.8
16	49356	1		VITE TE F/R 6X20 Ch.8	BOLT 6X20 T.8
18	26196	1		BOCCOLA GOMMINO SILENZ. HGS MY22->	



2T125EN25  
2T 125 ES EN

CABLAGGI  
EXHAUST

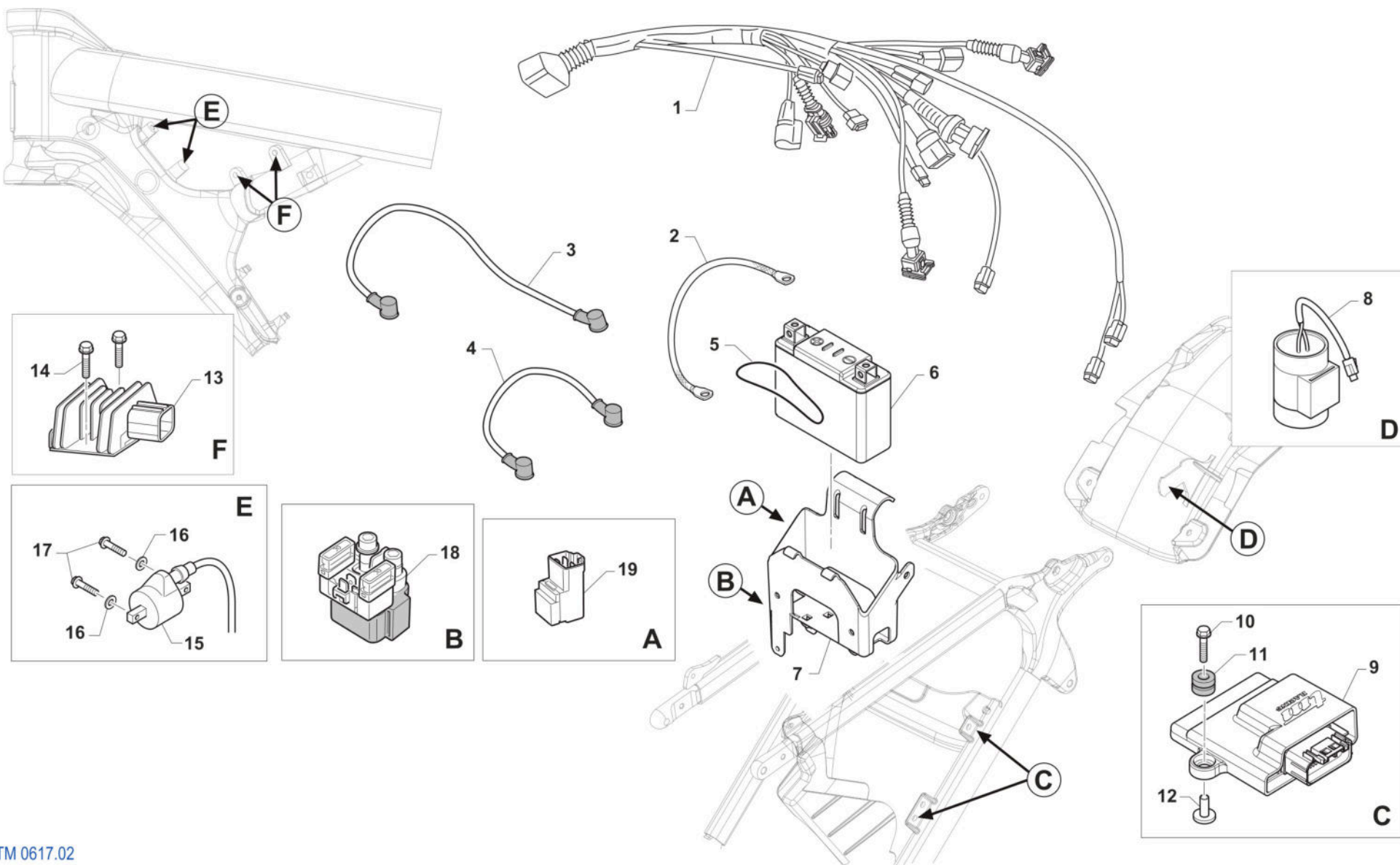

TM 0617.02



2T125EN25  
2T 125 ES EN

CABLAGGI  
EXHAUST

15

Pos.	Codice	Q.tà	Note	Descrizione	Description
1	68325	1		CABLAGGIO 2T 125 MX ES CARB. MY 2025	WIRING, MAIN, 2S 125 MX ES CARB. MY 25
2	50267	1		TRECCIA DI MASSA E.S. MY 22->	
3	68231	1		CAVO 2T 250/300 ES BATTERIA MOD. 2019	BLACK BATTERY CABLE
4	F68213	1		CAVO BATTERIA ROSSO M. 2015	WIRE BATTERY RED M.15->
5	12001	1		O RING TESTATA CR 89/K2/K3/KF	
6	68234	1		BATTERIA ALIANT YLP09X 12V EQ. 8AH	BATTERY LITHIUM ION <100WH YLP09X 12V8AH
7	F68297	1		SUPPORTO BATTERIA	SUPPORT, BATTERY
8	F15557	1		CONDENSATORE SHINDENGEN ADP19	CAPACITOR SHINDENGEN ADP19
9	08127.0	1		CENTRALINA MX/EN 125 2T CARB. 2025	
10	49174	2		VITE TE/FLANG. 5 x 25 UNI 6921	
11	21045	2		GOMMINO C/CHILOM. & CDI 08/11	RUBBER, SPEEDOMETER/CDI 08/13
12	F26498	2		BOCCOLA CENTRALINA INIEZIONE	
13	F15559	1		REGOLATORE KOKUSAN RX4513 ZERO SOSTITUISCE COD. F15476	REGULATOR KOKUSAN RX4513 REPLACE CODE F15476
14	49356	2		VITE TE F/R 6X20 Ch.8	BOLT 6X20 T.8
15	F15458	1		BOBINA KOKUSAN 4T MX PICCOLA	COIL, IGNITION KOK IG5132
16	49603	2		RONDELLA M 6,4 X 12 X 1,6	WASHER 6x12
17	49357	2		VITE TE F/R 6X25 Ch.8	BOLT 6X25 T.8
18	F68102	1		RELAY AVV. ELETTRICO 2 e 4 TEMPI	RELAY, ELECTRIC STARTER
19	F68212	1		RELAY AVV. ELETTRICO PAN. M2015->	RELAY EL. STARTER M.-> 15

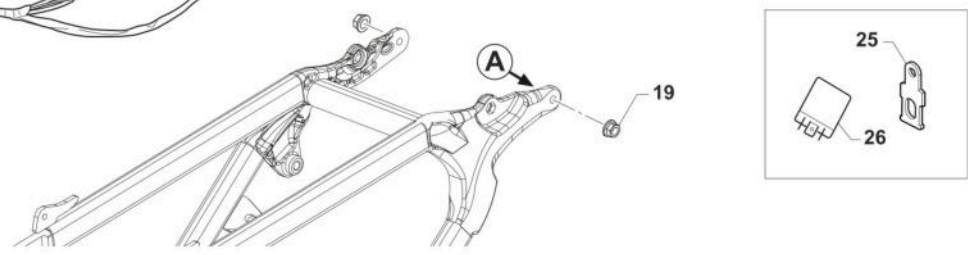
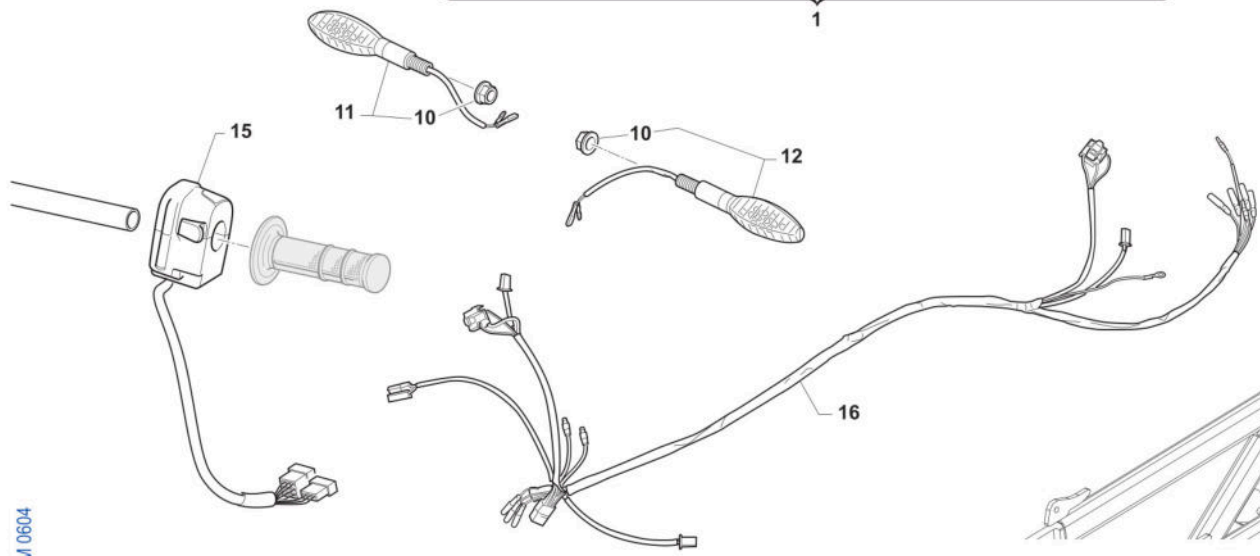
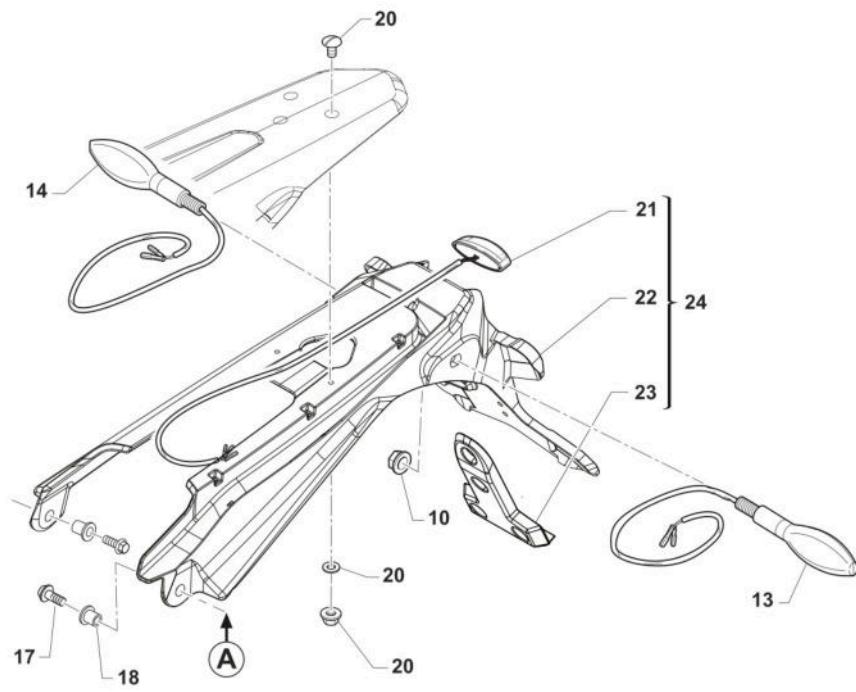
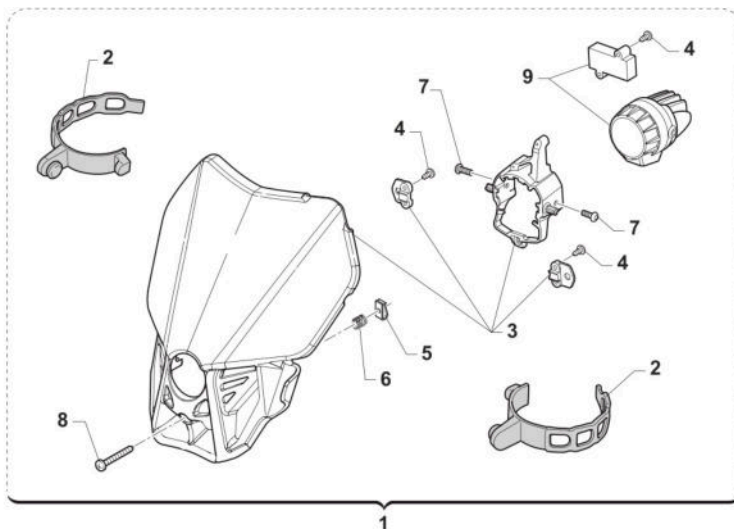

TM 0604



2T125EN25  
2T 125 ES EN

IMPIANTO LUCI  
LIGHTING SYSTEM

16

Pos.	Codice	Q.tà	Note	Descrizione	Description
1	67476	1		PORTAFARO CPL QUANTUM C/FARO LED MY25	
2	67220.7	2		ELASTICO PORTAFARO X 67043.12/20	ELASTIC FOR HEADLIGHT 67043.12 / 20
3	67468	1		PORTAFARO NUDO MY25 QUANTUM (X 67476)	HEADLIGHT MASK (ONLY PLASTIC) QUANTUM MY25
4	49802	5		VITE PARKER 3.5X 13	SCREW PARKER 3,5X13
5	51092	1		PRESTOLA M4 10 X 15	RANGE CHANGE MET.NUT M4 10 X 15
6	16072	1		MOLLA REGOLAZIONE FARO LED 2020 X 67043.20	SPRING
7	49785	2		VITE TBCE 5X 6	BOLT TBCE 5X6
8	49309	1		VITE T.C. 4X20	BOLT TC 4X20
9	68258	1		FANALE P.FARO A LED MY2020	
10	F49962	4		DADO M 10 X 1,25 CH 14 FLANGIATO	NUT, M10 X 1,25 KEY 14
11	68251.1	1		FRECCIA ANTERIORE LED DX	FLASHER LED, FRONT RH
12	68251.2	1		FRECCIA ANTERIORE LED SX	FLASHER LED, FRONT LH
13	68251.4	1		FRECCIA POSTERIORE LED SX	FLASHER LED, REAR LH
14	68251.3	1		FRECCIA POSTERIORE LED DX	FLASHER LED, REAR RH
15	68287	1		DISPOSITIVO DEVIOLUCI SX END. MY22->	
16	68292	1		CABLAGGIO LUCI 2T/4T ENDURO CPL MY2022	
17	49357	2		VITE TE F/R 6X25 Ch.8	BOLT 6X25 T.8
18	26186	2		BOCCOLA FISSAGGIO PARAF/P.TARGA EN/SMR MY22 18x12.8 F.6	
19	49676	2		DADO M 6X1 FLANG. AUTOBL.ACC.	NUT, FLANGED M6 X 1 S.B.
20	49277	1		KIT VITI PORTATARGA MY 2022	
21	67351	1		FANALINO POST. LED KOSO HAWKEYE	
22	F67180	1		PORTATARGA MY2022 NUDO	
23	F67181	1		SUPPORTO CATADIOTTRO MY2022	
24	F67208	1		PORTATARGA MY2022 COMPLETO	
25	F26717	1		SUPPORTO RELE' FRECCIE LED 2020	HOLDER
26	68250	1		CENTRALINA INTERM.FREC. 2019 Lampade led	CDI, FLASHER



2T125EN25  
2T 125 ES EN

CONTA KM + CLACSON  
SPEEDOMETER + HORN

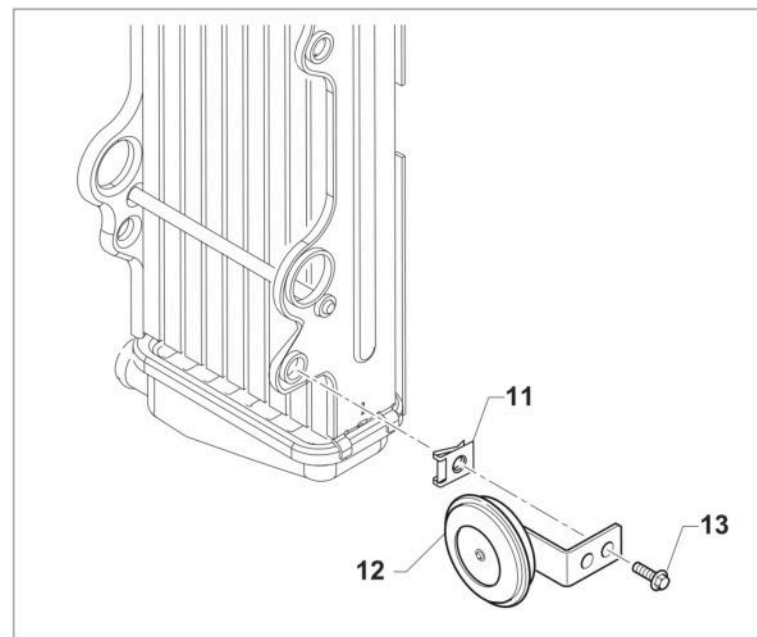
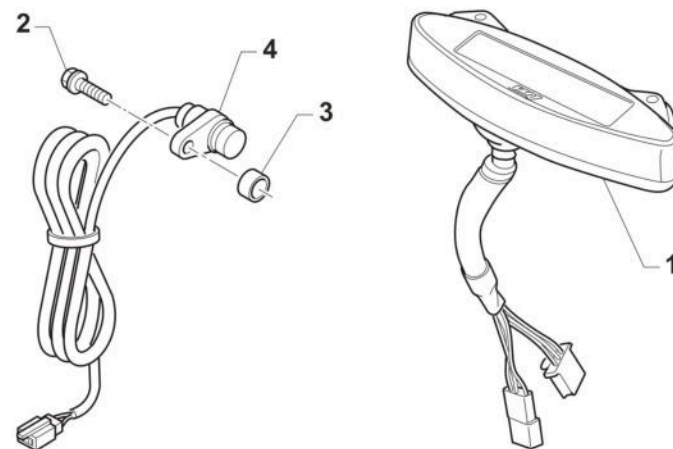
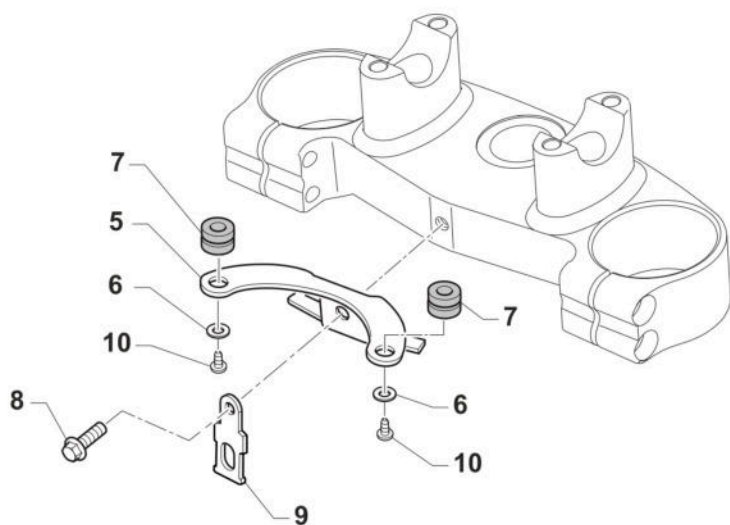

TM0609



2T125EN25  
2T 125 ES EN

CONTA KM + CLACSON  
SPEEDOMETER + HORN

17

Pos.	Codice	Q.tà	Note	Descrizione	Description
1	64134	1		CONTACHILOMETRI DIG. M.22-> SENZA CABL. SENSOR.	
2	49356	1		VITE TE F/R 6X20 Ch.8	BOLT 6X20 T.8
3	26115	1		BOCCOLA SENSORE CKM KOSO 08	BUSH, SENSOR SPEEDOMETER 08
4	64135	1		CABLAGGIO SENSORE C/KM MY22->	
5	F64349	1		SUPPORTO CONTACHILOMETRI EU4	HOLDER, SPEEDOMETER eu 4
6	49982	2		RONDELLA 4x12x1 x CONTA/KM 64130	WASHER
7	21045	2		GOMMINO C/CHILOM. & CDI 08/11	RUBBER, SPEEDOMETER/CDI 08/13
8	49355	1		VITE TE F/R 6X16 Ch.8	BOLT 6X16 T.8
9	F26717	1		SUPPORTO RELE' FRECCHE LED 2020	HOLDER
10	49553	1		VITE TCEI 4X8 5931-912 Brun	BOLT TCEI 4X8
12	F68335	1		CLACSON C/C NO RETTIFICAT. LB	
13	49370	1		VITE TE F/R 6X12	BOLT 6X12





2T125EN25  
2T 125 ES EN

KIT ADESIVI EN

18

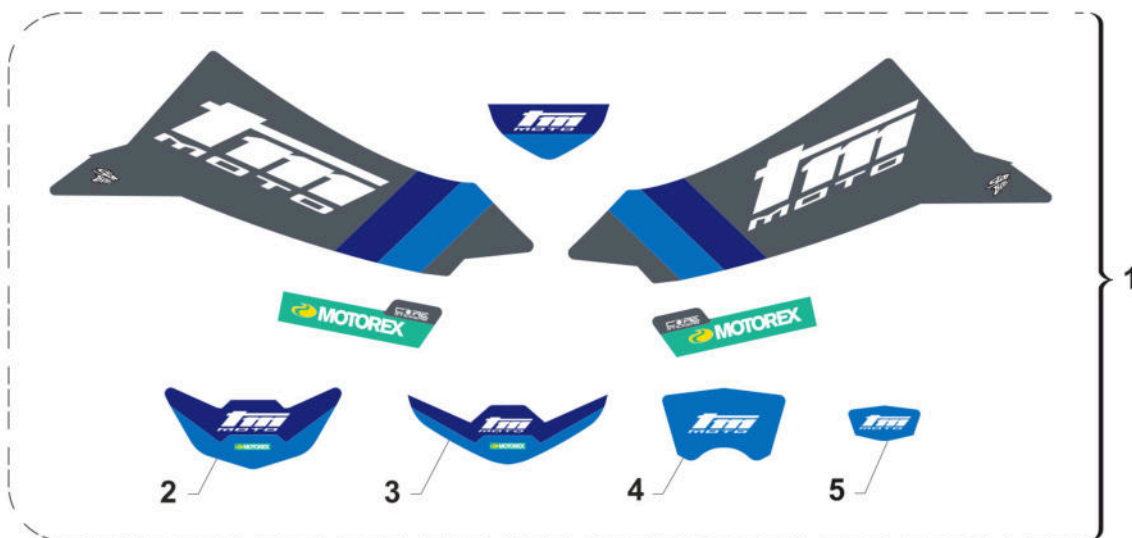

**2S EN**

**4S EN**

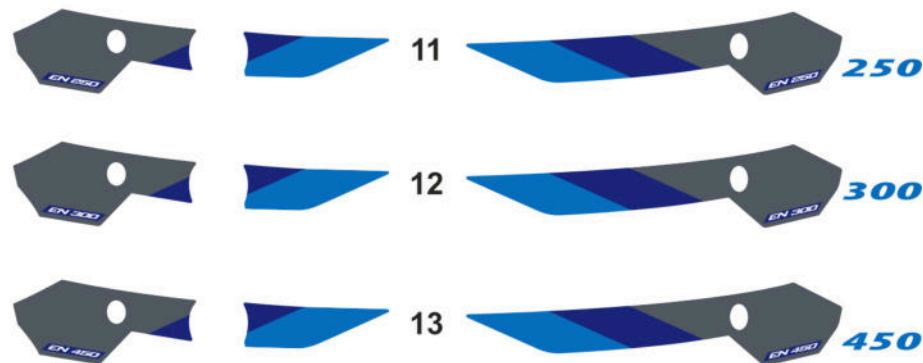
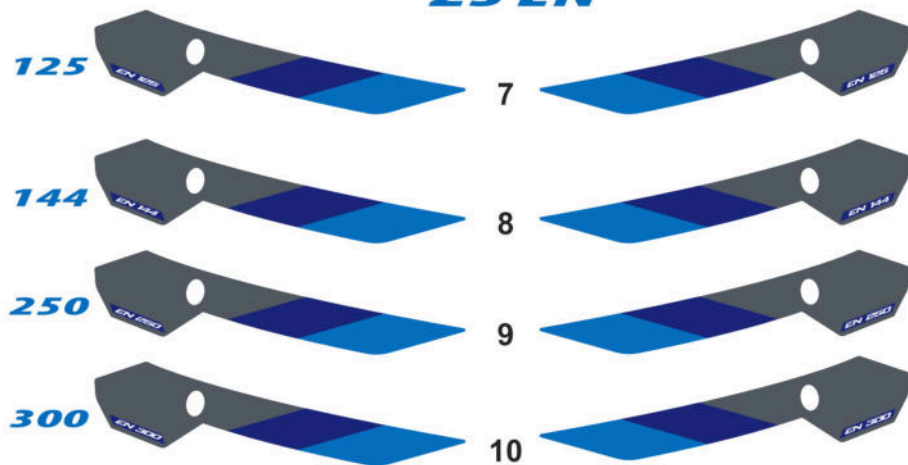

KA25-EN



2T125EN25  
2T 125 ES EN

KIT ADESIVI EN

18

Pos.	Codice	Q.tà	Note	Descrizione	Description
1	94317.25	1		KIT ADESIVI - TM MOTO - M.2025 S/POST.	
2	94104.25	1		ADESIVO PARAFANGO ANT. SM -TM MOTO- MY25	
3	94037.25	1		ADESIVO PARAFANGO ANT. -TM MOTO- MY25	
4	94161.25	1		ADESIVO PORTAFARO -TM MOTO- MY25	
5	94160.25	1		ADESIVO P.NUM.ANT. -TM MOTO- MY25	
6	94111.15	1		KIT ADESIVI FORC. KAYABA ROSSI	STICKERS KYB FORK RED
7	94291.125	1		KIT AD. LAT. P.NUM 2T EN 125 MY25	
8	94291.144	1		KIT AD. LAT. P.NUM 2T EN 144 MY25	
9	94291.250	1		KIT AD. LAT. P.NUM 2T EN 250 MY25	
10	94291.300	1		KIT AD. LAT. P.NUM 2T EN 300 MY25	
11	94292.250	1		KIT AD. LAT. P.NUM 4T EN 250 MY25	
12	94292.300	1		KIT AD. LAT. P.NUM 4T EN 300 MY25	
13	94292.450	1		KIT AD. LAT. P.NUM 4T EN 450 MY25	



2T125EN25  
2T 125 ES EN

CILINDRO 01 - 125 MX/EN CARB.  
CYLINDER 01 - 125 MX/EN CARB

1

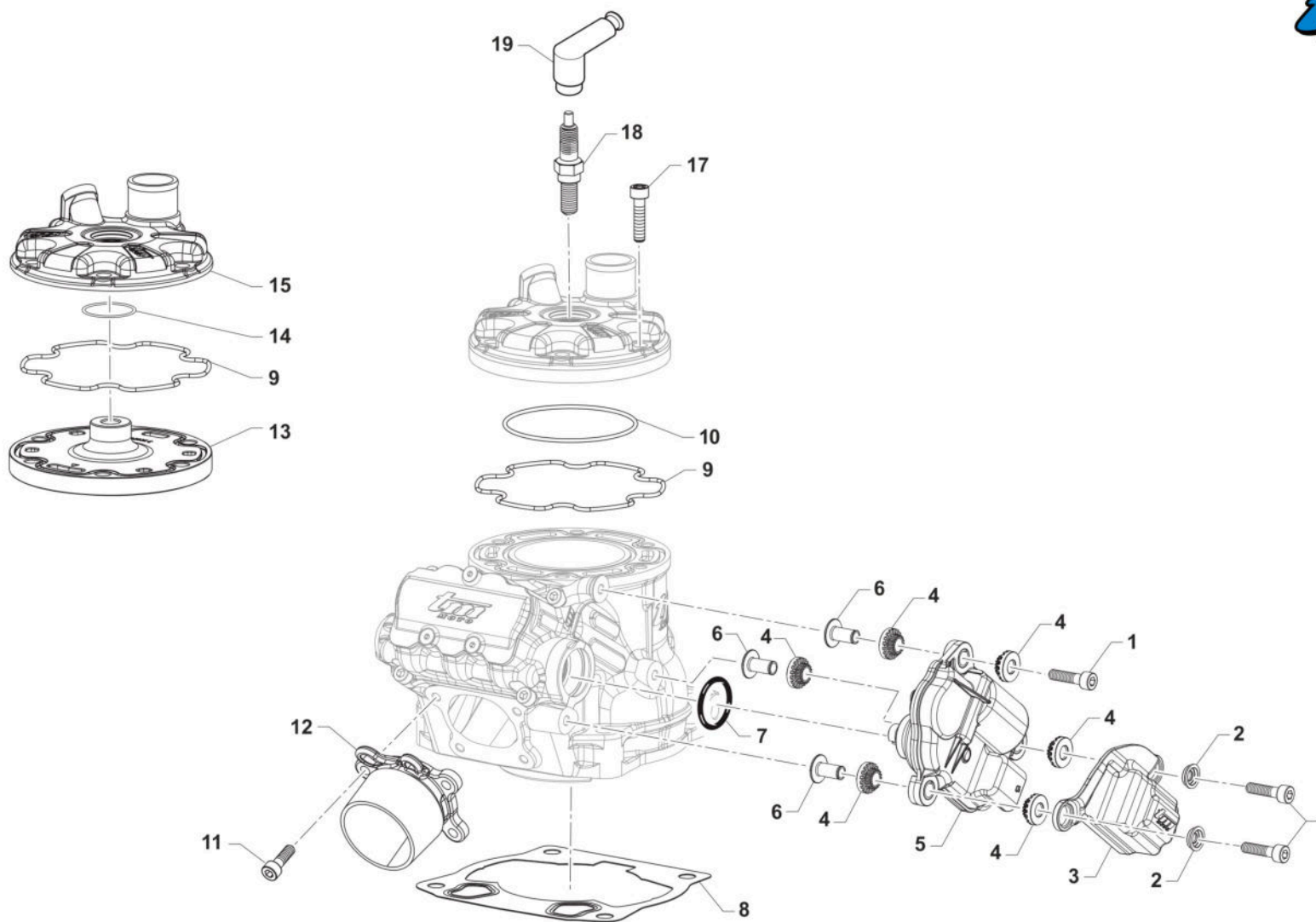

TM 0750.01



2T125EN25  
2T 125 ES EN

CILINDRO 01 - 125 MX/EN CARB.  
CYLINDER 01 - 125 MX/EN CARB

1

Pos.	Codice	Q.tà	Note	Descrizione	Description
1	49477	3		VITE TCEI 5X25 UNI 5931-912	BOLT TCEI 5X25
2	26238	2		BOCCOLA COVER ATTUATORE SBS 5X12X3	
3	67439	1		COVER ATTUATORE VALVOLA DI SCARICO SBS 11832 FD EVO MY2025	
4	21317	6		SILENT BLOCK 6.5X15X6.5 Z18	
5	68323	1		ATTUATORE VALVOLA DI SCARICO SBS 11832 FD EVO	
6	26241	3		BOCCOLA SOSP. ELAST. ATTUATORE VALV. SCARICO	
7	12047	1		O RING ORM 0220-30 22,0X3,0	
8	05538	1		GUARN. B/CIL 2T 125 ES MY 25 - 0,30	GASKET, CYLINDER 2S 125 ES MY25 - 0,30
8	05539	1		GUARN. B/CIL 2T 125 ES MY 25 - 0,40	GASKET, CYLINDER 2S 125 ES MY25 - 0,40
8	05540	1		GUARN. B/CIL 2T 125 ES MY 25 - 0,50	GASKET, CYLINDER 2S 125 ES MY25 - 0,50
8	05541	1		GUARN. B/CIL 2T 125 ES MY 25 - 0,60	GASKET, CYLINDER 2S 125 ES MY25 - 0,60
8	05542	1		GUARN. B/CIL 2T 125 ES MY 25 - 0,20	GASKET, CYLINDER 2S 125 ES MY25 - 0,20
9	12043	2		O RING PREFORMATO CIL. 125 MY 2025	
10	12003.1	1		O RING INT.TESTA 125/144 FKM 75 SH MARRONE	O-RING, INT. HEAD 125 / 144cc VITON
11	49474	4		VITE TCEI 5X16 UNI 5931	BOLT TCEI 5X16
12	13127	1		COLLETTORE SCARICO A 4 VITI M5 D38	
13	02035	1		CAMERA COMBUSTIONE TESTA MX EN 125 2T	COMBUSTION CHAMBER 2S 125 MX/EN MY25
14	12073	1		OR 20,00X2,00 ORM 0200-20 NBR 70	
15	02037	1		COPERCHIO TESTA 125 CARBURATORE MY 2025	
17	490048	6		VITE TCEI 7x30 8.8 5931-912	
18	F06105	1		CANDELA NGK CR9EIX CON/NIPPLO	SPARK PLUG NGK CR9EIX
19	21087	1		PIPETTA CANDELA SILICONE SCHERMATO 5K	



2T125EN25  
2T 125 ES EN

CILINDRO 02 - 125 MX/EN CARB.  
CYLINDER 02 - 125 MX/EN CARB

2

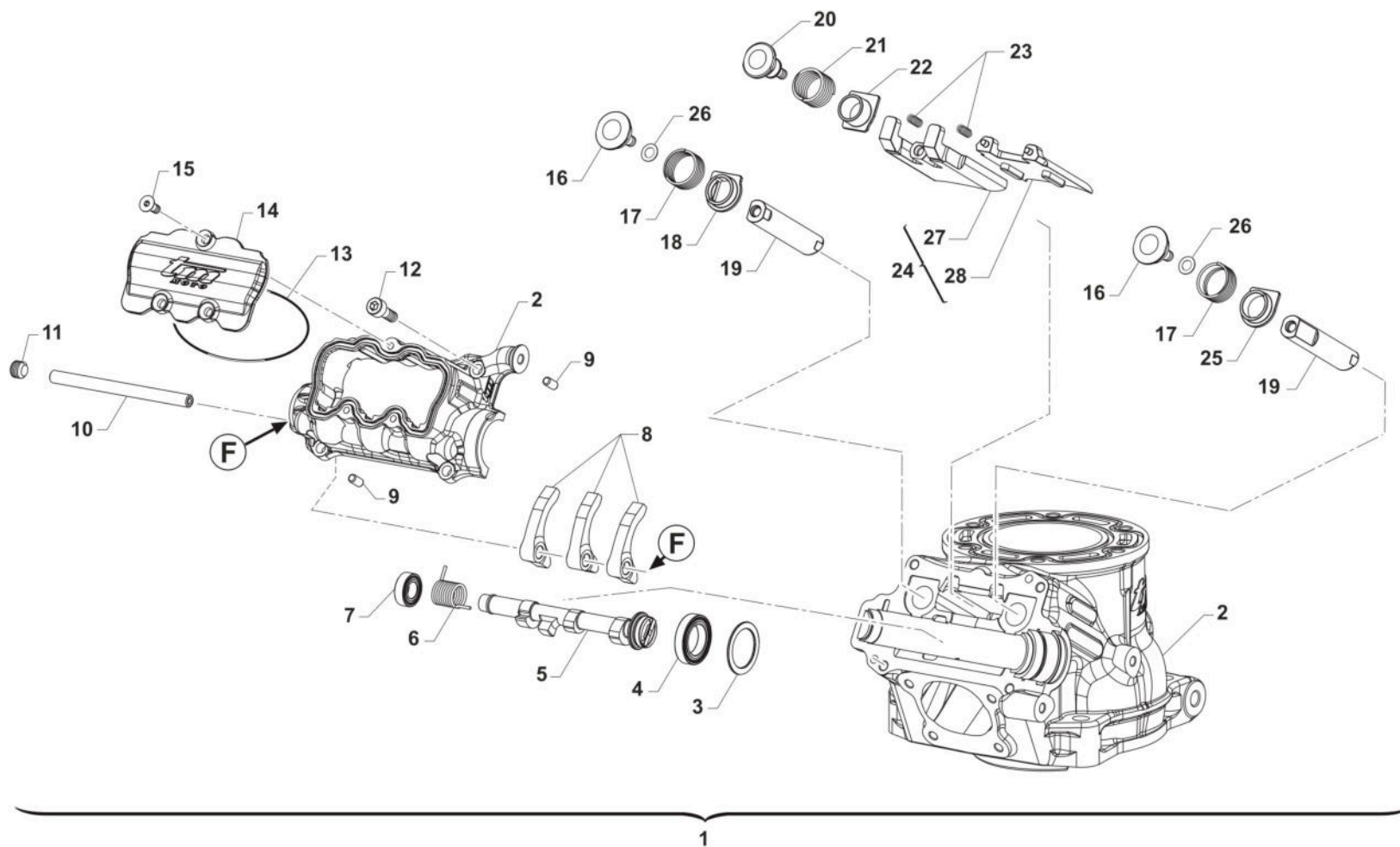

TM 0751



2T125EN25  
2T 125 ES EN

CILINDRO 02 - 125 MX/EN CARB.  
CYLINDER 02 - 125 MX/EN CARB

2

Pos.	Codice	Q.tà	Note	Descrizione	Description
1	01145	1		CILINDRO 125 MX/EN CARBURATORE MY 2025 CPL	CYLINDER 2S 125 MX/EN CARB. MY25 ASSY
2	01142	1		CILINDRO 125 MX/EN CARBURATORE MY 2025 NUDO	
3	48061	1		ANELLO TIPO PS DIN 988 19x26x1	
4	F03388	1		CUSCINETTO 61802-2RS1	BEARING 61802-2RS1
5	28271	1		ALBERO A CAMME PER CINEMATISMO VALVOLA DI SCARICO 2T SBS	
6	16263	1		MOLLA A TORSIONE D.INT. 9.3x1.3 St.9.6 SX R=1.531 Nmm/°	
7	F03389	1		CUSCINETTO 8X16X5 628/8 2RS	BEARING 628/8 2RS 8x16x5
8	28268	3		BILANCIERE AZIONAMENTO VALVOLA SCARICO 2T	
9	F19504	2		RULLO D.4 X 8	PIN D.4 X 8
10	28074	1		SPINA CILINDRICA TEMPRATA DIN 7979 D - 6x80	
11	49717	1		GRANO 8 X 6	GRUB SCREW 6x8
12	49473	4		VITE TCEI 5X14	BOLT TCEI 5X14
13	12028	1		OR COP. POMPA H2O 2T 250/300 M.18->	O-RING WATER PUMP COVER 2S 250/300 MY.18->
14	001269	1		COPERCHIO ISPEZIONE CINEMATISMO DI SCARICO 125 2T	
16	28269	2		ALBERO A CAMME PER CINEMATISMO VALVOLA DI SCARICO 2T	
17	16261	3		MOLLA A COMPRESSIONE MOLATA 32.0x17.8x1.1 St.6.0 K=0.770 N/mm	SPRING, BOOSTER 32.0x17.8x1.1 St.6.0 K=0.770 N/mm
18	26283	1		PIATTELLO INFERIORE BOOSTER ANTIROTAZIONE SINISTRO	
19	22096	1		SET BOOSTER VALVOLA DX+SX 125 2025 (22091% +22092%)	BOOSTERS, SET, RH+LH 2S 125 ES
20	26268	1		PIATTELLO SUPERIORE VALVOLA PARZIALIZZATRICE SCARICO	
21	16262	1		MOLLA A COMPRESSIONE MOLATA 32.0x16.45x1.25 St.6.75 K=1.420 N/mm	SPRING, EX. VALVE 32.0x16.45x1.25 St.6.75 K=1.420 N/mm
22	26266	1		PIATTELLO INFERIORE VALVOLA PARZIALIZZATRICE SCARICO	
23	16260	2		MOLLA A COMPRESSIONE 16.5x4.1x0.5 St.16 K=0.870N/mm	SPRING, COMPRESSION 16.5x4.1x0.5 St.16 K=0.870N/mm



2T125EN25  
2T 125 ES EN

CILINDRO 02 - 125 MX/EN CARB.  
CYLINDER 02 - 125 MX/EN CARB

2

Pos.	Codice	Q.tà	Note	Descrizione	Description
24	22095	1		VALVOLA GHIGL. 125 2025 (22089+22090)	VALVE, EXHUAST 2S 125 ES
25	26284	1		PIATTELLO INFERIORE BOOSTER ANTIROTAZIONE DESTRO	
26	F48407.010	1		RONDELLA 5x10x0,10 PS DIN 988	
26	F48407.020	1		RONDELLA 5x10x0,20 PS DIN 988	
26	F48407.030	1		RONDELLA 5x10x0,30 PS DIN 988	
26	F48407.050	1		RONDELLA 5x10x0,50 PS DIN 988	
27	22089	1		PRIMO STADIO VALVOLA PARZIALIZZATRICE SCARICO	
28	22090	1		SECONDO STADIO VALVOLA PARZIALIZZATRICE SCARICO	



2T125EN25  
2T 125 ES EN

# ALBERO MOTORE E PISTONE CRANKSHAFT AND PISTON

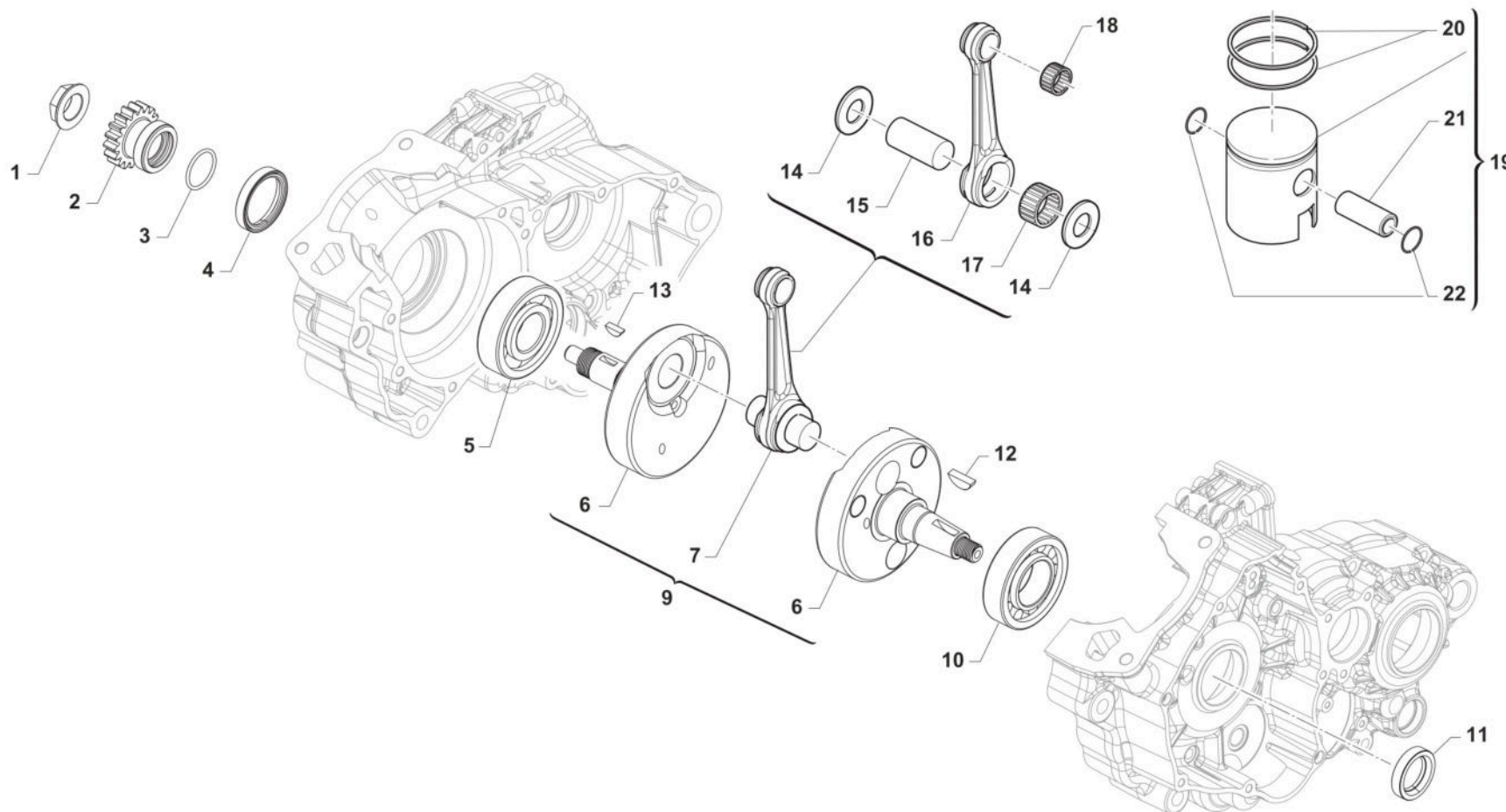

TM 0753





2T125EN25  
2T 125 ES EN

ALBERO MOTORE E PISTONE  
CRANKSHAFT AND PISTON

3

Pos.	Codice	Q.tà	Note	Descrizione	Description
1	F49816	1		DADO M18 x 1,25 SPECIALE 250N	
2	40322	1		PIGNONE COPPIA PRIMARIA Z18 MY2023	
3	12067	1		O RING 23X2	
4	04049	1		PARAOLIO FPJ 32x41x7	
5	03255	1		CUSCINETTO A SFERE ALB.MOTORE 125 M.13	BUSH, CRANKSHAFT 125 M.13
6	18291	1		COPPIA SEMIALBERI 125 Fi ES 2025	
7	18125.2	1		BIELLA 125Fi ASSE 22 x 50,4 CPL ASSE F.5	CONROD ASSY2 125 Fi PIN 22 x 50,4 mm Hole 5mm
9	18297	1		ALBERO MOTORE CPL 125 Fi ES 2025	
10	03026.1	1		CUSCINETTO ALBERO MOTORE NJ206	BEARING NJ206ET2XCS46
11	04039	1		PARAOLIO 22x33x7 PTFE	
12	49012	1		CHIAVETTA PIGNONE COPPIA 250	WOODRUFF KEY, 250/300 19x7,5x5
13	490035	1		LINGUETTA A DISCO UNI 6606 4x5	
14	18239.1	2		RONDELLA ARGENTATA D.22 X 1 v2 TONDA/MODIF.	
15	18091.4	1		ASSE ACCOP. 22 X 50.4 F.5	CRANKPIN 22 X 50,4 hole 5mm
16	18053.2	1		BIELLA ASSE 22 FORG. NUDA 109,8	CONROD D.22mm FORGED 109,8
17	17016	1		GABBIA ARGENTATA 222815 R.SF.	
18	19034	1		GABBIA SPINOTTO 15X19X17,3	TOP END B. 15X19X17,3
19	10029.94	1		PISTONE 53.94 125 ES 2025 2F CPL	PISTON 53.94 125 ES 2025 2R COMP.
19	10029.95	1		PISTONE 53.95 125 ES 2025 2F CPL	PISTON 53.95 125 ES 2025 2R COMP.
19	10029.96	1		PISTONE 53.96 125 ES 2025 2F CPL	PISTON 53.96 125 ES 2025 2R COMP.
19	10029.97	1		PISTONE 53.97 125 ES 2025 2F CPL	PISTON 53.97 125 ES 2025 2R COMP.
19	10029.98	1		PISTONE 53.98 125 ES 2025 2F CPL	PISTON 53.98 125 ES 2025 2R COMP.
20	11078	2		SEGMENTO D. 54 X 0,8 RIKEN/NISMO	PISTON RING D.54 X 0,8 Riken
21	09000	1		SPINOTTO PISTONE VERTEX 125	PISTON PIN VERTEX 125

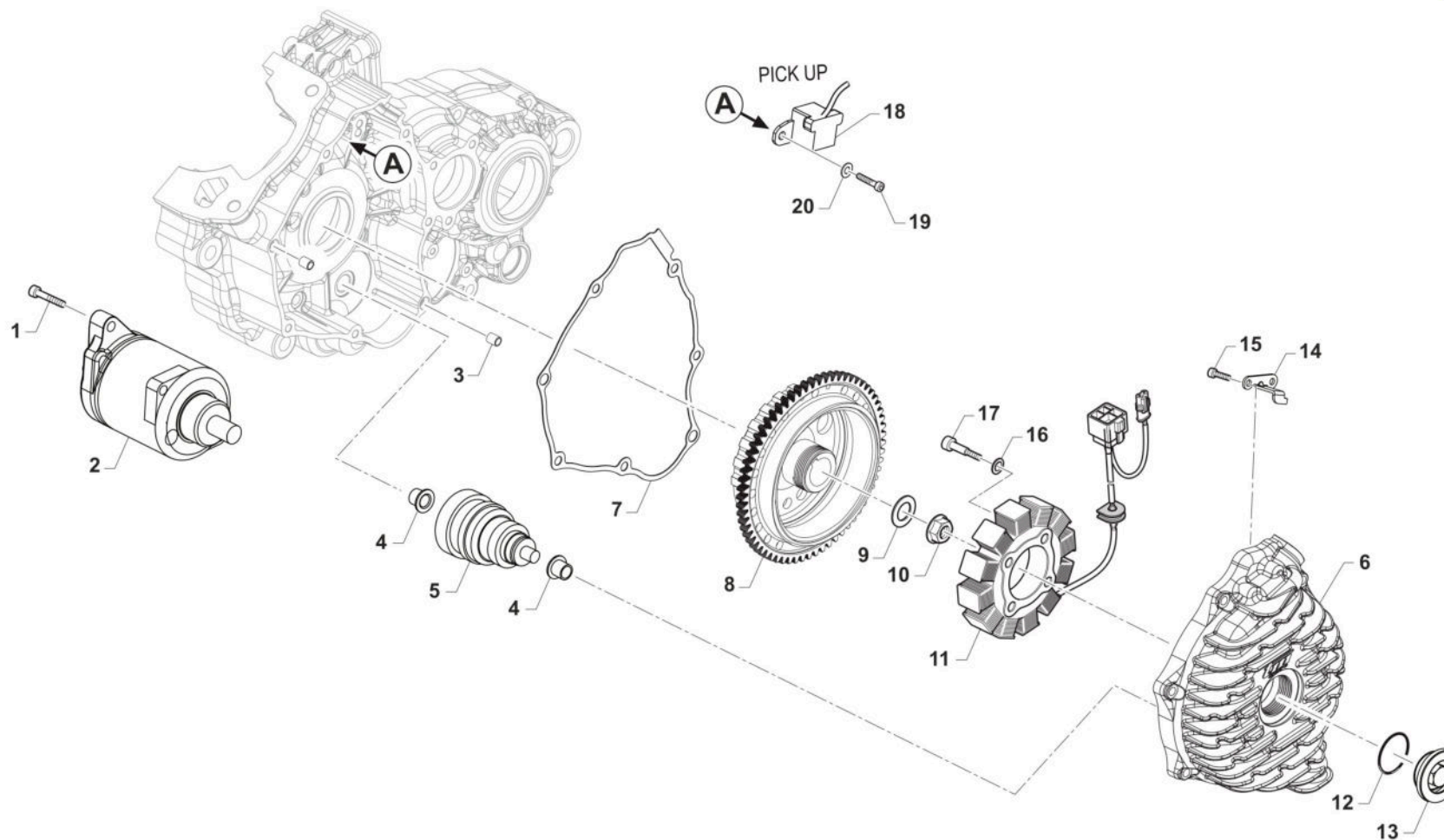

TM 0754



2T125EN25  
2T 125 ES EN

## ACCENSIONE CARBURATORE

4

Pos.	Codice	Q.tà	Note	Descrizione	Description
1	49485	2		VITE TCEI 6X25 UNI 5931	BOLT TCEI 6x25
2	68206	1		MOTORINO AVVIAMENTO 250/300 M18->	STARTER MOTOR 250/300 T.S. MY19->
3	26041	2		GRANO CENTRAGGIO D.7X8 F.5,2	DOWEL PIN 7 x 8 Hole 5,2
4	26256	2		BOCCOLA FLANGIATA BENDIX AVV. EL. 250/300 2T I.E.	FLANGE BUSH BENDIX EL.ST. 250/300 T.S. Fi
5	68207	1		BENDIX MOTORE 250/300 2T ES MY 2019	BENDIX
6	30394.1	1		COPERCHIO ACCENSIONE 2T 125 ES MY 2025 - 4 FORI	
7	05286	1		GUARNIZIONE COPERCHIO ACCENSIONE 2T 125 ES MY25	GASKET, IGNITION COVER 2S 125 ES MY 25
8	15258	1		ROTORE CPL IN PLASTONEODIMIO (da 15253.1)	
9	49613	1		RONDELLA ACCIAIO 12	STEEL WASHER 12
10	49056	1		DADO ACCENSIONE MX/E 12 x 1.25	NUT, IGNITION 100cc
11	F15547	1		STATORE KOKUSAN YS 9018 C. KOK / SUM	
12	F12322	1		O RING 2106	O-RING
13	49290	1		TAPPO COPERCHIO ACC. 250/300 2T MY 2019(PUO' SOSTITUIRE F49833)	CAP IGNITION COVER 250/300 2S MY19
14	F30945	1		PROTEZIONE CAVI ACC.NE 250N	PROTECTION IGNITION WIRES 250N
15	490047	2		VITE TCEI 7x35 8.8 5931-912 BRU	
16	49866	4		RONDELLA 4 x 12 x 1	
17	49384	4		VITE TCEI 4X35	
18	F15478	1		PICK-UP KOKUSAN	PICK-UP KOK PU5157
19	49472	2		VITE TCEI 5X12 UNI 5931-912 Brun	BOLT TCEI 5X12
20	49601	2		RONDELLA 5X11	WASHER 5x11

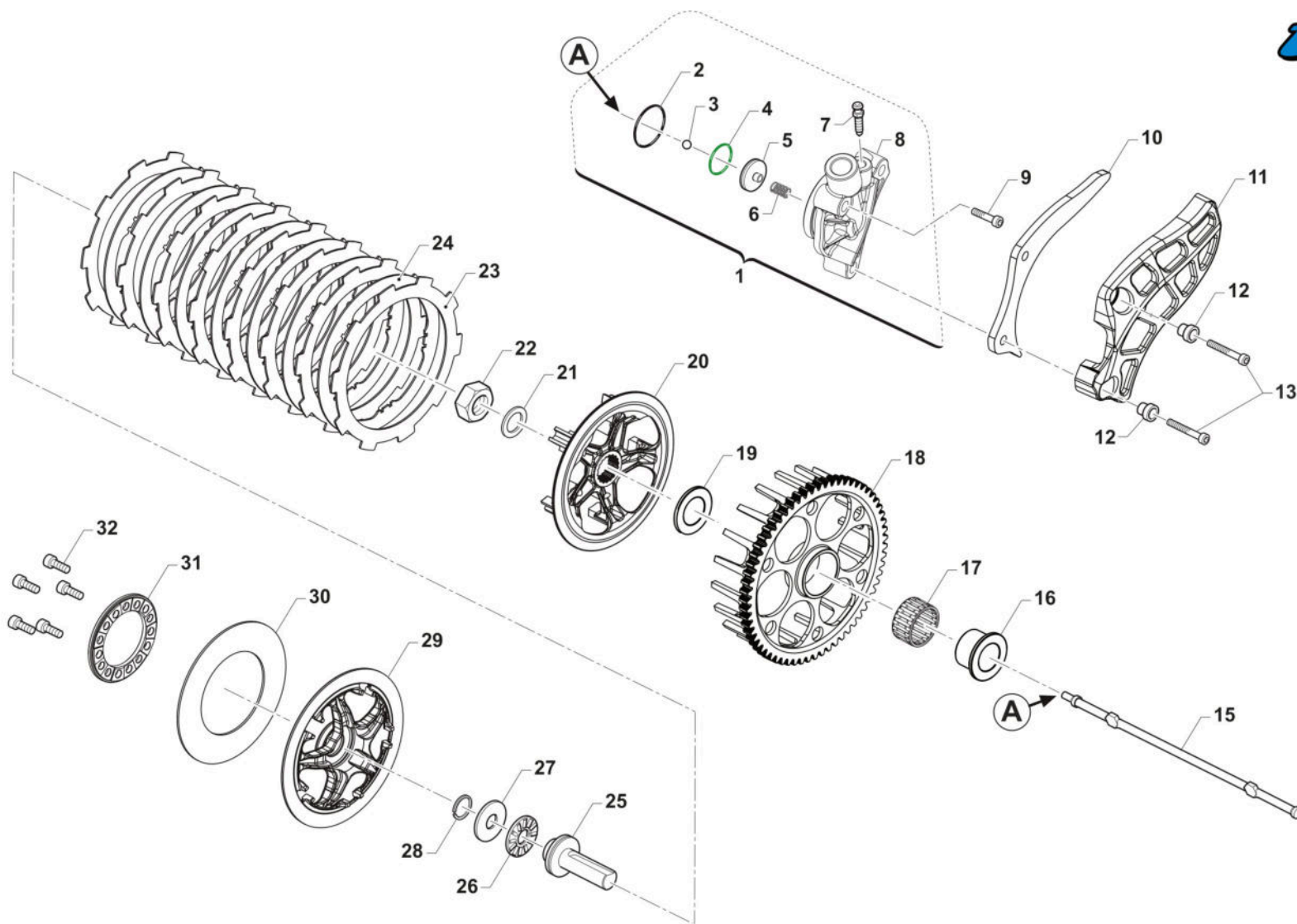



2T125EN25  
2T 125 ES EN

FRIZIONE  
CLUTCH

5

Pos.	Codice	Q.tà	Note	Descrizione	Description
1	30375	1		ATTUATORE FRIZ. Ø26 125 MY 25 CPL	OUTPUT HYDR. CLUTCH 2S 125 ES MX/EN ASSY
2	12091	1		O RING CORPO CARTUCCIA FR.COMP	O-RING
3	F19517	1		SFERA X PIST.FRIZ.IDRAUL.250N	BALL IDR. CLUTCH PISTON 250N
4	12259	1		O RING PISTONE FR.125/250 VITON (Verde)	O-RING, CLUTCH PISTON 125/250
5	F35554	1		PISTONCINO POMPA FRIZIONE	PISTON CLUTCH MASTER CYLINDER
6	F16470	1		MOLLA CONTR. PIST/FRI 450Fi'15	
7	35264	1		VITE SPURGO OLIO FRIZ.IDR.6X1	SCREW AIR BLEED HYDRAUL.CLUTCH
8	30371	1		CORPO ATTUATORE FRIZ. Ø26 125 MY 25	
9	49477	1		VITE TCEI 5X25 UNI 5931-912	BOLT TCEI 5X25
10	40083	1		PROTEZIONE PIGNONE ERGAL 250/300 2T MX/SMX MY 25	
11	40075	1		PROTEZIONE PIGNONE 250/300 IE	PROTECTION, PLASTIC
12	26211	2		BOCCOLA PROT. PIGNONE 250 F.5	COLLAR, SPROCKET 250cc H.5
13	49535	2		VITE TCEI 5X35 UNI 5931-912	BOLT TCEI 5X35
15	35067	1		ASTINA FRIZIONE IDRAULICA 125 ES MY 2025	ROD, CLUTCH 2S 125 ES
16	26197	1		BOCCOLA INGR.TRASM.PRIM. 125 2022	COLLAR, CLUTCH OUTER 2S 125 ES
17	19111	1		GABBIA A RULLI K26x30x17	BEARING, NEEDLE, 26x30x17
18	40323	1		COPPIA PRIM. 125 Z63 MY2023	
19	48048	1		SPESSORE INGR.TRASM. PRIM.125 2022 (20X34.8X2.5)	SPACER, OUTER CLUTCH, 20x34,8x2,5
20	25101	1		TAMBURELLO FRIZIONE	
21	F48353	1		SPESSORE PS 18X25X1	SPACER 18x25x1
22	49060	1		DADO TAMBUR.FRIZ. ALB.PRIM. 250/300 M18X1.5	NUT, CLUTCH CENTER 250cc
23	35056	8		DISCO FRIZ. GUARN. 125/144Fi 2T MY2025	DISK, CLUTCH 2S 125 ES
24	35055	7		DISCO FRIZ. ACC. 125/144Fi 2T SP.1,2 MY24	
25	F35582	1		FUNGO FRIZIONE IDRAULICA 2015	PIECE, CLUTCH LIFTER
26	19022	1		GABBIA A RULLI RAD. AXK 1528	BUSH CAGE AXK 1528, RADIAL
27	19023	1		RONDELLA GABBIA RULLI AS 1528	WASHER, NEEDLE CAGE AS 1528
28	09006	1		ANELLINO FERMA SPINOTTO 80/85/100	CLIP, PISTON PIN 80/85/100cc
29	25102	1		SPINGIDISCO FRIZIONE	



2T125EN25  
2T 125 ES EN

FRIZIONE  
CLUTCH

5

Pos.	Codice	Q.tà	Note	Descrizione	Description
30	16077	1		MOLLA FRIZIONE 2T 125 ES MY 25	SPRING, CLUTCH 2S 125 ES MY25
31	25103	1		ELEMENTO FISSAGGIO MOLLA FRIZIONE	
32	49473	1		VITE TCEI 5X14	BOLT TCEI 5X14



2T125EN25  
2T 125 ES EN

# CARTER FRIZIONE CLUTCH CASE

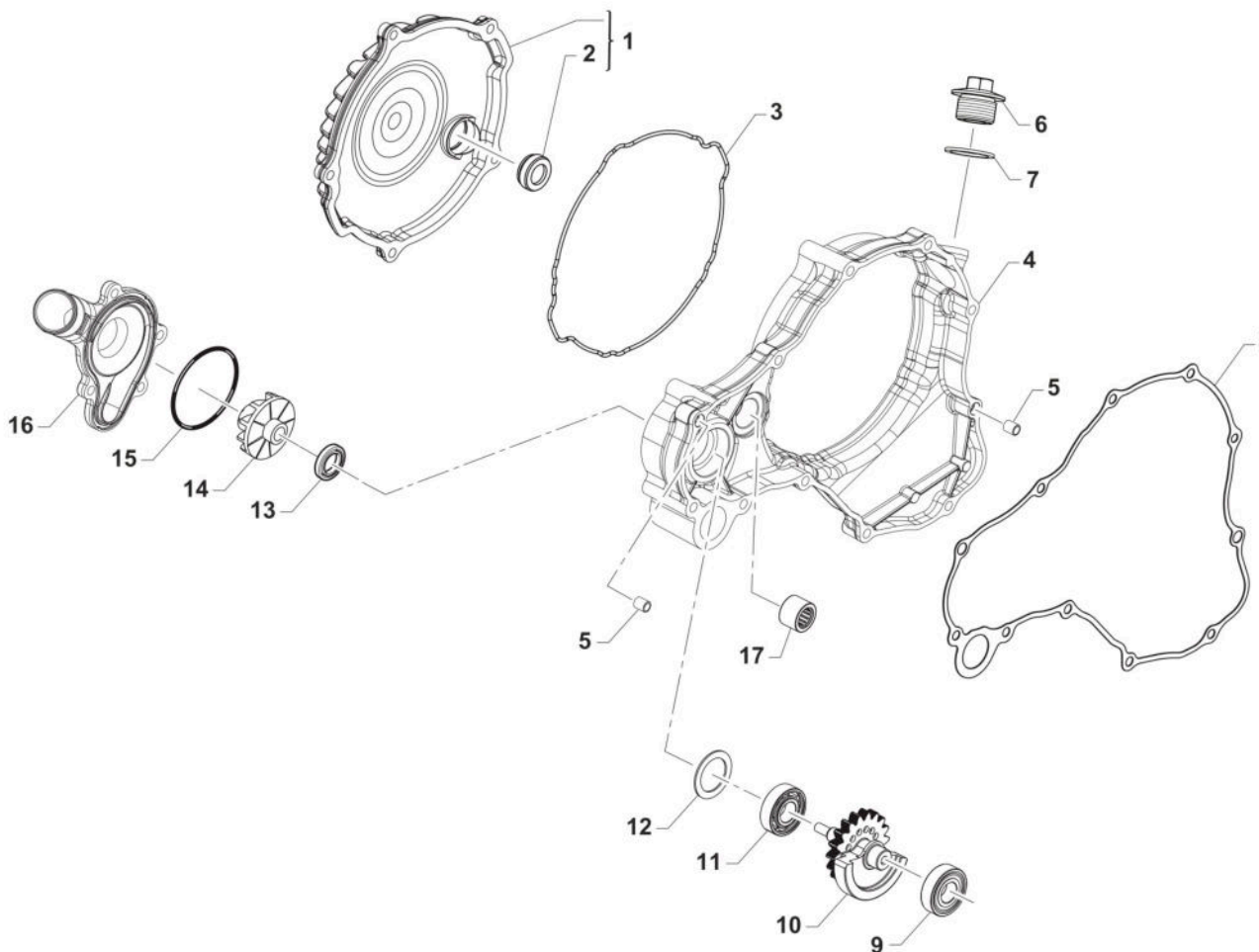

TM 0756



2T125EN25  
2T 125 ES EN

CARTER FRIZIONE  
CLUTCH CASE

6

Pos.	Codice	Q.tà	Note	Descrizione	Description
1	30370.1	1		COPERCHIO FRIZIONE 125 MY 2025 COMPLETO DI OBLO' 04019	
2	04019	1		OBLO' OLIO 125 - LIVELLO OIL Fi 2T	OIL WINDOW 125 K MF1 MF2
3	12270	1		O RING SAGOMATO COP. FRIZIONE 125 FI 2T 2025	
4	30369	1		CARTER FRIZIONE 125 2T MY 2025	
5	26041	2		GRANO CENTRAGGIO D.7X8 F.5,2	DOWEL PIN 7 x 8 Hole 5,2
6	F49844	1		TAPPO CARICO OLIO 250N	
7	F49920	1		RONDELLA ALL 20.4X26X1.5	WASHER 20,4X26X1,5 ALUM.
8	05287	1		GUARNIZIONE CARTER FRIZIONE 2T 125 ES MY25	GASKET, CLUTCH CASE 2S 125 ES MY 25
9	03094	1		CUSCINETTO A SFERE 12x28x8 6001-2RSH/C3	
10	40324	1		INGRANAGGIO POMPA ACQUA E CONTRALBERO 125 ES MY2025	
11	03093	1		CUSCINETTO A SFERE 12x28x8 6001 C4	
12	48062	1		RONDELLA 20x28x1 PS DIN 988	
13	F04363	1		PARAOLIO 8X22X5 250/09->	OIL SEAL 8x22x5 (250F/09)
14	F28679	1		GIRANTE POMPA ACQUA 250N	IMPELLER, H2O PUMP 250Fi
15	12046	1		X-RING QUADRING 2250 = 2.37 (63.22x1.78)	
16	30393	1		COPERCHIO POMPA ACQUA 125 MY 2025	
17	03092	1		CUSCINETTO A RULLINI 10x17x12	





2T125EN25  
2T 125 ES EN

# BASAMENTO E PACCO CASE AND REEDS BOX

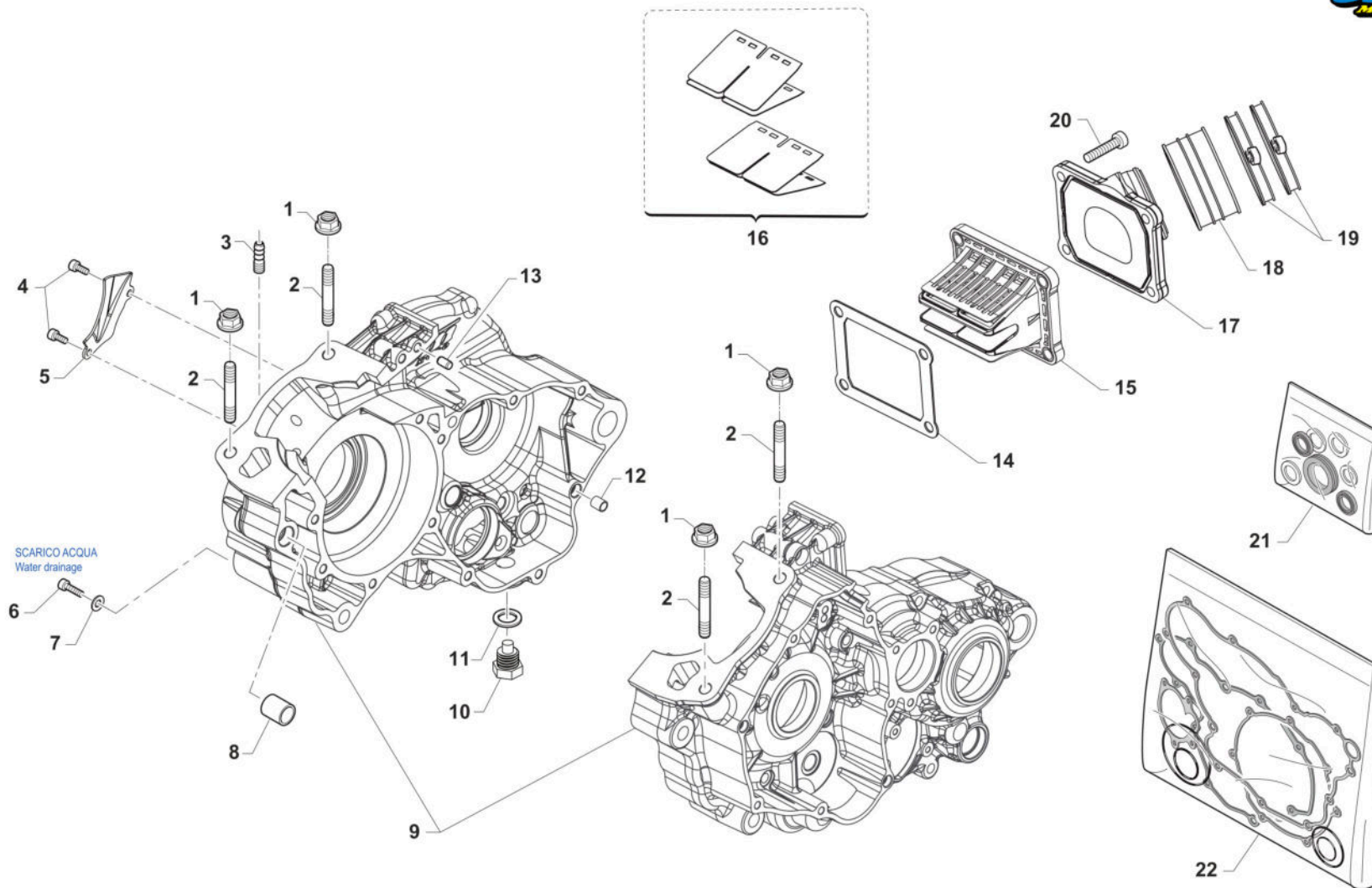

TM 0757



2T125EN25  
2T 125 ES EN

BASAMENTO E PACCO  
CASE AND REEDS BOX

7

Pos.	Codice	Q.tà	Note	Descrizione	Description
1	49191	4		DADO M 8 X 1,25 CH. 10 FLANGIATO	NUT, FLANGE M8 x 1,25
2	49028	4		PRIGIONIERO CILINDRO M 8 X 52 125 2025	
3	49004	1		RACCORDO SFIATO CARTER	PIPE, CRANKCASE BREATHER
4	49580	2		VITE TCEI 4X10 5931-912 Brun	BOLT
5	26162	1		PIASTRINO CONV.OLIO 250/300 18	PLATE
6	49480	1		VITE TCEI 6X10 UNI 5931	BOLT TCEI 6X10
7	49104	1		RONDELLA 6 x 10 x 1,5 ALLUMINIO	WASHER 6 x 10 x 1.5 ALUMINUM
8	F26428	1		GRANO RIFERIMENTO 12X13 F10.2	GRUB SCREW 12X13 H.10,2mm
9	30367	1		BASAMENTO MOTORE 2T 125 ES MY 2025	
10	49301	1		TAPPO OLIO C/CALAM. 2T	OIL PLUG WITH MAGNET
11	49103	1		RONDELLA 14X20X1,5 ALLUMINIO	WASHER, 14 X 20 X 1.5 ALUMINUM
12	F26304	1		GRANO RIFERIMENTO 6.1X8X9.5 4T	GRUB SCREW 6.5X8XX9.5 4S
13	19006	1		RULLINO 5 X 8	PIN 5 X 8, CLUTCH ROD
14	05631	1		GUARN. PACCO LAMELLE VFORCE 3 E VFORCE 4X	GASKET, REEDS BOX 2S 125 ES MY25
15	20259	1		PACCO LAMELLARE VFORCE 4R TM	
16	20098	1		LAMELLE V-FORCE 4X 125 2025	
17	13129	1		COLLETTORE ASPIRAZIONE 125 2T CARBURATORE	
18	13009	1		MANICOTTO COLLETTORE ASP.97/14	MANIFOLD RUBBER,INTAKE M.97/14
19	51054	2		FASCETTA SM9 D.52	CLAMP SM9 D.52mm
20	49538	4		VITE TCEI 6X22 UNI 5931	
21	04046	1		KIT PARAOLI 125 ES MY 2025	
22	05632	1		KIT GUARN. + OR 125 ES MY 2025	GASKETS + OR KIT 2S 125 ES MY25



2T125EN25  
2T 125 ES EN

# COMANDO CAMBIO GEARSHIFT MECHANISM

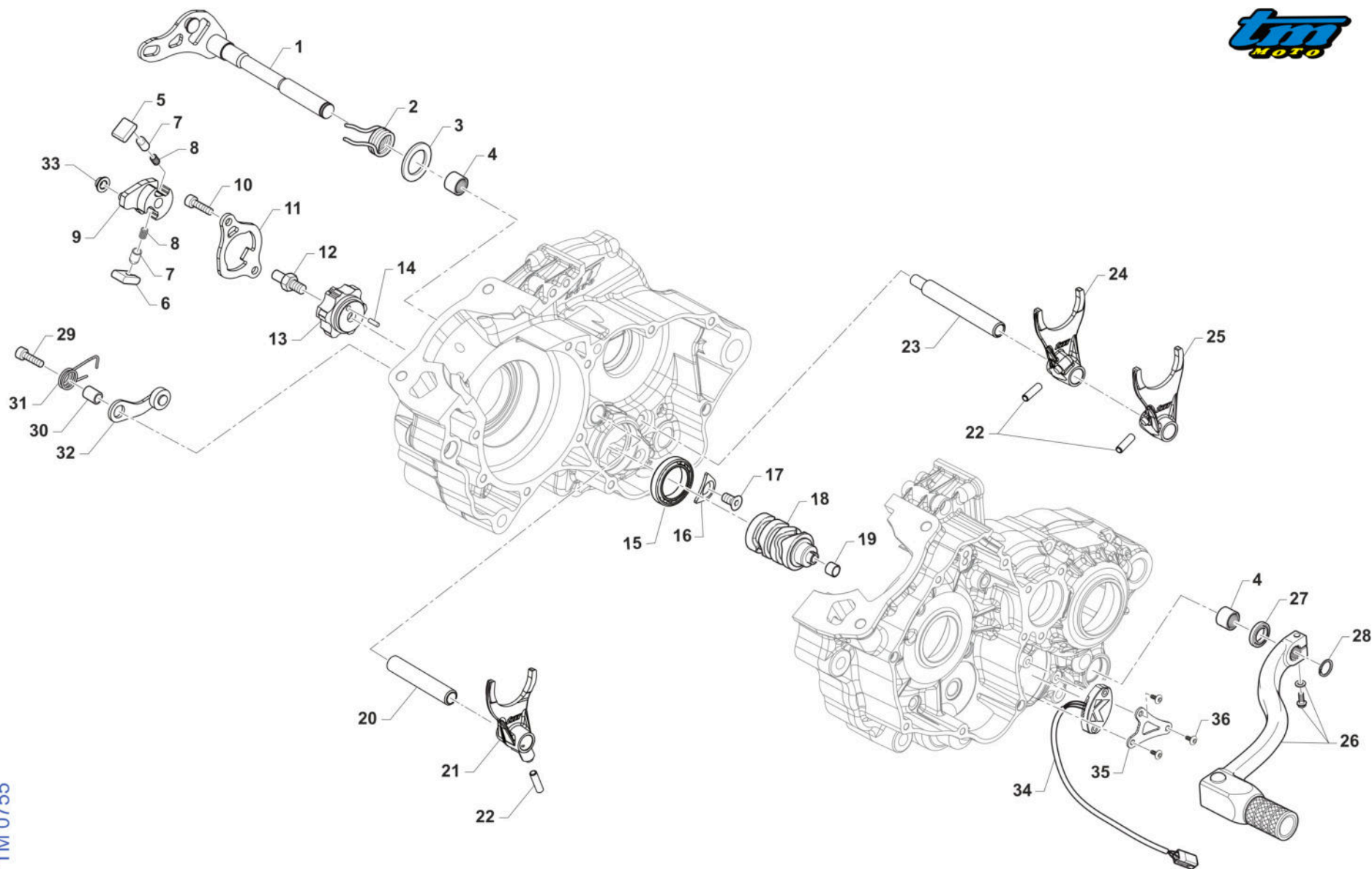

TM 0755



2T125EN25  
2T 125 ES EN

COMANDO CAMBIO  
GEARSHIFT MECHANISM

8

Pos.	Codice	Q.tà	Note	Descrizione	Description
1	28105	1		ALBERO COMANDO CAMBIO 250/300 IE CPL	SHAFT, GEARSHIFT 250/300 IE CPL
2	16065	1		MOLLA RITORNO LEVA CAMBIO 250 2T IE	SPRING, RETURN GEAR LEVER 250 2S EI
3	49073	1		RONDELLA 12,1X22X1	WASHER 12,1X22X1 125 MF1/2
4	19060	2		ASTUCCIO A RULLI HK 1212	NEEDLE CAGE HK 1212
5	F26587	1		CRICCHETTO SX 2T 250/300 ES	RATCHET, LF GEAR (HT) 250 M3
6	F26588	1		CRICCHETTO DX 2T 250/300 ES	RATCHET, RH GEAR (HT) 250 M3
7	F26592	2		PUNTALE CRICCHETTO 2T 250/300 ES	PIN, RATCHET GEAR (HT)
8	F16469	2		MOLLA PER PUNTALE 2T 250/300 ES	SPRING, GEARBOX PIN EDM
9	F26620	1		PORTACRICCHETTI HT 2T 250/300 ES	GEAR
10	49481	2		VITE TCEI 6X12	BOLT TCEI 6X12
11	26160	1		PIASTRINO RIENTRO CRIC.250 M18	PLATE
12	F49873	1		PERNO FILETTATO PORTACRICCHETTI (HT) 2T 250/300 ES	THREADED PIN FOR RATCHET HOLDER (HT)
13	26181	1		TESTA ALBERO DESMO ROT.D12 125/144 2T M22	
14	F19504	1		RULLO D.4 X 8	PIN D.4 X 8
15	F03381	1		CUSCINETTO 61805	BEARING 61805
16	F48352	1		PIASTRINO FISSA CUSCINETTO D72	PLATE
17	49403	1		VITE TSEI 6X12 ZINCATO	SCREW TSEI 6x12
18	33262	1		ALBERO DESMO 2T 125 ES 6M CPL MY 2025	
19	26260	1		BOCCOLA ALB. DESMODROMICO 250/300 2T I.E.	BUSH
20	33260	1		PERNO FORCHETTA AP 250/300 MY19	PIN, MAINSHAFT FORK
21	33028	1		FORCHETTA ALB.PRIM. 125/144 2T 5^/6^ (2022)	FORK, MAINSHAFT 2S 125 ES
22	F19533	3		RULLO D.6 X 15	PIN
23	33025	1		PERNO FORCHETTA AS 250/300 MY19	PIN, COUNTERSHAFT FORKS
24	33023	1		FORCHETTA A.S.1^3^ 250/300 M18 1A E 3A	FORK 1, COUNTERSHAFT
25	33027	1		FORCHETTA ALB.SEC. 250/300 2T 6M 2^/3^ (2020)	FORK 2, COUNTERSHAFT
26	43049	1		LEVA CAMBIO 2T (485) MY19->	GEAR LEVER 250 / 300 T.STR. EL.ST. M.19->
27	04038	1		PARAOLIO LEVA CAMBIO 250/300 2T I 12x20x5 l.parapolv.	OIL SEAL GEAR LEVEL 250/300 2S Fi 12x20x5
28	49212	1		SEEGER E12 LEVA CAMBIO	CIRCLIP D.12 - EXTERNAL



2T125EN25  
2T 125 ES EN

COMANDO CAMBIO  
GEARSHIFT MECHANISM

8

Pos.	Codice	Q.tà	Note	Descrizione	Description
29	49485	1		VITE TCEI 6X25 UNI 5931	BOLT TCEI 6x25
30	26007	1		DISTANZIALE MOLLA BLOCCAMARCE	SPACER, STOP GEAR SPRING
31	F16447.3	1		MOLLA BLOCCA MARCE 250 4T D.FILO 2.4	
32	26095	1		PIASTRINO BLOCCAMARCE KV/95CPL + MOTO	PLATE, STOP GEAR KV/95 ASSY
33	F26593	1		BOCCOLA FLANGIATA PORTACRICCHETTO F26620	LEVER BUSH
34	F08459	1		SENSORE POSIZIONE CAMBIO eM060 CPL G.ANTIORARIO	
35	26280	1		PIASTRINO FISSAGGIO SENSORE POSIZIONE CAMBIO 125 2T	
36	490047	3		VITE TCEI 7x35 8.8 5931-912 BRU	



2T125EN25  
2T 125 ES EN

### CAMBIO EN/SMR GEARBOX

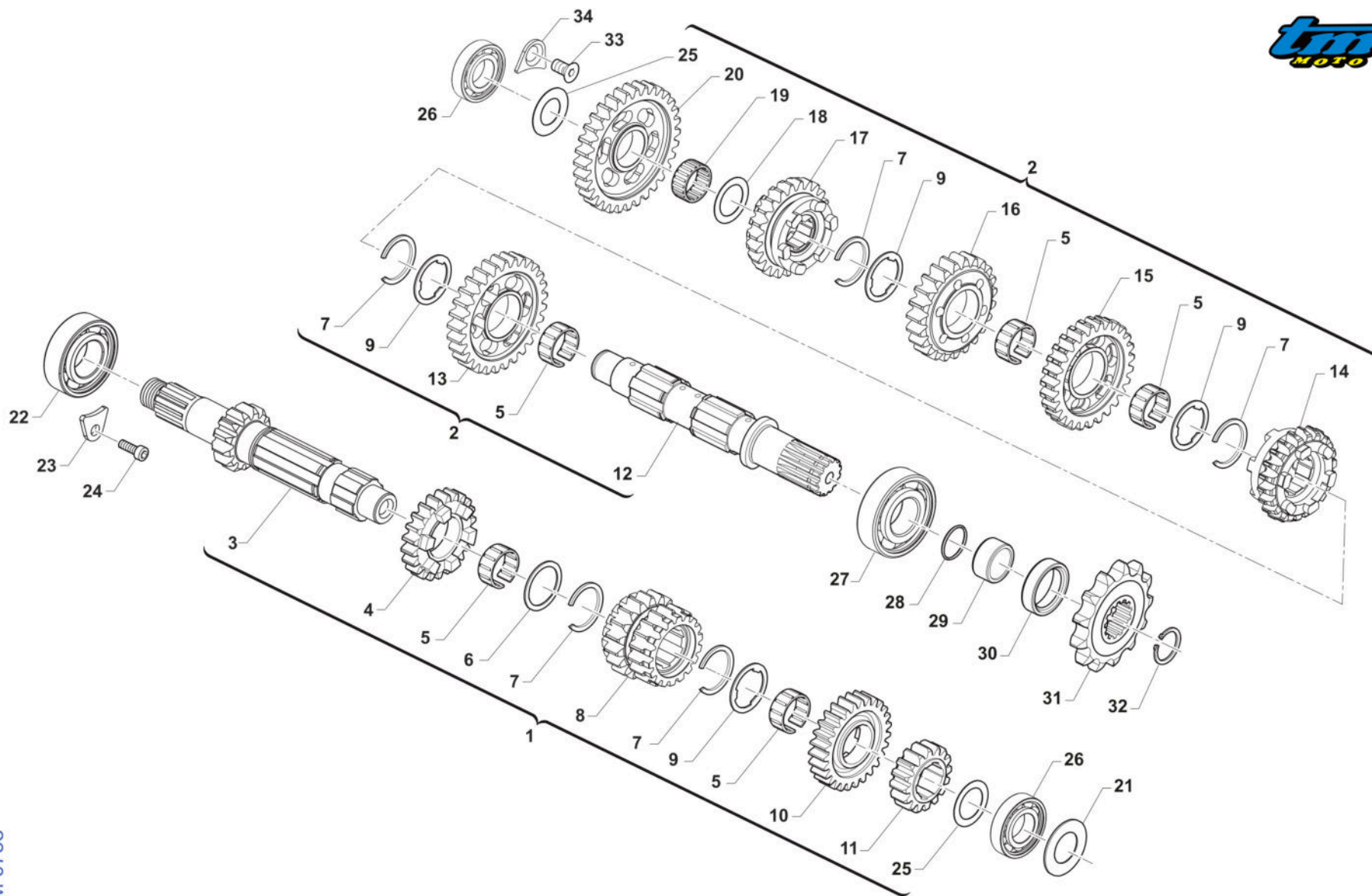

TM 0758



2T125EN25  
2T 125 ES EN

CAMBIO EN/SMR  
GEARBOX

9

Pos.	Codice	Q.tà	Note	Descrizione	Description
1	40084	1		ALBERO PRIM. CPL 125 ES 2025 END/SMR	
2	40085	1		ALBERO SECOND. CPL 125 ES 2025 END/SMR	
3	40721	1		ALBERO PRIMARIO Z 13 125FI 2T EN 2020	
4	40724	1		INGR A.P. 5a Z 21 125FI 2T MX/EN 2020	
5	F19524	5		GABBIA A RULLI 22X26X10 TAGL.	NEEDLE BEARING 22 X 26 X 10
6	48259	1		SPESSORE D.25.1 x 31 x 1.5 CAMBIO INT.55 6M	
7	F49869	5		SEEGER SW 24 (EST.) "SEEGER"	CIRCLIP SW 24 (EXTERNAL)
8	40723	1		INGR A.P. 3/4a Z 18/18 125FI 2T MX/EN 2020	
9	48258	4		SPESSORE DENT.CAMBIO INT.55 6M	SPACER GEAR INT.55 6S
10	40726	1		INGR A.P. 6a Z 22 125FI 2T EN 2020	
11	40722	1		INGR A.P. 2a Z 16 125FI 2T MX/EN 2020	
12	40727	1		ALBERO SECONDARIO 125FI 2T MX/EN 2020	
13	40730	1		INGR A.S. 2a Z 29 125FI 2T MX/EN 2020	
14	40735	1		INGR A.S. 6a Z 20 125FI 2T EN 2020	
15	40731	1		INGR A.S. 3a Z 27 125FI 2T MX/EN 2020	
16	40732	1		INGR A.S. 4a Z 23 125FI 2T MX/EN 2020	
17	40733	1		INGR A.S. 5a Z 23 125FI 2T MX/EN 2020	
18	F48353	1		SPESSORE PS 18X25X1	SPACER 18x25x1
19	F19514	1		GABBIA A RULLI 18X22X10	NEEDLE CAGE 18X22X10
20	40729	1		INGR A.S. 1a Z 32 125FI 2T EN 2020	
21	48063	1		RASAMENTO Ø17,3 x Ø32,9 x 0,30	
22	03164.1	1		CUSCINETTO SFERE (20x42x12) 6004 C3	BEARING (20x42x12) 6004 C3
23	26156	1		PIASTRINO BLOC.CUSC.C.A.125 OK /250/300	PLATE, BEARING HOLDER 125 OK
24	49962	1		VITE TCEI 6X12 BASSA / F.GUIDA	BOLT
25	48253	2		SPESSORE CAMBIO 17X30X1 250	SPACER, GEAR BOX 250cc 17X30X1
26	03165	2		CUSCINETTO SFERE (17x35x8) 16003 C3	BEARING (17x35x8) 16003 C3
27	F03368	1		CUSCINETTO 62/22 C3 22x50x14	BEARING 62/22 C3 22x50x14
28	F12320	1		O RING BOCCOLA PIGNONE 250/09	O-RING NBR 2087



2T125EN25  
2T 125 ES EN

CAMBIO EN/SMR  
GEARBOX

9

Pos.	Codice	Q.tà	Note	Descrizione	Description
29	F26421	1		DISTANZ. PIGNONE CATENA 250N	SPACER SPROCKET CHAIN 250N
30	04113	1		PARAOLIO 28 X 38 X 7	OIL SEAL 28 x 38 x 7
31	F40889	1		PIGNONE CATENA 250N - Z13	SPROCKET 13T, DRIVE 250Fi
31	F40933	1		PIGNONE CATENA 250N - Z14	SPROCKET 14T, DRIVE 250Fi
31	F40956	1		PIGNONE CATENA 250N - Z12	SPROCKET 12T, DRIVE 250Fi
32	49217	1		SEEGER E22 ANELLO ALB/S	CIRCLIP D.22 - COUNTERSHAFT
33	49403	1		VITE TSEI 6X12 ZINCATO	SCREW TSEI 6x12
34	F48352	1		PIASTRINO FISSA CUSCINETTO D72	PLATE





2T125EN25  
2T 125 ES EN

VITI MOTORE  
BOLTS

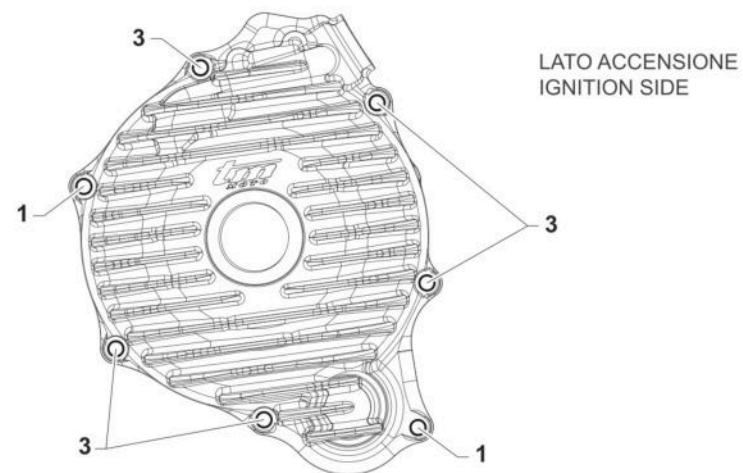
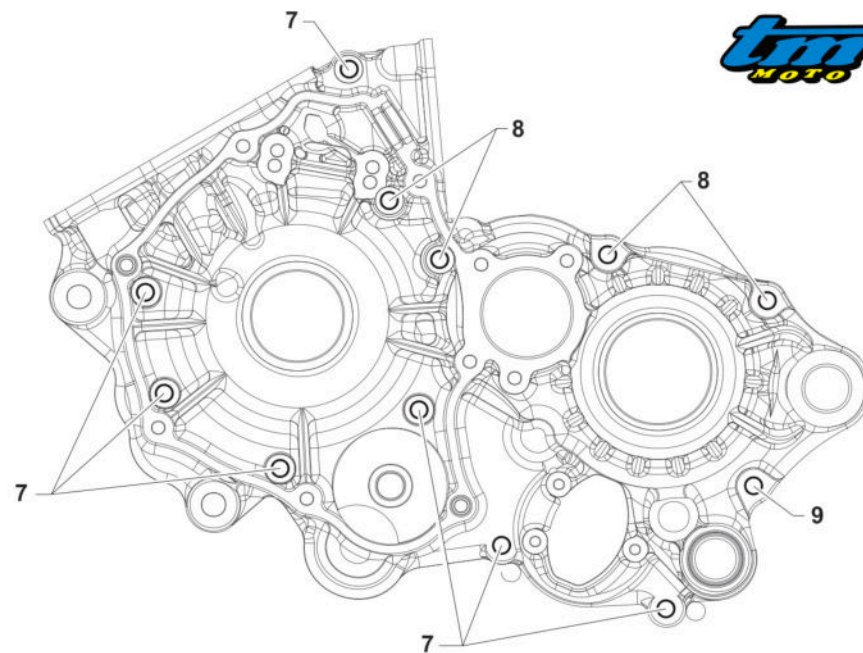
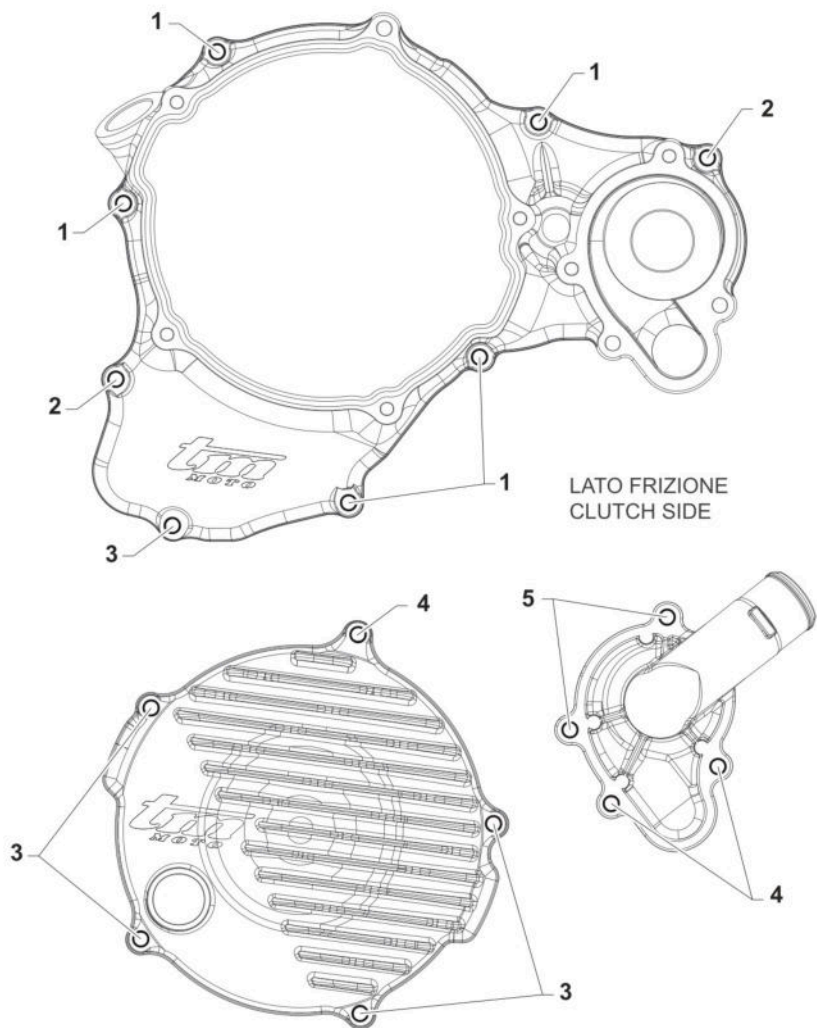

TM 0759



2T125EN25  
2T 125 ES EN

VITI MOTORE  
BOLTS

10

Pos.	Codice	Q.tà	Note	Descrizione	Description
1	49477	7		VITE TCEI 5X25 UNI 5931-912	BOLT TCEI 5X25
2	49478	2		VITE TCEI 5X30 UNI 5931	BOLT TCEI 5X30
3	49476	10		VITE TCEI 5X20 UNI 5931-912 YZPL	BOLT TCEI 5X20
4	49578	3		VITE TCEI 5X55	BOLT TCEI 5X55
5	49474	2		VITE TCEI 5X16 UNI 5931	BOLT TCEI 5X16
7	49489	7		VITE TCEI 6X45 UNI 5931	BOLT TCEI 6x45
8	49491	4		VITE TCEI 6X55	BOLT TCEI 6X55
9	49492	1		VITE TCEI 6X60	BOLT TCEI 6X60



2T125EN25  
2T 125 ES EN

MONO TM

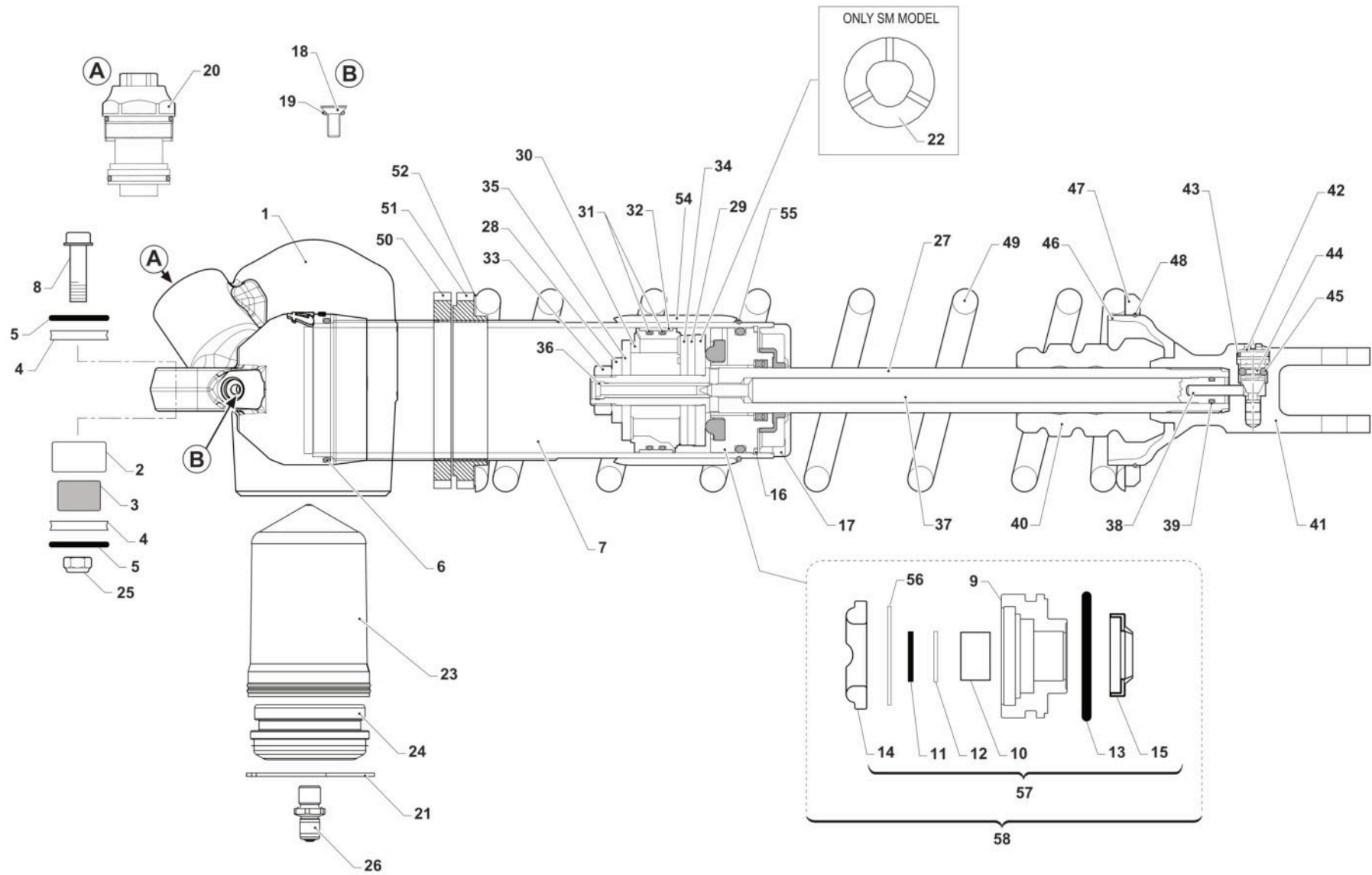

TM-MONO-2022



2T125EN25  
2T 125 ES EN

MONO TM

3

Pos.	Codice	Q.tà	Note	Descrizione	Description
1	72259	1		TESTINA MONO TM 2T 2022	
2	19101	1		GABBIA RULLINI DL 1812 KYU	BUSH NEEDLE CAGE DL 18/12
3	73213	1		BOCCOLA 18 X 12.3 F.10 TRIANG. + MONO	BUSH, 18 X 12.3 X 5
4	F26536	2		SPESSORE PER TESTINA AMM.RE TM	SPACER, TM SHOCK HEAD
5	12058	2		O RING TESTA AMMORTIZZATORE	O-RING SHOCK HEAD TM
6	12007	1		O RING SCARICO 250/300 M.99/-> O-RING 80cc M. 86/91	O-RING, EXHAUST 250/300 99->
7	F72527	1		TUBO CORPO MONOAMMORTIZ.TM M57	SHOCKBODY TM M57
8	49792	1		VITE TE F/R 10X54 1.25 T.AL08	BOLT, M10X1.25X54 ALU.FRAME08
9	F72529	1		GUIDASTELO MONO TM	HEADSHAFT TM SHOCK ABSORBER
10	72252	1		BOCCOLA SCORRIM. ASTA AMMOR.1812	
11	F04387	1		ANELLO DI TENUTA STELO MONO TM	
12	F48399	1		RALLA SPALL.TO BOCCOLA ST.MONO	
13	F12333	1		O-RING NBR (42.86x3.53)	
14	F72402	1		TAMPONE F.C.ESTENSIONE AMMORT.	
15	F04374	1		PARAPOLVERE AMMORTIZZATORE TM	DUST SEAL TM MONOSHOCK
16	49268	1		SEEGER SB 50 (PER FORI)	SEEGER SB 50
17	F72350	1		COPERCHIO MONOAMM. 250N TM	
18	49944	1		VITE TS 5X12 TORX	
19	F12306	1		O RING 2018-13 CARB.D.32-40 4T	
20	72406	1		VALVOLA COMPRESSIONE MONO TM	COMPRESSION VALVE TM MONOSHOCK
21	49223	1		ANELLO DI ARRESTO SEEGER SB 55	
22	F26610	1		Distanziale interno amm.re sp. 2 mm	
22	F26611	1		Distanziale interno amm.re sp. 3 mm	
22	F26612	1		Distanziale interno amm.re sp. 7 mm	
23	72282	1		BLADDER AMMORTIZZ. TM Ø 55	
24	72281	1		TAPPO BOMBOLETTA MONO TM Ø 55	
25	49681	1		DADO M 10 X 1,25 CH 14 FLANG. AUTOBLOCK	NUT M10x1,25 FLANGED SELF-LOCK
26	F72381	1		VALVOLA GONFIAGGIO BOMBOLETTA	VALVE, SHOCK ABSORBER TM



2T125EN25  
2T 125 ES EN

MONO TM

3

Pos.	Codice	Q.tà	Note	Descrizione	Description
27	F72456	1		STELO AMMORTIZZATORE TM +8mm	SHAFT SHOCK ABSORBER TM +8mm
28	F72405	1		RONDELLA D.12x26x4	
29	F72404	1		RONDELLA D.12x44.5x5	
30	F72372	1		PISTONE AMMORTIZZATORE TM	
31	F12328.1	2		O-RING PIST. AMMORTIZ. 42,5X2,00 FPM70 NERO	
32	F72401	1		ANELLO TENUTA PIST.AMMORT.D.50	OIL SEAL SHOCKABSORBER PIST.D50
33	F49848	1		DADO M12x1,25 - AMMORT.TM	
34	75120	1		PACCO LAMELLE COMPRESSIONE 2T	
35	76120	1		PACCO LAMELLE ESTENSIONE 2T	
36	F72406	1		UGELLO FRENATURA ESTENS.MONOAM	PISTON ROD NEEDLE
37	F72457	1		ASTINA FRENA ESTENS.AMM.TM+8mm	REBOUND ADJUSTER ROD S.A.TM+8
38	F72371	1		PUNTALE PER ASTINA MONO TM STD	
39	12056	1		O RING ASTINA MONOAMMORTIZ. TM	
40	F72403	1		TAMPONE F.C.COMPRESS.AMMORTIZ.	BUMP RUBBER TM SHOCK ABSORBER
41	F72362	1		PIEDINO A FORCH. MONOAMM.TM 4T + 2T/2022	
42	F72368	1		REGISTRO ESTENSIONE AMM.RE TM	
43	F12319	1		O RING RITORNO MONO TM	
44	F16455	1		MOLLA BLOCCAGGIO REGIST.ESTENS	
45	19057	2		SFERA D. 3 mm	
46	F72485	1		BICCHIERE PORTA-MOLLA MONO C.E	
47	F72366	1		FLANGIA PORTA-MOLLA MONOAMM.	
48	F49845	1		ANELLO DI RITEGNO X ALBER.D.60	
49	F72351	1		MOLLA MONOAMM. TM ACC. K=44	SPRING MONOSHOCK TM STEEL K=44
49	F72352	1		MOLLA MONOAMM. TM ACC. K=46	SPRING MONOSHOCK TM STEEL K=46
49	F72353	1		MOLLA MONOAMM. TM ACC. K=48	SPRING MONOSHOCK TM STEEL K=48
49	F72354	1		MOLLA MONOAMM. TM ACC. K=50	SPRING MONOSHOCK TM STEEL K=50
49	F72355	1		MOLLA MONOAMM. TM ACC. K=52	SPRING MONOSHOCK TM STEEL K=52
49	F72398	1		MOLLA MONOAMM. TM ACC. K=54	SPRING MONOSHOCK TM STEEL K=54



2T125EN25  
2T 125 ES EN

MONO TM

3

Pos.	Codice	Q.tà	Note	Descrizione	Description
49	F72399	1		MOLLA MONOAMM. TM ACC. K=56	SPRING MONOSHOCK TM STEEL K=56
49	F72423	1		MOLLA MONOAMM. TM ACC. K=42	SPRING MONOSHOCK TM STEEL K=42
49	F72458	1		MOLLA MONOAMM. TM ACC. K=58	SPRING MONOSHOCK TM STEEL K=58
49	F72459	1		MOLLA MONOAMM. TM ACC. K=60	SPRING MONOSHOCK TM STEEL K=60
49	F72460	1		MOLLA MONOAMM. TM ACC. K=62	SPRING MONOSHOCK TM STEEL K=62
49	F72462	1		MOLLA MONOAMM. TM ACC. K=40	SPRING MONOSHOCK TM STEEL K=40
50	72421	1		GHIERA INF. PREC. MOLLA MONO TM'18 2T/4T	NUT FOR SPRING BOTTOM TM 2S 4S
51	72420	1		GHIERA SUP. PREC. MOLLA MONO TM'18 2T/4T	NUT FOR SPRING TOP TM 2S 4S
52	72089	1		RONDELLA MONO TM 75X60.75 X0.3	WASHER, MONOSHOCK TM 0,3
54	F26548	1		BOCCOLA PROT.CORPO MONOAMM. TM	SHOCK TM BODY PROTECTION
55	F49852	1		ANELLO RITEGNO X ALB. D.54.2	STOP RING SHOCK BODY TM
56	F48398	1		RALLA SPA.GUARN.F04387 MONO TM	
57	72409.19	1		KIT REVISIONE GUIDASTELO MONO TM MY19	TM MONOSHOCK SEAL HEAD REVISION MY19->
58	72422	1		GUIDASTELO MONO TM CPL M. 19->	SHOCK SEAL HEAD ASSY MY19->



2T125EN25  
2T 125 ES EN

CARBURATORE KEIHIN PWK 38  
CARBURETTOR KEIHIN PWK 38

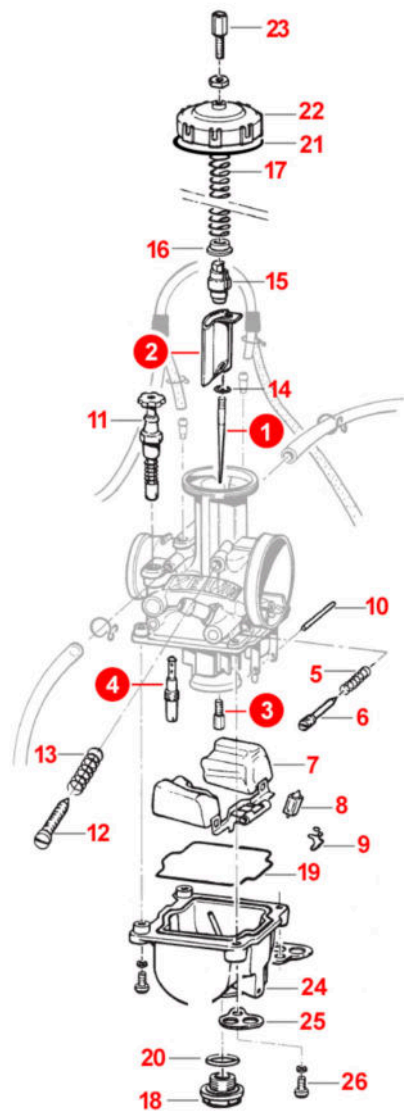



2T125EN25  
2T 125 ES EN

CARBURATORE KEIHIN PWK 38  
CARBURETTOR KEIHIN PWK 38

4

Pos.	Codice	Q.tà	Note	Descrizione	Description
1	D24101.N0ZD	1		SPILO CONICO KEIHIN N0ZD	NEEDLE KEIHIN N0ZD
1	D24101.N0ZE	1		SPILO CONICO KEIHIN N0ZE	NEEDLE KEIHIN N0ZE
1	D24101.N0ZF	1		SPILO CONICO KEIHIN NOZF	NEEDLE KEIHIN NOZF
1	D24101.N0ZG	1		SPILO CONICO KEIHIN NOZG	NEEDLE KEIHIN NOZG
1	D24101.N0ZH	1		SPILO CONICO KEIHIN NOZH	NEEDLE KEIHIN NOZH
1	D24101.N0ZI	1		SPILO CONICO KEIHIN NOZI	NEEDLE KEIHIN NOZI
1	D24101.N1EC	1		SPILO CONICO KEIHIN N1EC	NEEDLE KEIHIN N1EC
1	D24101.N1ED	1		SPILO CONICO KEIHIN N1ED	NEEDLE KEIHIN N1ED
1	D24101.N1EE	1		SPILO CONICO KEIHIN N1EE	NEEDLE KEIHIN N1EE
1	D24101.N1EG	1		SPILO CONICO KEIHIN N1EG	NEEDLE KEIHIN N1EG
1	D24101.N1EH	1		SPILO CONICO KEIHIN N1EH	NEEDLE KEIHIN N1EH
1	D24101.N1EI	1		SPILO CONICO KEIHIN N1EI	NEEDLE KEIHIN N1EI
1	D24101.N1EJ	1		SPILO CONICO KEIHIN N1EJ	NEEDLE KEIHIN N1EJ
1	D24101.N4SC	1		SPILO CONICO KEIHIN N4SC	NEEDLE KEIHIN N4SC
1	D24101.NJWC	1		SPILO CONICO KEIHIN NJWC	
2	D24109	1		VALVOLA GAS KEIHIN PWK 38 - 7	SLIDE VALVE KEIHIN PWK 38 - 7
2	D24109.1	1		VALVOLA GAS KEIHIN PWK 38 6.5	
2	D24109.2	1		VALVOLA GAS KEIHIN PWK 38 - 6	
3	D24100.112	1		GETTO MASSIMO KEIHIN 112	
3	D24100.115	1		GETTO MASSIMO KEIHIN 115	
3	D24100.118	1		GETTO MASSIMO KEIHIN 118	
3	D24100.120	1		GETTO MASSIMO KEIHIN 120	MAIN JET KEIHIN 120
3	D24100.122	1		GETTO MASSIMO KEIHIN 122	MAIN JET KEIHIN 122
3	D24100.125	1		GETTO MASSIMO KEIHIN 125	MAIN JET KEIHIN 125
3	D24100.128	1		GETTO MASSIMO KEIHIN 128	MAIN JET KEIHIN 128
3	D24100.130	1		GETTO MASSIMO KEIHIN 130	MAIN JET KEIHIN 130
3	D24100.132	1		GETTO MASSIMO KEIHIN 132	MAIN JET KEIHIN 132
3	D24100.135	1		GETTO MASSIMO KEIHIN 135	MAIN JET KEIHIN 135





2T125EN25  
2T 125 ES EN

CARBURATORE KEIHIN PWK 38  
CARBURETTOR KEIHIN PWK 38

4

Pos.	Codice	Q.tà	Note	Descrizione	Description
3	D24100.140	1		GETTO MASSIMO KEIHIN 140	
3	D24100.145	1		GETTO MASSIMO KEIHIN 145	
3	D24100.148	1		GETTO MASSIMO KEIHIN 148	
3	D24100.150	1		GETTO MASSIMO KEIHIN 150	MAIN JET KEIHIN 150
3	D24100.152	1		GETTO MASSIMO KEIHIN 152	
3	D24100.155	1		GETTO MASSIMO KEIHIN 155	
3	D24100.158	1		GETTO MASSIMO KEIHIN 158	
3	D24100.160	1		GETTO MASSIMO KEIHIN 160	MAIN JET KEIHIN 160
3	D24100.162	1		GETTO MASSIMO KEIHIN 162	MAIN JET KEIHIN 162
3	D24100.165	1		GETTO MASSIMO KEIHIN 165	MAIN JET KEIHIN 165
3	D24100.168	1		GETTO MASSIMO KEIHIN 168	MAIN JET KEIHIN 168
3	D24100.170	1		GETTO MASSIMO KEIHIN 170	MAIN JET KEIHIN 170
3	D24100.172	1		GETTO MASSIMO KEIHIN 172	MAIN JET KEIHIN 172
3	D24100.175	1		GETTO MASSIMO KEIHIN 175	MAIN JET KEIHIN 175
3	D24100.178	1		GETTO MASSIMO KEIHIN 178	MAIN JET KEIHIN 178
3	D24100.180	1		GETTO MASSIMO KEIHIN 180	MAIN JET KEIHIN 180
3	D24100.182	1		GETTO MASSIMO KEIHIN 182	MAIN JET KEIHIN 182
3	D24100.185	1		GETTO MASSIMO KEIHIN 185	MAIN JET KEIHIN 185
3	D24100.188	1		GETTO MASSIMO KEIHIN 188	MAIN JET KEIHIN 188
3	D24100.190	1		GETTO MASSIMO KEIHIN 190	MAIN JET KEIHIN 190
3	D24100.192	1		GETTO MASSIMO KEIHIN 192	MAIN JET KEIHIN 192
3	D24100.195	1		GETTO MASSIMO KEIHIN 195	MAIN JET KEIHIN 195
3	D24100.198	1		GETTO MASSIMO KEIHIN 198	MAIN JET KEIHIN 198
3	D24100.200	1		GETTO MASSIMO KEIHIN 200	MAIN JET KEIHIN 200
3	D24100.205	1		GETTO MASSIMO KEIHIN 205	MAIN JET KEIHIN 205
3	D24100.210	1		GETTO MASSIMO KEIHIN 210	MAIN JET KEIHIN 210
3	D24100.215	1		GETTO MASSIMO KEIHIN 215	MAIN JET KEIHIN 215
4	D24102.35	1		GETTO MINIMO KEIHIN 35	



2T125EN25  
2T 125 ES EN

CARBURATORE KEIHIN PWK 38  
CARBURETTOR KEIHIN PWK 38

4

Pos.	Codice	Q.tà	Note	Descrizione	Description
4	D24102.38	1		GETTO MINIMO KEIHIN 38	SLOW JET KEIHIN - 38
4	D24102.40	1		GETTO MINIMO KEIHIN 40	SLOW JET KEIHIN - 40
4	D24102.42	1		GETTO MINIMO KEIHIN 42	SLOW JET KEIHIN 42
4	D24102.45	1		GETTO MINIMO KEIHIN 45	SLOW JET KEIHIN 45
4	D24102.48	1		GETTO MINIMO KEIHIN 48	SLOW JET KEIHIN 48
4	D24102.50	1		GETTO MINIMO KEIHIN 50	SLOW JET KEIHIN 50
4	D24102.52	1		GETTO MINIMO KEIHIN 52	SLOW JET KEIHIN 52
4	D24102.55	1		GETTO MINIMO KEIHIN 55	SLOW JET KEIHIN 55
4	D24102.58	1		GETTO MINIMO KEIHIN 58	SLOW JET KEIHIN 58
4	D24102.60	1		GETTO MINIMO KEIHIN 60	SLOW JET KEIHIN 60
5	D24110	1		MOLLA VITE ARIA 4150 KEIHIN	SPRING AIR SCREW 4150 KEIHIN
6	D24121	1		VITE ARIA CARB. KEIHIN	ADJUST SCREW KEIHIN
7	D24124	1		GALLEGGIANTE CARB. KEIHIN	FLOAT BOWL ASSY CARB. KEIHIN
8	D24113	1		VALVOLA AD AGO PWK Keihin 3.8	FLOAT VALVE KEIHIN PWK
9	D24114	1		CLIP X AGO VALVOLA BENZ.4220	CLIP, FLOAT VALVE KEIHIN
10	D24103	1		PERNO GALLEGGIANTE KEIHIN	PIN, KEIHIN CARB. FLOAT
11	D24112	1		DISPOSITIVO ARIA KEIHIN REDCAP	CHOKE KNOB ASSY KEIHIN REDCAP
12	D24104	1		VITE DEL MINIMO KEIHIN	IDLE ADJUSTER KEIHIN
13	D24105	1		MOLLA VITE MINIMO KEIHIN	SPRING IDLE ADJUSTER KEIHIN
14	D24111	1		SEEGER SPILLO KEIHIN 41000	CLIP, NEEDLE KEIHIN
15	D24119	1		ATTACCO CAVO GAS KEIHIN	THROTTLE CABLE HOLDER KEIHIN
16	D24118	1		COLLARINO KEIHIN 38	COLLAR KEIHIN 38
17	D24117	1		MOLLA VALVOLA KEIHIN 38	SPRING CARB. KEIHIN 38
18	D24115	1		TAPPO VASCHETTA KEIHIN 4300 16162-ND4-7511-M1	CAP, KEIHIN BOWL 4300
19	D24127	1		GUARN. VASCHETTA Keihin	GASKET, FLOAT CHAMBER KEIHIN
20	D24108	1		O-RING TAPPO VASCH. KEIHIN OR NBR 123 (2.62x17.86)	O RING, CAP FLOAT CHAMBER KEI.
21	D24123	1		GUARN. COPERCHIO CARB. KEIHIN	GASKET, TOP COVER KEIHIN
22	D24122	1		COPERCHIO CARBURATORE KEIHIN PWK	



2T125EN25  
2T 125 ES EN

CARBURATORE KEIHIN PWK 38  
CARBURETTOR KEIHIN PWK 38

4

Pos.	Codice	Q.tà	Note	Descrizione	Description
23	D24131	1		VITE TENDIFILO Keihin	SCREW WIRE CARB KEIHIN
24	D24133	1		VASCHETTA KEIHIN PWK 38	FLOAT BOWL KEIHIN PWK 38
25	D24128	1		PASSATUBO Keihin	
26	D24135	1		VITE VASCHETTA KEIHIN PWK 38	