



---

USES AND  
RACOMMENDS



[www.tmracing.it](http://www.tmracing.it)

---

TM Racing SpA - Via Fano, 6  
61122 Pesaro - ITALY  
Phone: +39 0721 25113

## 4T300FIMX25

4T 300 Fi MX

4S 300 Fi MX

29/10/2024



## INFORMAZIONI GENERALI

Il presente catalogo serve per richiedere con esattezza le parti di ricambio.

Nelle ordinazioni indicare:

**1) Il numero di matricola del Telaio** che è stampigliato sul lato destro del canotto di sterzo. Nei modelli EN, SMR, SMR il numero di matricola è riportato anche su una targhetta posta sul lato sinistro (Vedi foto).

**2) il numero di serie del Motore.** E' posto sulla sinistra del motore tra la leva cambio e i coperchio accensione (Vedi foto).

**3) Il codice dei particolari** seguito dalla descrizione.

**4) Il colore per i pezzi verniciati o comunque colorati.**

Le indicazioni destra e sinistra si riferiscono ai lati del veicolo rispetto al senso di marcia.

Foto e disegni sono solo a scopo informativo e potrebbero non corrispondere esattamente alle caratteristiche dei prodotti.

## GENERAL INFORMATION

The present spare parts catalogue enables one to order exactly the right spare part.

When ordering specify:

**1) The frame serial number.** It is embossed on the right side of the steering metal tube. In the EN, SMR and SMR models, the serial number is also stated on a plate positioned on the left hand side (See photo).

**2) The engine serial number.** It is located on the left side of the engine between the gear lever and the ignition cover (See photo).

**3) The part's code number** followed but its description.

**4) Indicate colour** for painted or colored parts.

References to right and left apply to the vehicle in terms of its direction of movement.

Photos and drawings are for informational purposes only and may not exactly match the characteristics of the products.

## NOTE – LEGENDA

**MY**

NOVITA' INTRODOTTA DIFFERENTE O NON PRESENTE NEL MODELLO DELL'ANNO PRECEDENTE

*PART DIFFERENT OR NOT PRESENT IN THE REVIOUS YEAR MODEL*

**5M**

MOTORE CON CAMBIO A 5 MARCE  
ENGINE WITH 5 GEARS SPEED

**6M**

MOTORE CON CAMBIO A 6 MARCE  
ENGINE WITH 6 GEARS SPEED

**KS**

MOTORE CON SOLO KICK STARTER  
ENGINE WITH KICK STARTER ONLY

**ES**

MOTORE CON AVVIAMENTO ELETTRICO  
ENGINE WITH ELECTRIC STARTER

**X**

RICAMBIO NON DISPONIBILE ALLA VENDITA  
PART CAN NOT BE SOLD SEPARATELY

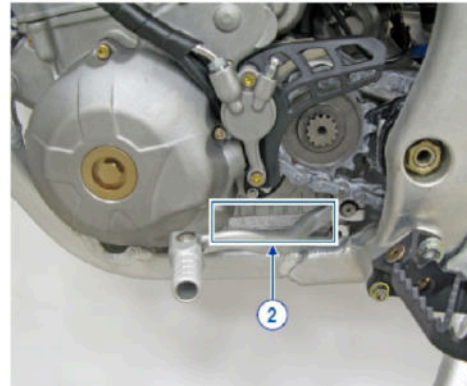
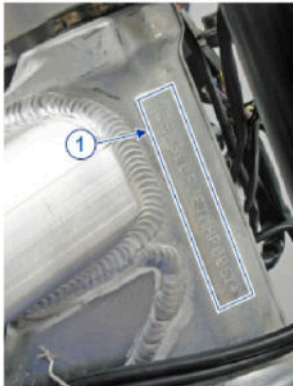

Le illustrazioni riportate in questo manuale sono fornite solo come riferimento e possono variare dal prodotto effettivo,

Dati indicativi soggetti a modifiche senza impegno di preavviso.

The illustrations in this manual are for reference only and may vary from the actual product.

All data are subject to modification without prior notice.



**4T300FIMX25**

**4T 300 Fi MX - 4S 300 Fi MX**

**SOMMARIO**

**TABLE OF CONTENTS**

MANUBRIO - HANDLEBAR.....	5
FRENO ANTERIORE - FRONT BRAKE.....	7
FORCELLA - FORNT FORK.....	9
RUOTA ANTERIORE MX - FRONT WHEEL.....	12
ELETTROVENTOLA - ELECTRIC FAN.....	14
RADIATORI - RADIATORS.....	16
AIRBOX.....	18
TELAIO - FRAME.....	20
PLASTICHE E SELLA - PLASTIC AND SEAT.....	23
SERBATOIO - FUEL TANK.....	26
FORCELLONE - SWINGARM.....	28
LEVERAGGI - LINKAGE.....	30
RUOTA POSTERIORE 19x2.15 - REAR WHEEL 19x2.15.....	32
FRENO POSTERIORE - REAR BRAKE.....	35
SCARICO - EXHAUST SYSTEM.....	38
CABLAGGI - EXHAUST.....	40
KIT ADESIVI MX.....	42
CILINDRO - PISTONE - CYLINDER - PISTON.....	44
TESTA - HEAD.....	46
ALBERO MOTORE - CRANKSHAFT.....	49
DISTRIBUZIONE - DISTRIBUTION.....	51
LUBRIFICAZIONE - LUBRICATION.....	54



**4T300FIMX25**  
**4T 300 Fi MX - 4S 300 Fi MX**

**SOMMARIO**  
**TABLE OF CONTENTS**

CARTER MOTORE - CLUTCH CASE.....	57
FRIZIONE - CLUTCH.....	59
COMANDO CAMBIO - GEARSHIFT MECHANISM.....	62
CAMBIO - GEAR BOX.....	65
CENTRIFUGATORE AVVIAMENTO.....	68
ACCENSIONE ES (4 FORI).....	70
MONO TM 4T MY 2020.....	73
CORPO FARFALLATO - THROTTLE BODY.....	77



4T300FIMX25  
4T 300 Fi MX - 4S 300 Fi MX

MANUBRIO  
HANDLEBAR

1

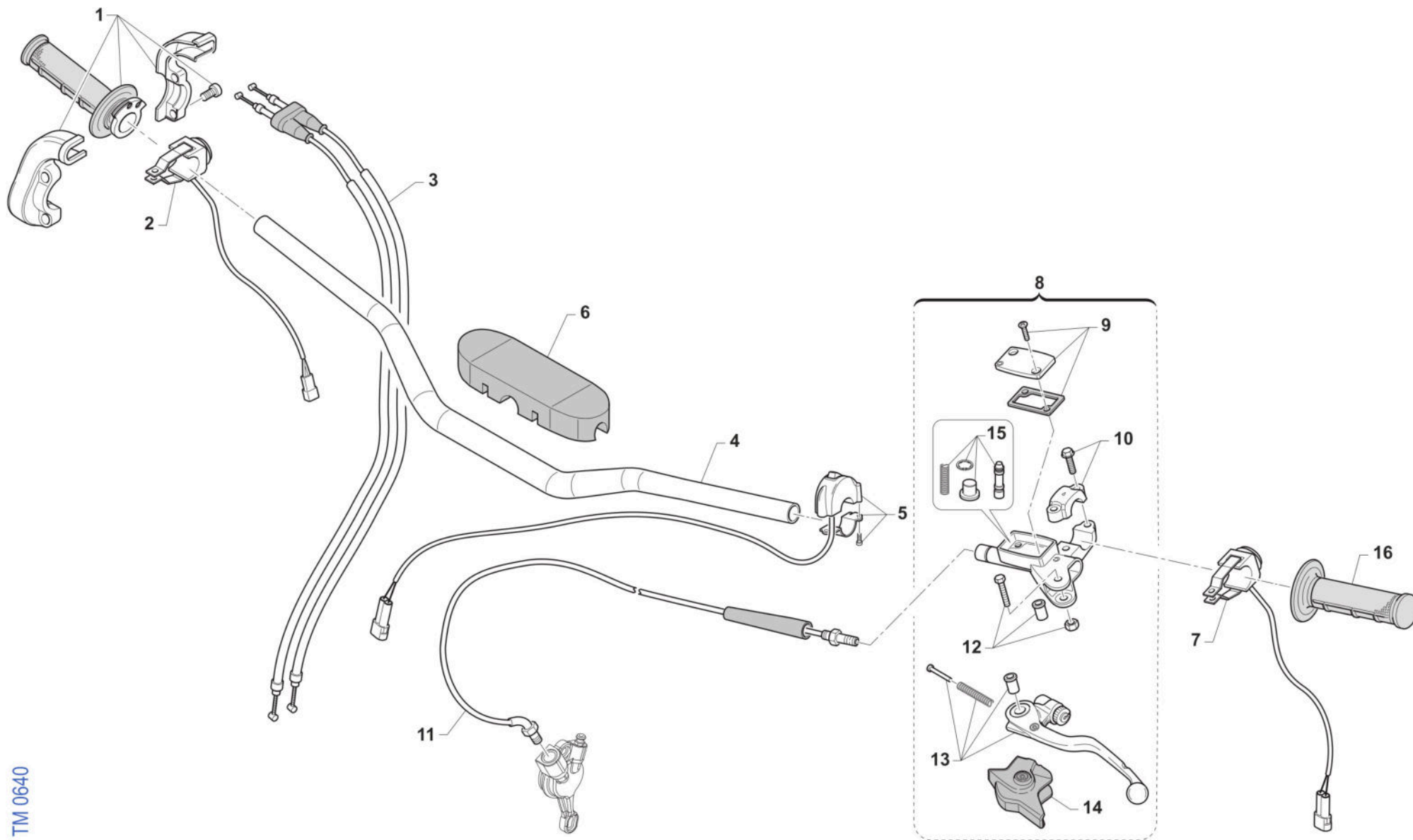

TM 0640



4T300FIMX25  
4T 300 Fi MX - 4S 300 Fi MX

MANUBRIO  
HANDLEBAR

1

Pos.	Codice	Q.tà	Note	Descrizione	Description
1	F64300	1		COMANDO GAS DOMINO 4T	THROTTLE ASSY DOMINO 4S
2	68244	1		PULSANTE AVVIAMENTO MOTO ES MY19->	BUTTON, START BIKE E.S. M. 19->
3	F64322	1		CAVO GAS 4T INIEZIONE M.10->	THROTTLE CABLE 4S Fi M.10/->
4	64085	1		MANUBRIO TM RACING 9012 TL	
5	68029	1		COMMUTATORE MAPPE CDI M.DOMINO	SWITCH, ECU MAP CONTROL DOMINO
6	64078.1	1		PARACOLPI MANUBRIO TM 2013 NR	PROTECTION FOR HANDLEBAR TM BLACK
7	F68189	1		PULSANTE DI MASSA MX Fi ASAHI	KILL BUTTON Fi
8	69360	1		POMPA FRIZIONE PS 9/17.7 BREMBO	PUMP, CLUTCH PS 9/17.7 BREMBO
9	64266	1		COPERCH./MEMBRAN.P.FRIZ.BREMBO 69360	
10	64249	1		CAVALLOTTO POMPA FRIZIONE BREM	HOLDER CLUTCH MASTER CY.BREMBO
11	F35606	1		TUBO FRIZIONE IDR. 250Fi MX 2018	CLUTCH HOSE, 4S TWIN
12	64245	1		PERNO LEVA POMPA FRIZ. BREMBO	PIN
13	64241	1		LEVA FRIZIONE BREMBO RICAMBIO	LEVER, CLUTCH BREMBO
14	64238	1		PARAPOLVERE POMPA FRIZIONE BR.	DUST SEAL,CLUTCH MASTER CYL.BR
15	64265	1		FLOTTANTE POMPA FRIZ. BREMBO 69360 9/17	
16	64087	1		MANOPOLE COPPIA CIRCUIT IV (AZZURRO)	
16	67418	1		MANOPOLE JUPITER MA042-213 COLORE NERO\GRIGIO COPPIA	



4T300FIMX25  
4T 300 Fi MX - 4S 300 Fi MX

FRENO ANTERIORE  
FRONT BRAKE

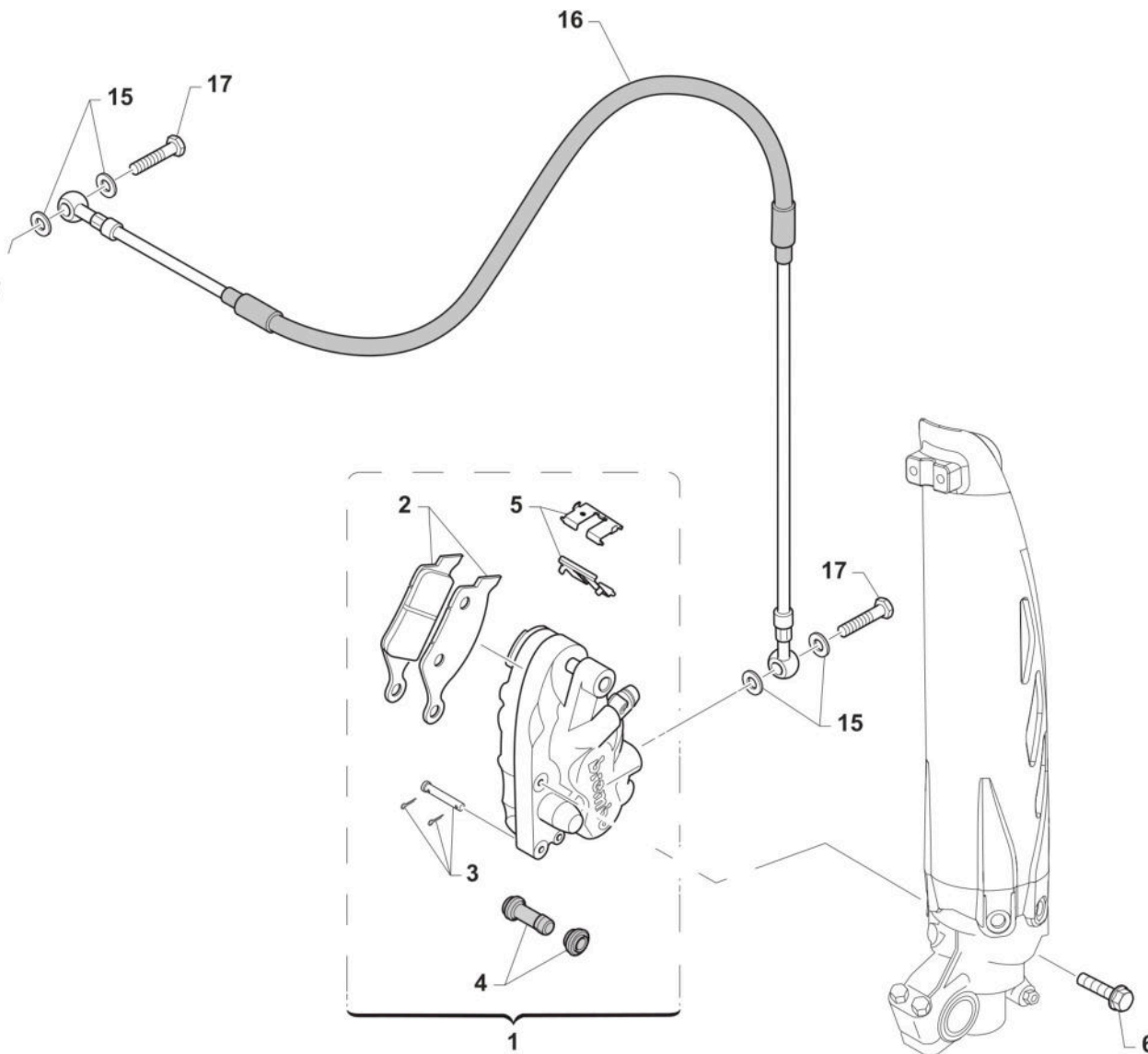
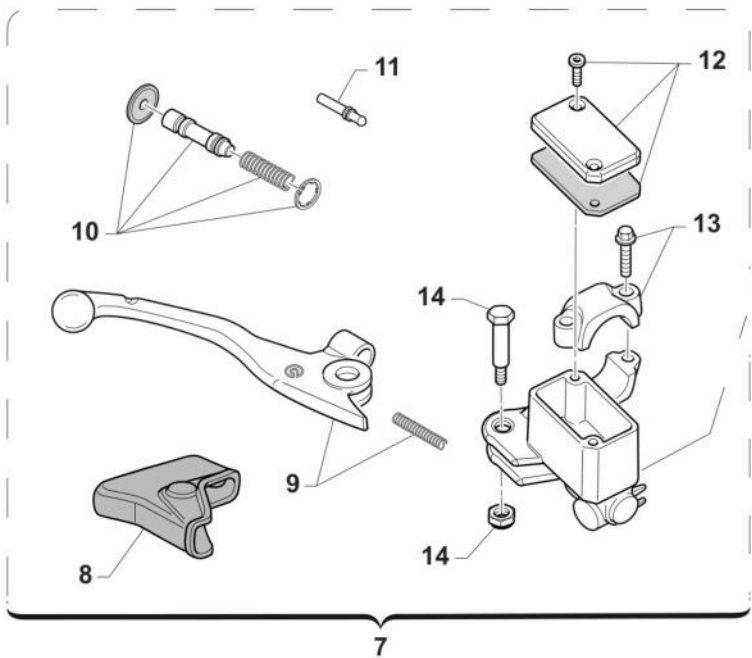

TM0125



4T300FIMX25  
4T 300 Fi MX - 4S 300 Fi MX

FRENO ANTERIORE  
FRONT BRAKE

2

Pos.	Codice	Q.tà	Note	Descrizione	Description
1	69222	1		PINZA FRENO ANTERIORE KYB PF2	CALIPER, FRONT BRAKE XKYB PF2
2	69107	1		PASTIGLIE ANTE. M.92/14 BREMBO	PAD KIT, FR BRAKE BREMBO 92/->
2	69117	1		PASTIGLIE ANT.M.92/11 SINT.TOS	PADS, FRONT BRAKE 92->11 SINT.
3	69274	1		PERNO PINZA ANT. 69222	PIN, BRAKE PADS
4	69113	1		CUFFIE PINZA ANT/POST 92/98	COVER, RUBBER CALIPER 92/98
5	69273	1		LAMIERINO PINZA 69222	RETAINER BRAKE PADS 69222
6	49365	2		VITE TE F/R 8X35 Ch.10	BOLT 8X35 T.10mm
7	69248	1		POMPA FRENO ANT PS10/16 BREMBO (opt.JUNIOR)	FRONT MASTER CYLINDER PS 10/16 BREMBO
8	69363	1		CAPPUCCIO POMPA FRENO ANT PS10/16	RUBBER FRONT MASTER CYLINDER BREMBO
9	69357	1		LEVA FRENO ANT BR. X 69248	BRAKE FRONT LEVER BREMBO X 69248
10	69358	1		KIT FLOTTANTE POMPA FREN.69248	CYLINDER AND RUBBER KIT 69248
11	69364	1		PUNTALINO POMPA FRENO ANT PS10/16	PUSH ROD
12	69368	1		TAPPO POMPA FRENO BREMBO 69248	CAP
13	69362	1		CAVALLOTTO POMPA FRENO ANT PS10/16	HOLDER
14	69365	1		PERNO LEVA POMPA FRENO ANT PS10/16	PIN, LEVER
15	69034	4		RONDELLA X BULLONE FREN B22001	WASHER B22001, BRAKE HOSE
16	69060.14	1		TUBO FRENO ANT MX 01/-> WHITE	HOSE,FRONT BRAKE MX M.01 WHITE
17	69093	2		BULLONE 10X1 TUBO FRENO BREMBO 03	HOLLOW SCREW M10X1 BREMBO BR.





4T300FIMX25  
4T 300 Fi MX - 4S 300 Fi MX

FORCELLA  
FORNT FORK

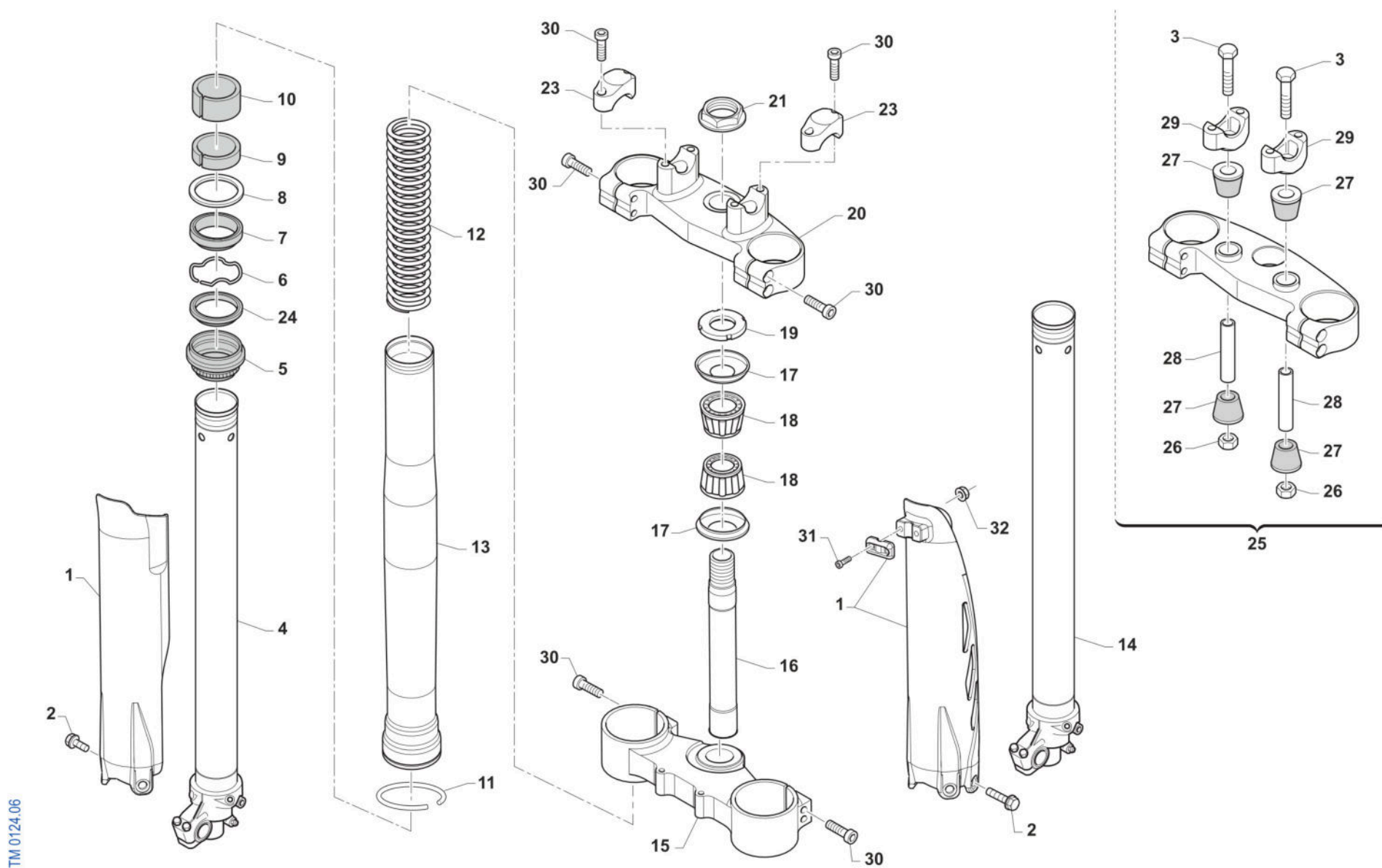

TM 0124.06



4T300FIMX25  
4T 300 Fi MX - 4S 300 Fi MX

FORCELLA  
FORNT FORK

3

Pos.	Codice	Q.tà	Note	Descrizione	Description
1	67471	1		PROTEZ.KIT FORC.USD QUANTUM 2025	
2	49571	6		VITE TBCE 6 x 7 PROT. FORCELLA	BOLT TBCE 6x7
3	49582	2		VITE TE 10X65 UNI 5737	SCREW EH 10X65
4	72568	1		INNER TUBE COMP RIGHT	INNER TUBE COMP RIGHT
5	72502	2		PARAPOLVERE FORCELLA KYB 48 mm	DUST SEAL KYB FORK 48 mm
6	72525	2		SNAP RING OIL SEAL KYB 48 MM	SNAP RING OIL SEAL KYB 48 MM
7	72501	2		PARAOLIO FORCELLA KYB 48 mm	OIL SEAL KYB FORK 48 mm
8	72526	2		WASHER NEXT TO OIL SEAL KYB 48	WASHER NEXT TO OIL SEAL KYB 48
9	72504	2		SLIDE METAL KYB 48 mm	SLIDE METAL KYB 48
10	72503	2		PISTON METAL KYB 48 mm	PISTON METAL KYB 48
11	72530	2		SNAP RING OUTERTUBE KYB 48 MM	SNAP RING OUTERTUBE KYB 48 MM
12	F72445	2		MOLLA FORCELLA KAYABA 48 K=4.0	SPRING, FORKS KYB 48 K=4.0
12	F72446	2		MOLLA FORCELLA KAYABA 48 K=4.2	SPRING, FORKS KYB 48 K=4.2
12	F72447	2		MOLLA FORCELLA KAYABA 48 K=4.3	SPRING, KYB FORK K 4.3
12	F72448	2		MOLLA FORCELLA KAYABA 48 K=4.4	SPRING, FORKS KYB 48 K=4.4
12	F72449	2		MOLLA FORCELLA KAYABA 48 K=4.6	SPRING, FORKS KYB 48 K=4.6
13	72567.1	2		OUTER TUBE COMP (FODERO) COL. ORO Kashima Gold	OUTER TUBE COMP, GOLD
14	72569	1		INNER TUBE COMP LEFT	INNER TUBE COMP LEFT
15	72000.101	1		PIASTRA INF. KYB 48,22	
15	72000.72	1		PIASTRA INF. KYB 48,23	BOTTOM TRIPLE CLAMP KYB 48,23
16	72007.98	1		CANOTTO STERZO CROSS M. 98/->	STEERING STEM, MX M.98/->
17	72002.02	2		PROTEZIONE CUSC/CANOTTO STERZO M. 02 ->	DUST SEAL, STEERING STEM 02/->
18	03070	2		CUSCINETTO CONICO STERZO 02/->	BUSH, STEERING M. 02/->
19	72008.98	1		GHIERA STERZO FORC.MOTO 98/04	NUT, STEERING BEARING
20	72000.100	1		PIASTRA SUP. KYB 48,22	
20	72000.71	1		PIASTRA SUP. KYB 48,23	BOTTOM TRIPLE CLAMP KYB 48,23
21	49080	1		DADO CANOTTO STERZO 98/-> ALL	NUT, STEERING STEM ALUM 98/->
23	72036.11	2		CAVALLOTTO SUP.M.11 SILVER	UPPER HANDLEBAR M.11 SILVER



4T300FIMX25  
4T 300 Fi MX - 4S 300 Fi MX

FORCELLA  
FORNT FORK

3

Pos.	Codice	Q.tà	Note	Descrizione	Description
24	72341	2		SCRAPER FORC.KYB R.DEPT	SCRAPER
25	72000.109	1		PIASTRA SUP. KYB 48,22 SB CPL	
25	72000.78	1		PIASTRA SUP. KYB 48,23 SB CPL	TOP TRIPLE CLAMP SB KYB 48,23
26	49646	2		DADO M10 BASSO AUTOBLOCCANTE	NUT, M10 LOW SELF-LOCKING
27	21036	4		GOMMINO CAVAL. ANTIVIB.MANUBRIO MY 05->	RUBBER, HANDLEBAR 05/->
28	26106	2		TUBETTO CAV.ANT.VIB.12X45X10	BUSH, RUBBER, TRIPLE CLAMP
29	72037.11	2		CAVALLOTTO INF. 11 RP SB SILVER	LOWER HANDLEBAR, CNC S.B. M11
30	49502	8		VITE TCEI 8X30	BOLT TCEI 8X30
31	49474	2		VITE TCEI 5X16 UNI 5931	BOLT TCEI 5X16
32	49629	2		DADO M 5 ALTO AUTOBLOCCANTE	NUT 5mm, HIGHT SELF-LOCKING



4T300FIMX25  
4T 300 Fi MX - 4S 300 Fi MX

RUOTA ANTERIORE MX  
FRONT WHEEL

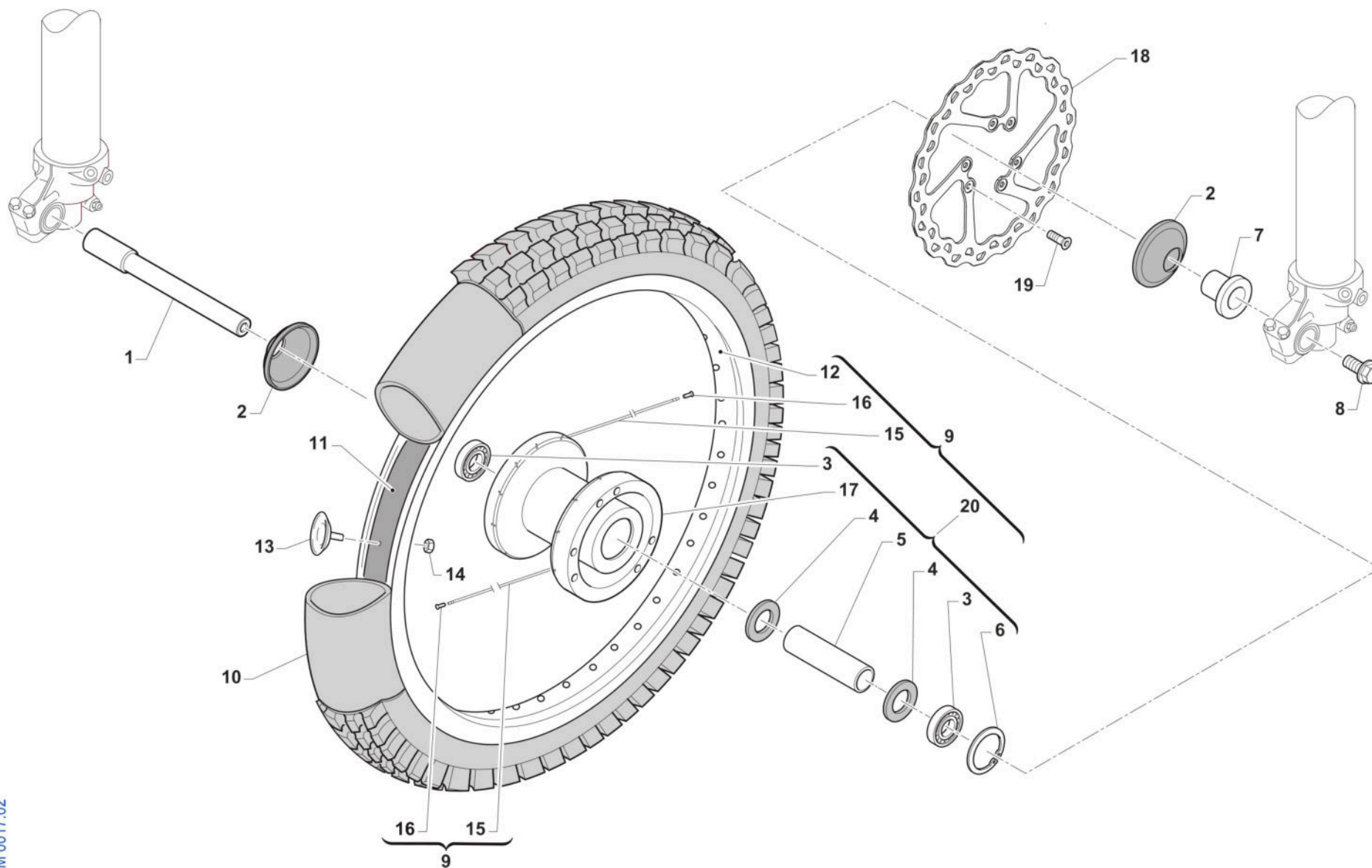

TM 0017.02



4T300FIMX25  
4T 300 Fi MX - 4S 300 Fi MX

RUOTA ANTERIORE MX  
FRONT WHEEL

4

Pos.	Codice	Q.tà	Note	Descrizione	Description
1	74044	1		PERNO RUOTA ANT MA50 07/->	AXLE, FR WHEEL MA50 07/->
2	69998	2		PARAPOLVERE RUOTA ANT. MARZ. KYB 07->	DUST SEAL, FR WHEEL MA50 07/->
3	03071	2		CUSCINETTO RUOTA ANTER. + POSTER.	BUSH, FRONT WHEEL MA50 61905
4	70165	2		RONDELLA GOMMA 42X29X3 D.I.ANT	WASHER, RUBBER 42x29x3
5	70167	1		DIST.INT.R.ANT. MARZOCCHI 07	SPACER INTER.FRONT WHEEL MA.7
6	49250	1		SEEGER I 42 RP 94/96 ANT MARZ.50	CIRCLIP D.42 - REAR WHEEL
7	70166	1		BOCCOLA RUOTA ANT MA50 07/->	SPACER, FR WHEEL MA50 07/->
8	49077	1		DADO PERNO RUOTA ANT M.K.07->	NUT, FR AXLE MA50 M.07/->
9	70191	1		CERCHIO ANT. CPL 21x1.60 MA50/KYB48 BLU	RIM, FRONT MX ASSY 21x1.60 MY10->
10	80150	1		CAMERA ARIA ANTERIORE 21	TUBE, TYRE 21
11	70032	1		FLAP RUOTA ANTERIORE 21	FLAP FRONT WHEEL 21
12	70050	1		CERCHIO ANT 21x1.60 TAKASAGO BLU	FRONT RIM 1.60x21 Takasago
13	70030.1	1		FERMA COPERTURA RUOTA ANTER. 1.60	STOPPER 1.60
14	49640	1		DADO M 8 FLANGIATO CHIAVE 12	NUT 8mm, FLANGE
15	70246	36		RAGGIO R.ANT.4.0/3.1/4.0 X 230	SPOKE FR.WHEEL 4/3.1/4 X 230
16	70062	36		NIPPLO ACCIAIO 4	SPOKE NIPPLE 4 mm
17	70315	1		MOZZO ANT VMX MA50/KYB EN/MX R4 NUDO	
18	69389	1		DISCO FRENO ANTERIORE 269X3 TM	
19	49370	6		VITE TE F/R 6X12	BOLT 6X12
20	70188	1		MOZZO ANT MA50/KYB EN/MX R4 CPL	FRONT HUB MARZ. 2010 --> ASSY



4T300FIMX25  
4T 300 Fi MX - 4S 300 Fi MX

ELETTOVENTOLA  
ELECTRIC FAN

5

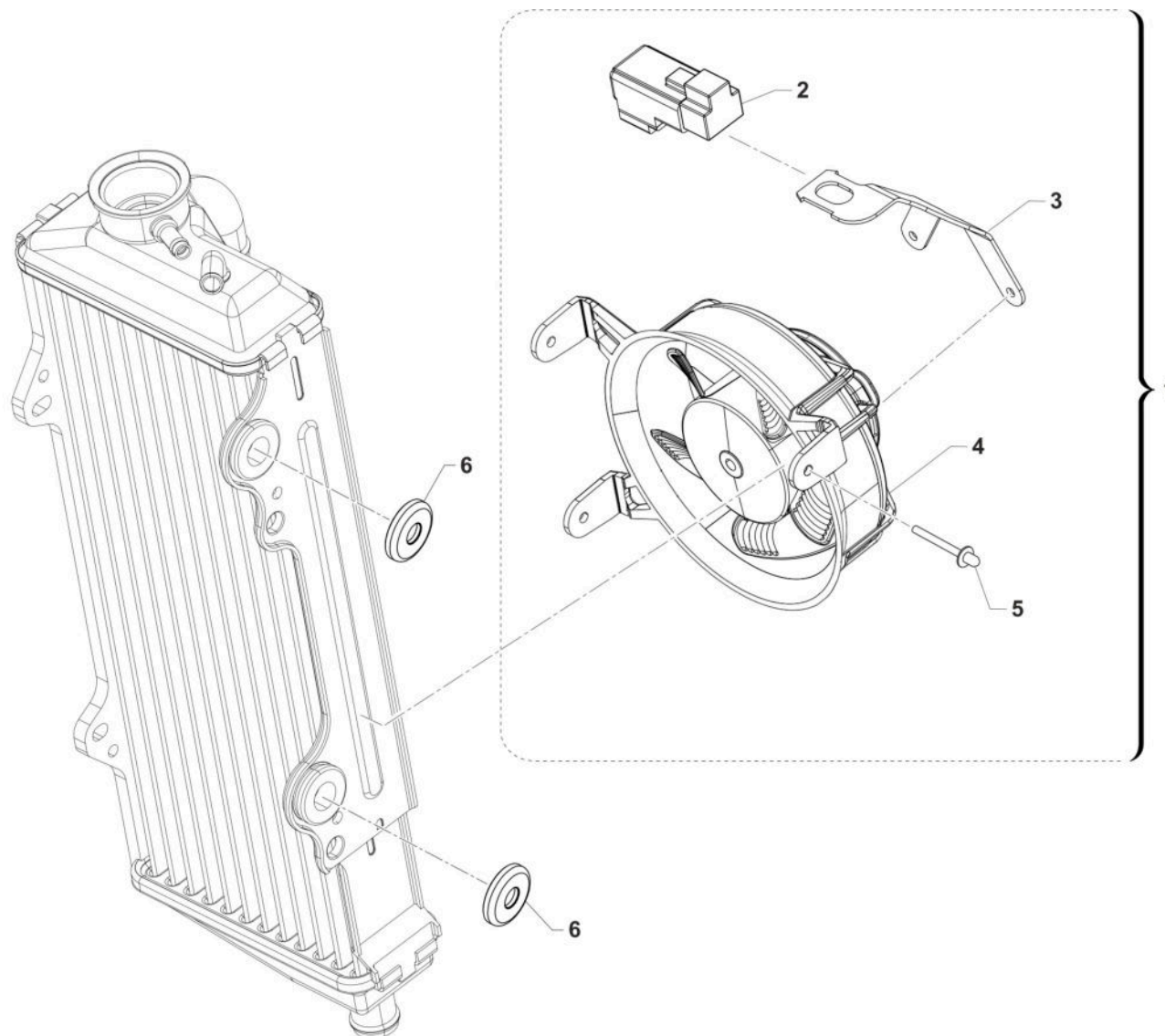

0636.02



4T300FIMX25  
4T 300 Fi MX - 4S 300 Fi MX

ELETTROVENTOLA  
ELECTRIC FAN

5

Pos.	Codice	Q.tà	Note	Descrizione	Description
1	23104	1		ELETTROVENTOLA Ø101 + CONV. MY24 COMPLETA(23103 + 26235 + F68212)	
2	F68212	1		RELAY AVV. ELETTRICO PAN. M2015->	RELAY EL. STARTER M.-> 15
3	26235	1		PIASTRINO FISSAGGIO RELE' SU ELETTROVENTOLA	
4	23103	1		ELETTROVENTOLA Ø101 + CONV. MY24 CABLATA	
5	49807.1	3		RIVETTO ALL. A STRAPPO 4 X10	RIVET 4X10
6	48265	2		DISTANZIALE RADIATORE 4T CON ELETTROVENTOLA	



4T300FIMX25  
4T 300 Fi MX - 4S 300 Fi MX

RADIATORI  
RADIATORS

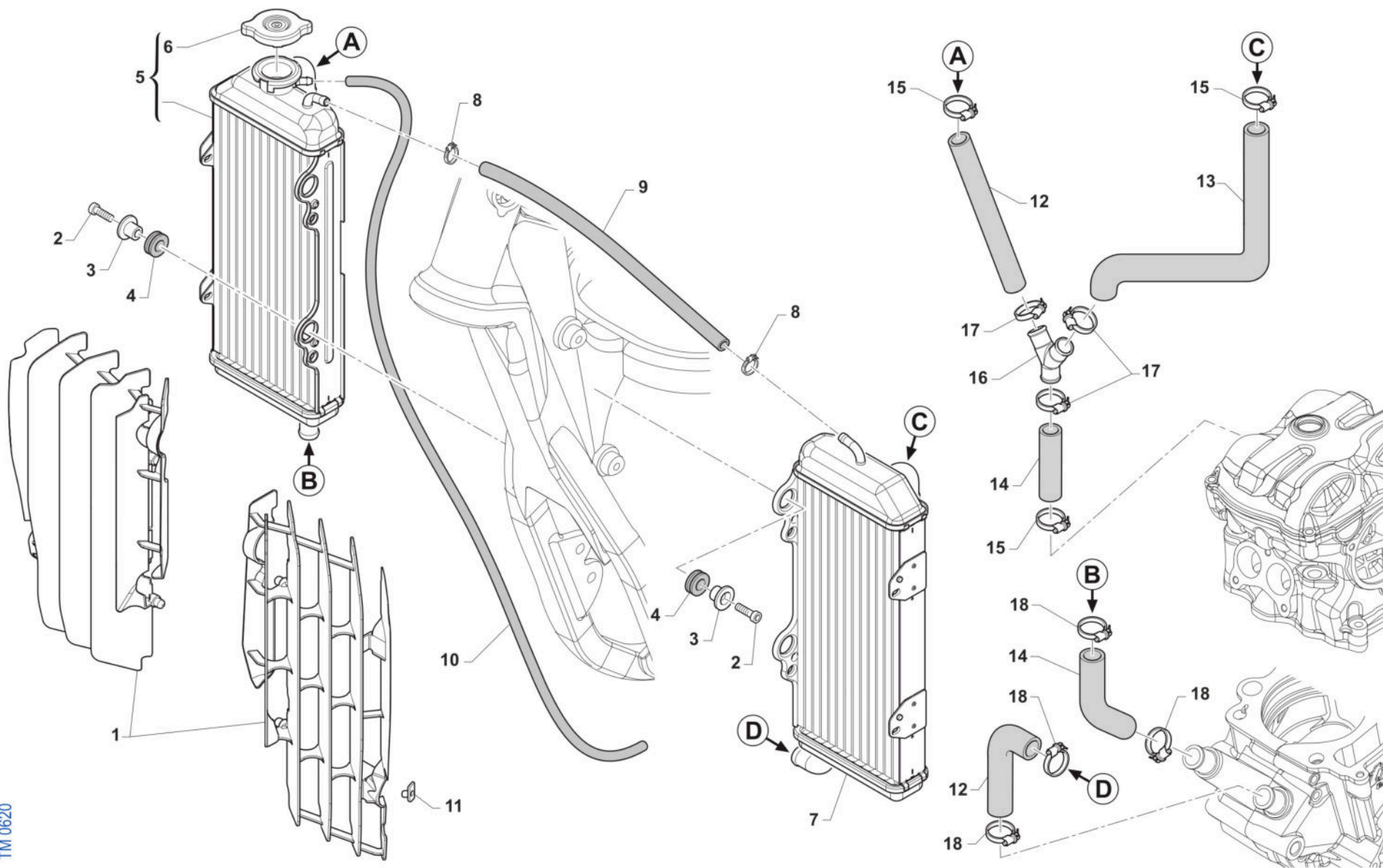

TM 0620





4T300FIMX25  
4T 300 Fi MX - 4S 300 Fi MX

RADIATORI  
RADIATORS

5

Pos.	Codice	Q.tà	Note	Descrizione	Description
1	F23330	1		KIT PROTEZ. RAD. TM MY 12/23 CPL NERO	RADIATOR PROTECTION GRILLE MY 2012 - BLACK
2	49482	4		VITE TCEI 6X14 UNI 5931	BOLT TCEI 6X14
3	26064	4		BOCCOLA RADIATORE MY 02 / 06 ->	BUSH, RADIATOR M.02/06
4	21102	4		GOMMINO ANTIV.RADIAT.SILENZ. MY 94->	RUBBER, GROMMET RADIATOR and SILENC.
5	23083	1		RADIATORE 4T DX LUNGO MY2022 FA L.TAP.(passaggio scarico)	
6	23062	1		TAPPO RADIATORE 1,8 BASSO(PER RADIATORE 23065)	RADIATOR CAP 1,8
7	23084	1		RADIATORE 2T+4T SX LUNGO MY2022 FA	
8	51001	2		FASCETTA 07/11 mm	CLAMP 07/11 mm
9	67028	1		TUBO HYDRO' ECO 6 X 12	
10	67170	1		TUBO COPOLAN GRIGIO 5x9 mm	HOSE, COPOLAN GREY 5x9 mm
11	49801	2		PRESTOLA RADIATORE M6 70117G	RANGE CHANGE MET.NUT M6 70117G
12	F21413.1	1		MANICOTTO ACQUA RADIATORE 05->	WATER HOSE RADIATOR M.2005
13	F21448	1		MANICOTTO ACQUA RADIATORE SX 4T MY22	
14	21023	1		MANICOTTO ACQUA RADIATORE ML	WATER HOSE RADIATOR ML
15	51062	3		FASCETTA A COLLARE DIAM.22 ZN	CLIP, WATER HOSE, d.22 ZN
16	F21439	1		Manicotto metallico acqua ad Y CNC	JOINT, WATER HOSE TWIN
17	F51115	3		FASCETTA OETIKER 25.6	
18	51036	4		FASCETTA A COLLARE DIAM.24 ZN	CLIP, WATER HOSE, d.24 ZN

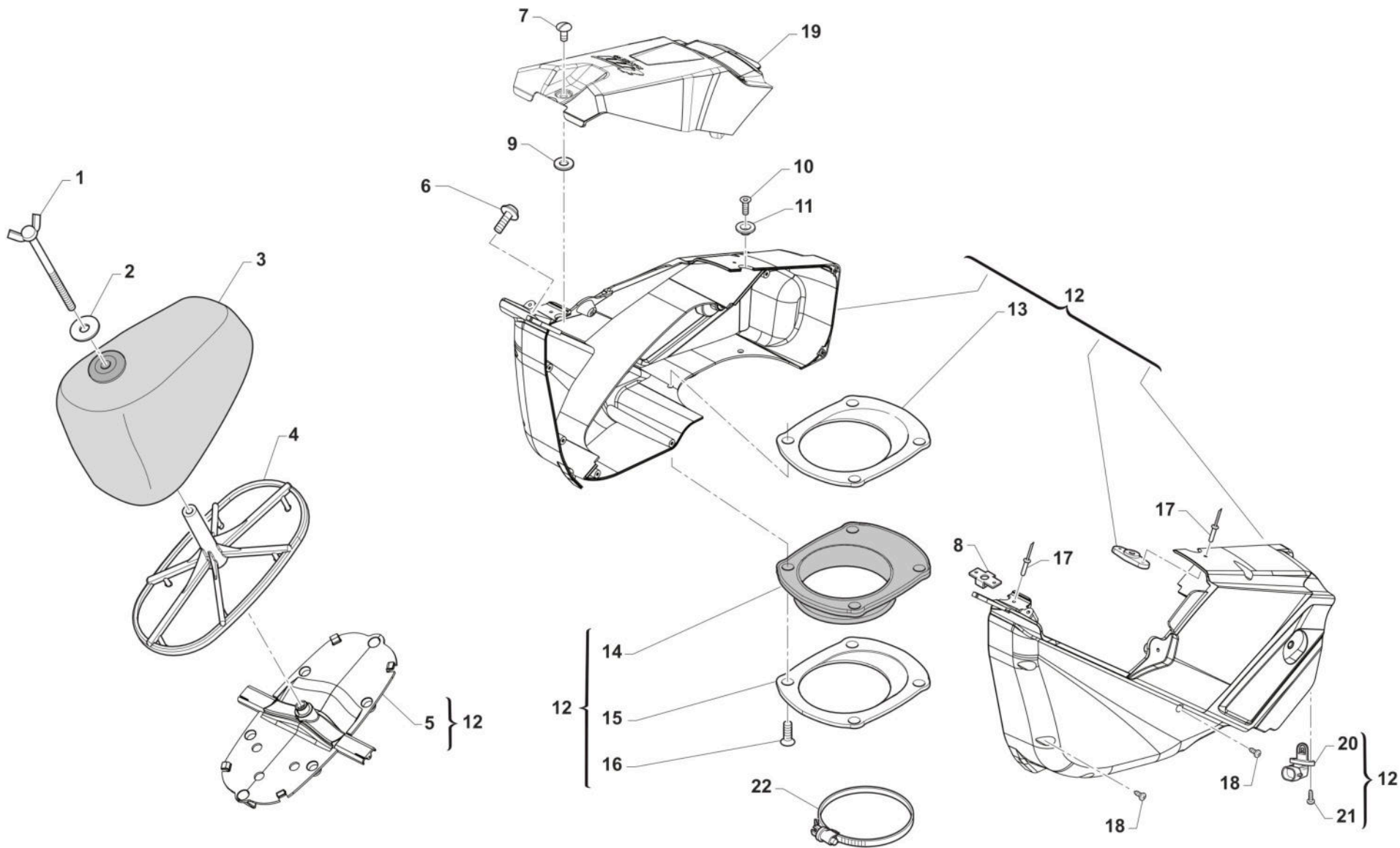



**4T300FIMX25**  
**4T 300 Fi MX - 4S 300 Fi MX**

**AIRBOX**

Pos.	Codice	Q.tà	Note	Descrizione	Description
1	49418	1		GALLETTO C/PERNO FILTRO 6x102	SPECIAL BOLT AIR FILTER M6X102
3	66071	1		FILTRO ARIA 4T MY22 PACKED	AIR FILTER FS PACKED MY22->
4	F66521.22	1		GABBIA FILTRO 4T MY22	CAGE, AIR FILTER FS MY22->
5	F67202	1		STAFFA FISSAGGIO FILTRO MOTO 4T MY22	
6	F49822	1		VITE ES.FLANG.M6X12 T.AL.M08	BOLT, 6X12 AL. FRAME M.08->
7	49925	1		SPINOTTO D8-316-110-190 CORTO	PIN D8-316-110-190 SHORT
8	49924	1		RICETTACOLO D8-336-400-121	PIN D8-336-400-121
9	49923	1		RONDELLA D8-326-100-040	WASHER D8-326-100-040
10	49404	1		VITE TSEI 6X16	BOLT TSEI 6x16
11	26083	1		BOCCOLA FISS.SELLA/SERBAT. M08	BUSH, FIX SEAT / TANK M.08->
12	F67166.22	1		AIRBOX 4T TWIN MY22/23 + 450 MX 22/23 CPL	
13	F67139	1		FLANGIA CUFFIA C.FILT.4T M15 I INTERNA	FLANGE, INTERNAL
14	F66520	1		CUFFIA CASSA FILTRO 4T 2015	AIRBOOT, 4S MY15
15	F67139.1	1		FLANGIA CUFFIA C.FILT.4T M15 E ESTERNA	FLANGE, EXTERNAL
16	49402	4		VITE TSEI 5X20	BOLT TSEI 5X20
17	49888	4		RIVETTO ACC. 3 X12	RIVET 3X12
18	49872	9		VITE TMT+PZ 3X20 PER PLASTICA	SCREW 3X20
19	67415	1		COPERCHIO CASSA FILTRO MOTO 4T MY22-> GRIGIO (MY24)	
19	F67205	1		COPERCHIO CASSA FILTRO MOTO 4T MY22-> BIANCO	
20	F08004	1		SENSORE TEMP. ARIA	SENSOR, AIR TEMPERATURE ATS05
21	49304	2		VITE T.C. 3X12	BOLT
22	51006	1		FASCETTA 92/112	CLAMP 92/112



4T300FIMX25  
4T 300 Fi MX - 4S 300 Fi MX

TELAIO  
FRAME

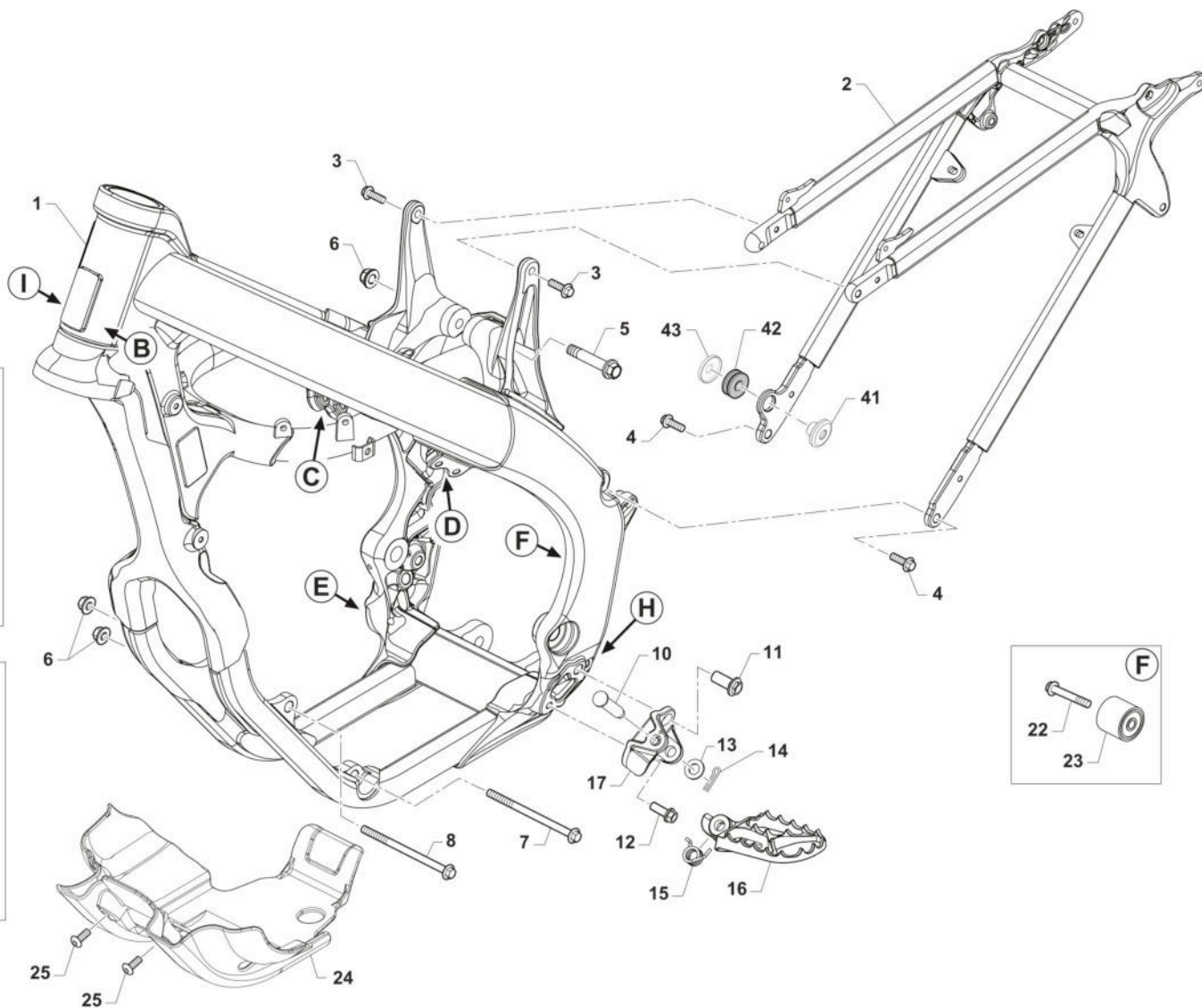
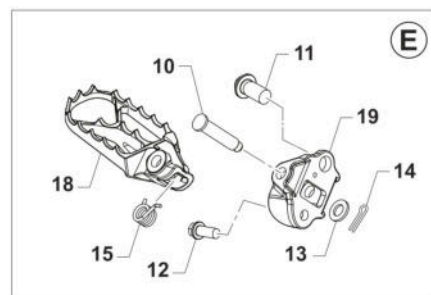
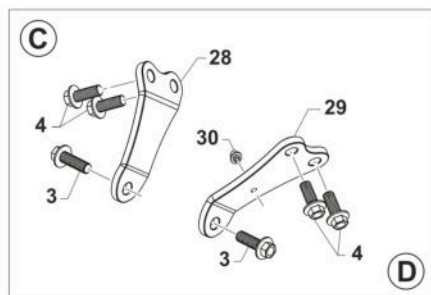
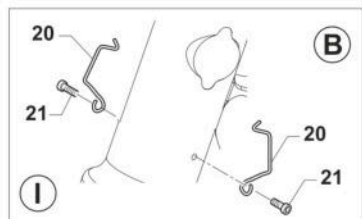

TM 0626.05



**4T300FIMX25**  
**4T 300 Fi MX - 4S 300 Fi MX**

**TELAIO**  
**FRAME**

Pos.	Codice	Q.tà	Note	Descrizione	Description
1	F73504	1		TELAIO 4T 250/300 MX MY 2022	
2	F73528	1		CODINO TELAIIO 4T MONO MY 22/24CON PREDISPOSIZIONE GOMMINO	
3	49364	4		VITE TE F/R 8X25 Ch.10	BOLT, EH 8X25 To.10 mm
4	49724	6		VITE TE F/R 8X21	BOLT TE F/R 8x21
5	49792	1		VITE TE F/R 10X54 1.25 T.AL08	BOLT, M10X1.25X54 ALU.FRAME08
6	49681	3		DADO M 10 X 1,25 CH 14 FLANG. AUTOBLOCK	NUT M10x1,25 FLANGED SELF-LOCK
7	49352	1		VITE TE F/R 10X125 1.25 Ch.10	BOLT SPECIAL 10X125 1.25 T.13
8	49351	1		VITE TE F/R 10X120 1.25 Ch.10	BOLT SPECIAL 10X120 1.25 T.10
10	73161	2		PERNO PEDANE MY2022	
11	49382	2		VITE ESAG.FLANG.M12X25 T.A.	BOLT 12 X 25 FLANGE
12	49383	2		VITE ESAG.FLANG.M8X1.25X20 T.A	BOLT 8 X 20 FLANGE
13	49612	2		RONDELLA ACCIAIO 10	STEEL WASHER 10
14	73036	2		COPIGLIA PEDANA M. 92/01	COTTER PIN FOOTPEG 92/01
15	F16481	2		MOLLA RITORNO PEDANA MY2022	
16	F73507	1		PEDANA SINISTRA MY2022	
17	F73509	1		SUPPORTO PEDANA SINISTRA MY2022	
18	F73506	1		PEDANA DESTRA MY2022	
19	F73508	1		SUPPORTO PEDANA DESTRA MY2022	
20	16021	2		MOLLA PASSAGGIO CAVI MOTO (SX)	GROMMET BIKES LF
21	49597	2		VITE TBCEI 4 x 8 UNI 7380	BOLT TBCE 4 x 8
22	49367	1		VITE TE F/R 8X45 Ch.10	BOLT 8X45 T.10mm
23	67088	1		ROTELLA CATENA M. 90/07	CHAIN ROLLER M.90/07
24	F50843	1		PARAMOTORE 4T 250/300 MY 2022	
25	F49861	2		VITE PARACOPPA E.I. M6X16 FL.	BOLT, GUARD ENGINE 6X16
26	49611	1		RONDELLA ACCIAIO 8	WASHER STEEL 8mm
27	49445	1		VITE TE 8X50 UNI 5737	BOLT EH 8X50
28	F26737	1		PIASTRINO DESTRO FISSAGGIO TESTA 4T 250	



4T300FIMX25

4T 300 Fi MX - 4S 300 Fi MX

TELAIO

FRAME

7

Pos.	Codice	Q.tà	Note	Descrizione	Description
29	F26738	1		PIASTRINO SINISTRO FISSAGGIO TESTA 4T 250	
30	51097	1		FASCETTA 148x3.6 PER FISSAGGI SU TELAI 150-55850	
41	48264	1		DISTANZIALE ESTERNO FISSAGGIO SCARICO	
42	21142	1		GOMMINO SILENZIATORE HGS MY22->	
43	48263	1		DISTANZIALE INTERNO FISSAGGIO SCARICO	



4T300FIMX25  
4T 300 Fi MX - 4S 300 Fi MX

PLASTICHE E SELLA  
PLASTIC AND SEAT

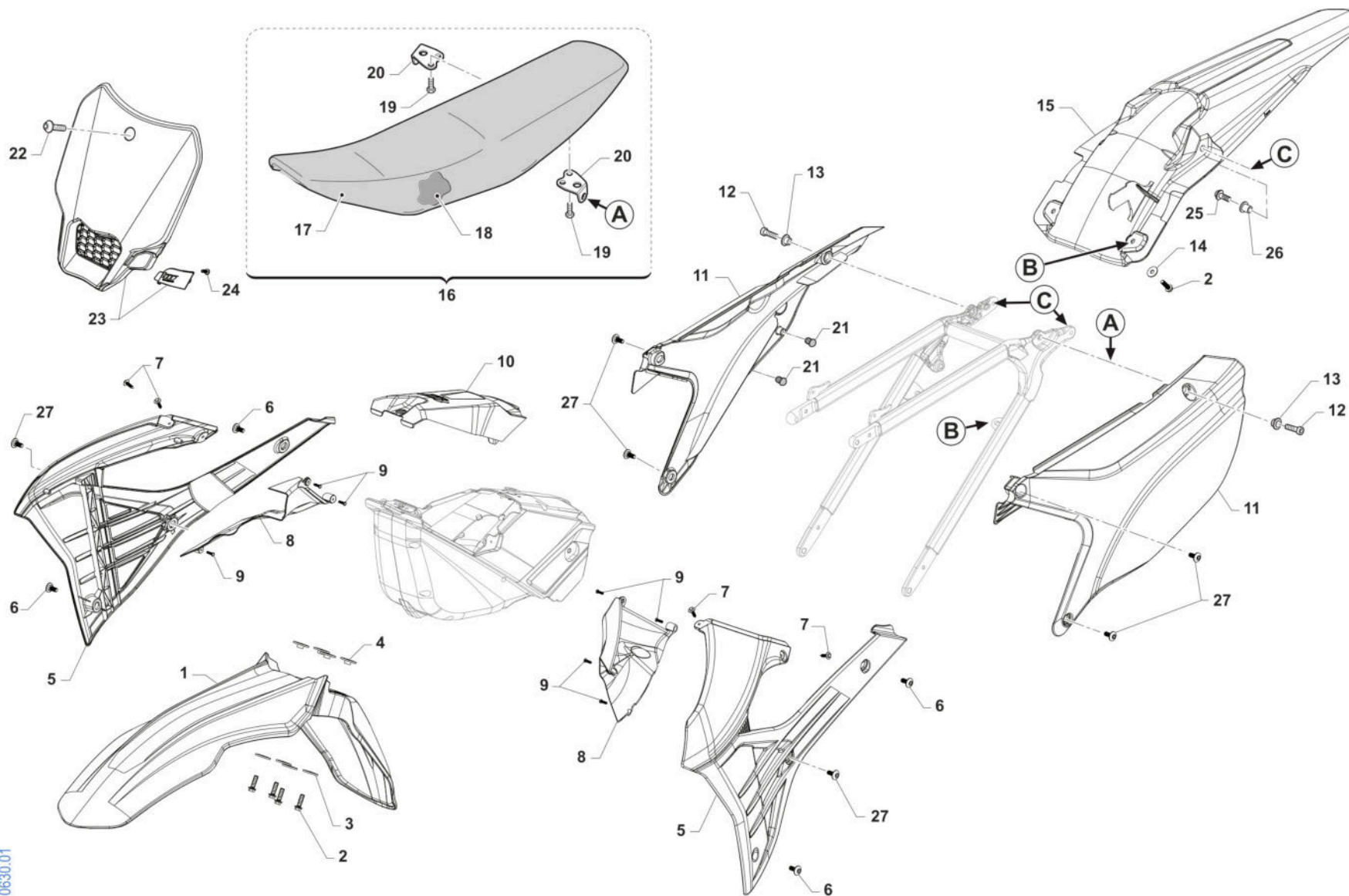

TM 0630.01



4T300FIMX25  
4T 300 Fi MX - 4S 300 Fi MX

PLASTICHE E SELLA  
PLASTIC AND SEAT

8

Pos.	Codice	Q.tà	Note	Descrizione	Description
1	67453	1		PARAFANGO ANTERIORE MY25 QUANTUM	
2	49356	6		VITE TE F/R 6X20 Ch.8	BOLT 6X20 T.8
3	26084	4		RONDELLA PARAF ANT. 24x2 M.08	WASHER, FRONT FENDER 24 X 2
4	26132	4		BOCCOLA PARAF. ANT. M12	BUSH, FRONT MUDGUARD M.12->
5	67470	1		SET CONV. ARIA 2T/4T MY25 QUANTUM	
6	49574	4		VITE TBCE 6 x 12 PLASTICHE	BOLT TBCE 6x12
7	49192	4		VITE TE COL.LARG.TL107 A 4X16 Chrm SERB.PL. MY22	
8	67271.22	1		SET CONVOGL. INTERNI 2T / 4T MY22->	
9	49984	7		VITE TCBL 3.0 X 12 FL. PLASTICA	BOLT
10	67465	1		COPERCHIO CASSA FILTRO MOTO 4T MY25 QUANTUM	
11	67473	1		SET LATER. P.NUM. 4T MONO MY25 QUANTUM	
12	49484	2		VITE TCEI 6X20	BOLT TCEI 6X20
13	26059	2		BOCCOLA FISS.SELLA & LAT.03/->	COLLAR, SEAT/SIDE PANEL 03/->
14	49117	2		RONDELLA 18X6.5X2 X RADIAT.08	WASHER 18X6.5X2 RADIATOR 08
15	67457	1		PARAFANGO POSTERIORE 2T/4T MY25 QUANTUM	
16	67478	1		SELLA M.2025 2T/4T CPL QUANTUM ALTATERMOSALDATA	
17	67479	1		COPERTINA SELLA M.2025 2T/4T QUANTUM ALTATERMOSALDATA	
18	67361	1		SPUGNA SELLA CROSS/ENDURO MOD.2022 2T/4T X 67363	
19	49435	4		VITE TE 5X12	SCREW TE 5X12
20	73047	2		PIASTRINO AL ATT.SELLA POSTER.	PLATE AI REAR SEAT HOLDER
21	21141	2		GOMMINO DIST.FIANC/SCARICO M22	
22	49574	1		VITE TBCE 6 x 12 PLASTICHE	BOLT TBCE 6x12
23	67475	1		PORTANUMERO ANTERIORE MY25 QUANTUM/NERO	
24	49128	1		VITE 7505B TC 4x12	
25	49356	2		VITE TE F/R 6X20 Ch.8	BOLT 6X20 T.8
26	26187	2		BOCCOLA FISSAGGIO PARAF/SUPP.COMP.ELET. MX/SMX MY22 15x6 F.6	





4T300FIMX25  
4T 300 Fi MX - 4S 300 Fi MX

PLASTICHE E SELLA  
PLASTIC AND SEAT

8

Pos.	Codice	Q.tà	Note	Descrizione	Description
27	490010	6		VITE TBCE 6 x 9 PLASTICHE	



4T300FIMX25  
4T 300 Fi MX - 4S 300 Fi MX

SERBATOIO  
FUEL TANK

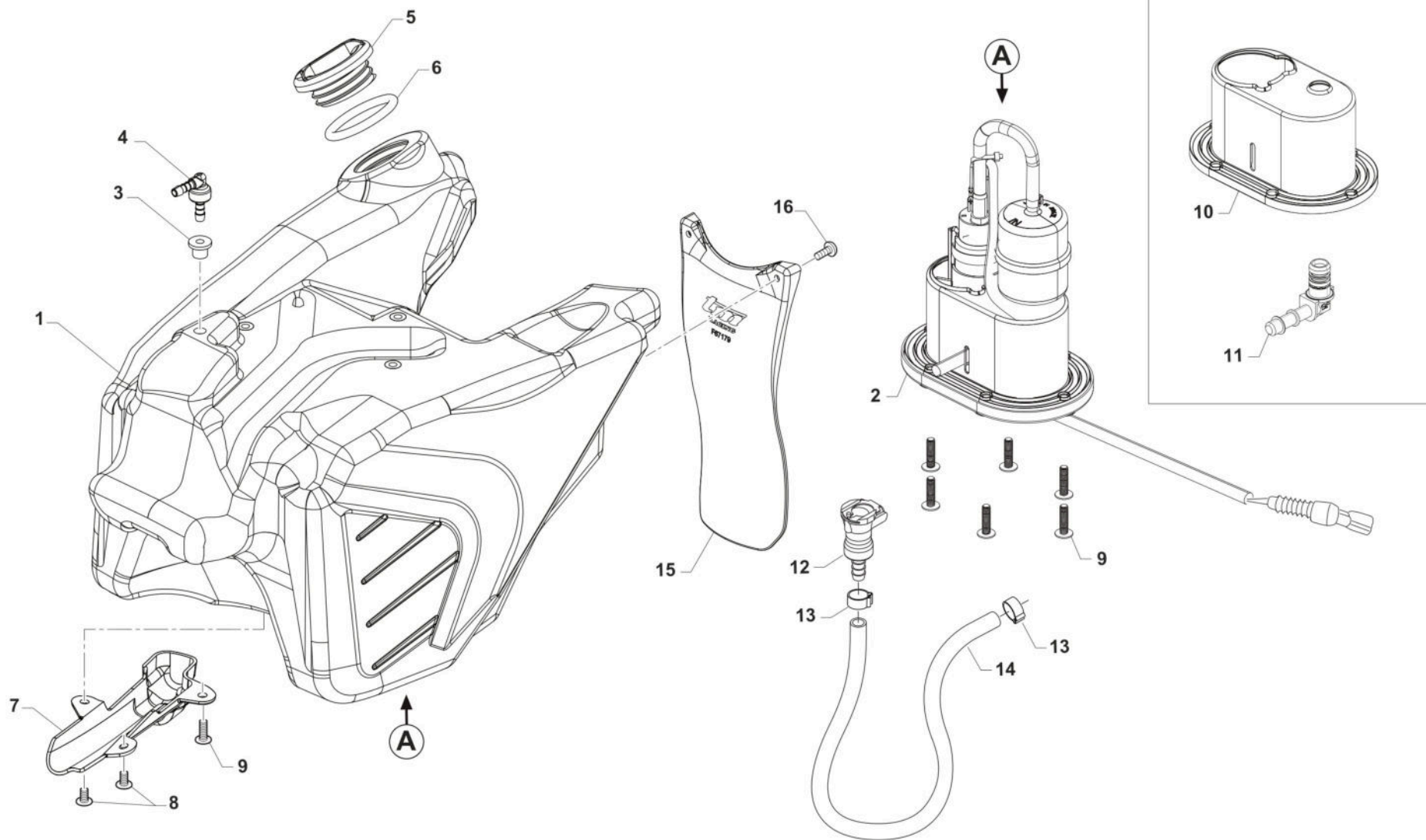

TM 0614.01



4T300FIMX25  
4T 300 Fi MX - 4S 300 Fi MX

SERBATOIO  
FUEL TANK

9

Pos.	Codice	Q.tà	Note	Descrizione	Description
1	F65139	1		SERBATOIO BENZINA MOTO 4T MY2022 TRASP.	
2	F08348	1		GRUPPO ASPIR. CARB. 3.5 BAR S/TERM.	FUEL PUMP ASSY 3,5 BAR WITHOUT TERM.
3	65035.2	1		PASSACAVO IN GOMMA DIAM.4,5 ARK DIS.174x KIT 65035	
4	F65142	1		VALVOLA DI SFIATO SERBATOIO MOTO 4T MY22	
5	F65140	1		TAPPO SERBATOIO 4T MY2022	
6	12039	1		O RING X TAPPO SERBATOIO 4T 15	O-RING TANK CAP F.S. 15->
7	F65136	1		CARTER CAVI POMPA BENZINA	PROTECTION, FUEL PUMP CABLES
8	49448	2		VITE TBCEI 5X10 UNI 7380	BOLT TBCEI 5X10 10.9
9	49754	7		VITE TBCIX 5X20	BOLT TBCIX 5x20
10	F05866	1		KIT RICAMBIO GUARNIZIONE POMPA BENZINA	
11	F08122	1		RACC.MASCHIO GR.P.BENZ.BITRON	JOINT, FUEL PUMP Fi
12	F08370	1		RACCORDO SG.RAPIDO CPC 5/16 C/V	JOINT CPC 5/16 C/V
13	F51112	2		FASCETTA OETIKER 016,0-706R	CLAMP OETIKER 016,0-706R
14	67036	1		TUBO ANTIBENZINA 8 x 14	HOSE, OIL/FUEL 8x14
15	F67179	1		PROTEZIONE MONO MOTO 4T MY22	
16	490007	2		VITE TBCEI 5 x 12 7380 FLANGE 10.9	BOLT TBCEI 5 x 12 7380 FLANGE



4T300FIMX25  
4T 300 Fi MX - 4S 300 Fi MX

# FORCELLONE SWINGARM

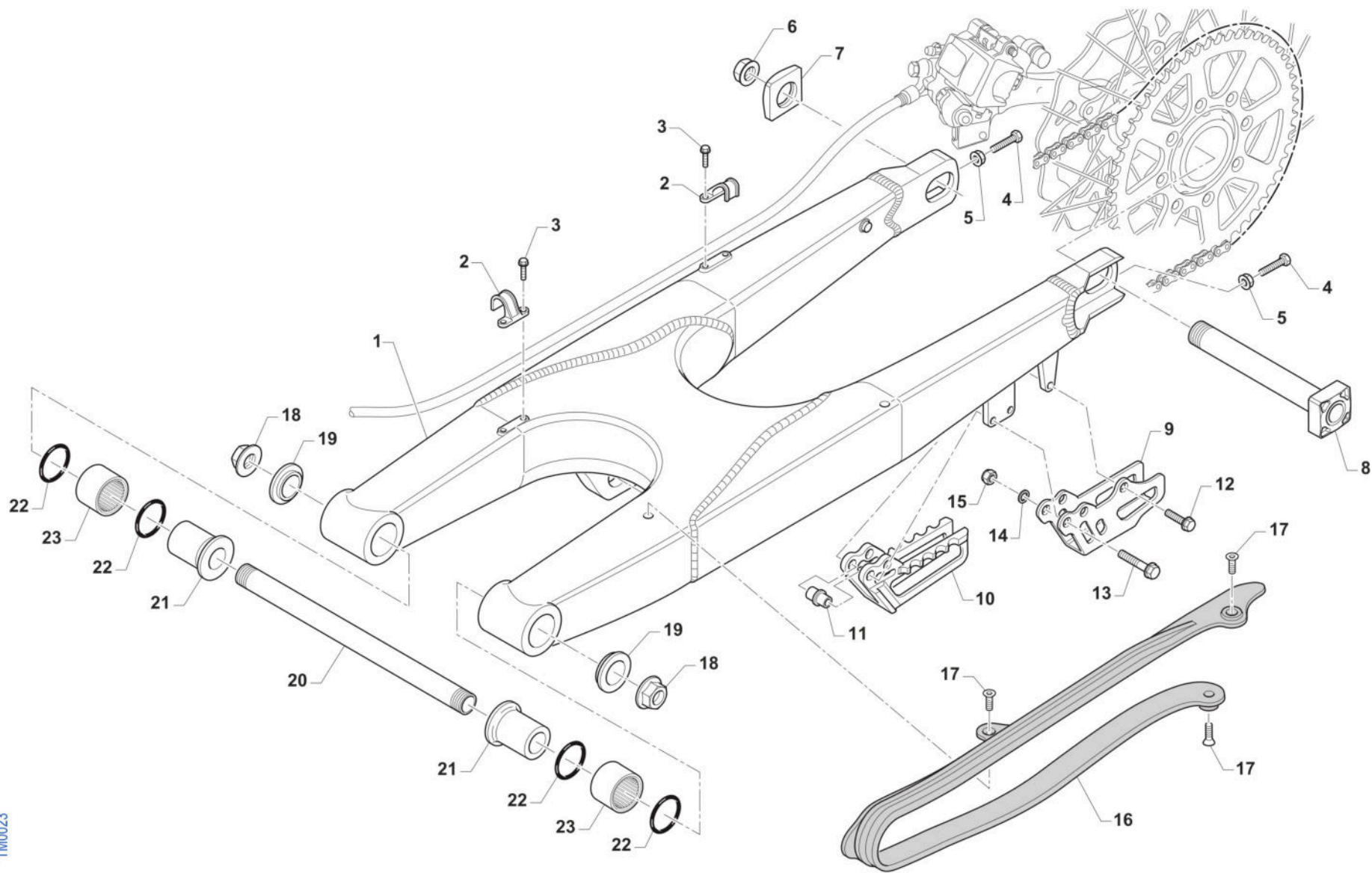

TM0023



**4T300FIMX25**  
**4T 300 Fi MX - 4S 300 Fi MX**

**FORCELLONE**  
**SWINGARM**

**10**

Pos.	Codice	Q.tà	Note	Descrizione	Description
1	73099.15	1		FORCELLONE MOTO 2T/4T MY 15/22	SWINGARM 2S MY 15
2	67054	2		FERMA TUBO FRENO POST. M.97/->	RETAIN CLAMP BRAKE HOSE 97/->
3	49794	4		VITE AUTOFOR. 4.8X16 7504	BOLT, 4,8 X 16 7504
4	F49976	2		VITE TE 8X45 ES.10 FORCELLONE	SCREW TE 8X45 SWINGARM
5	49640	2		DADO M 8 FLANGIATO CHIAVE 12	NUT 8mm, FLANGE
6	49123	1		DADO PERNO RUOTA POST. M.2015	NUT, REAR WHEEL AXLE 15 ->
7	70140.15	1		TENDICATENA 2015 SENZA FILETTO	ADJ BLOCK, CHAIN 15-THREADLESS
8	74055.15	1		PERNO RUOTA POSTERIORE M.15->	AXLE, REAR WHEEL M.15->
9	73130	1		PASSACATENA ALLUM. MOD. 11/->	PLATE, CHAIN GUIDE M. 11/->
10	67102.10	1		PASSACATENA NYLON MOD.2011	GUIDE, CHAIN M. 11/->
11	26092	1		BOCCOLA PASSACATENA M.11->	BUSH, CHAINGUIDE M11->
12	49370	1		VITE TE F/R 6X12	BOLT 6X12
13	49362	2		VITE TE F/R 6X50 Ch.8	BOLT 6X50 T.8
14	49603	2		RONDELLA M 6,4 X 12 X 1,6	WASHER 6x12
15	49638	2		DADO M 6 ALTO AUTOBLOCCANTE	NUT 6mm, HIGHT SELF-LOCKING
16	67099.15	1		PROTEZIONE FORCELLONE M.2015	SWINGHARM PROTECTION M.2015
17	49396	3		VITE TSEI 5X10	BOLT TSEI 5X10
18	49095	2		DADO 16 FORCELLONE MOTO 95/10	NUT, SWINGARM AXLE M. 95/05
19	73115	2		COPERCHIO BOCCOLA FORC. M08->	COLLAR, SWINGARM M.08
20	74056	1		PERNO FORCELLONE MOD. 08/->	AXLE SWINGARM M. 08->
21	73112	2		BOCCOLA FORC. 08/-> F16(30X49)	BUSH, SWINGARM 08-> H.16 30X49
22	12102	4		O RING LEVERAGGIO & FORCELLONE	O-RING, LINKAGE & SWINGARM
23	19043	2		ASTUCCIO A RULLI HK 20/30	NEEDLE CAGE HK 20/30



4T300FIMX25  
4T 300 Fi MX - 4S 300 Fi MX

# LEVERAGGI LINKAGE

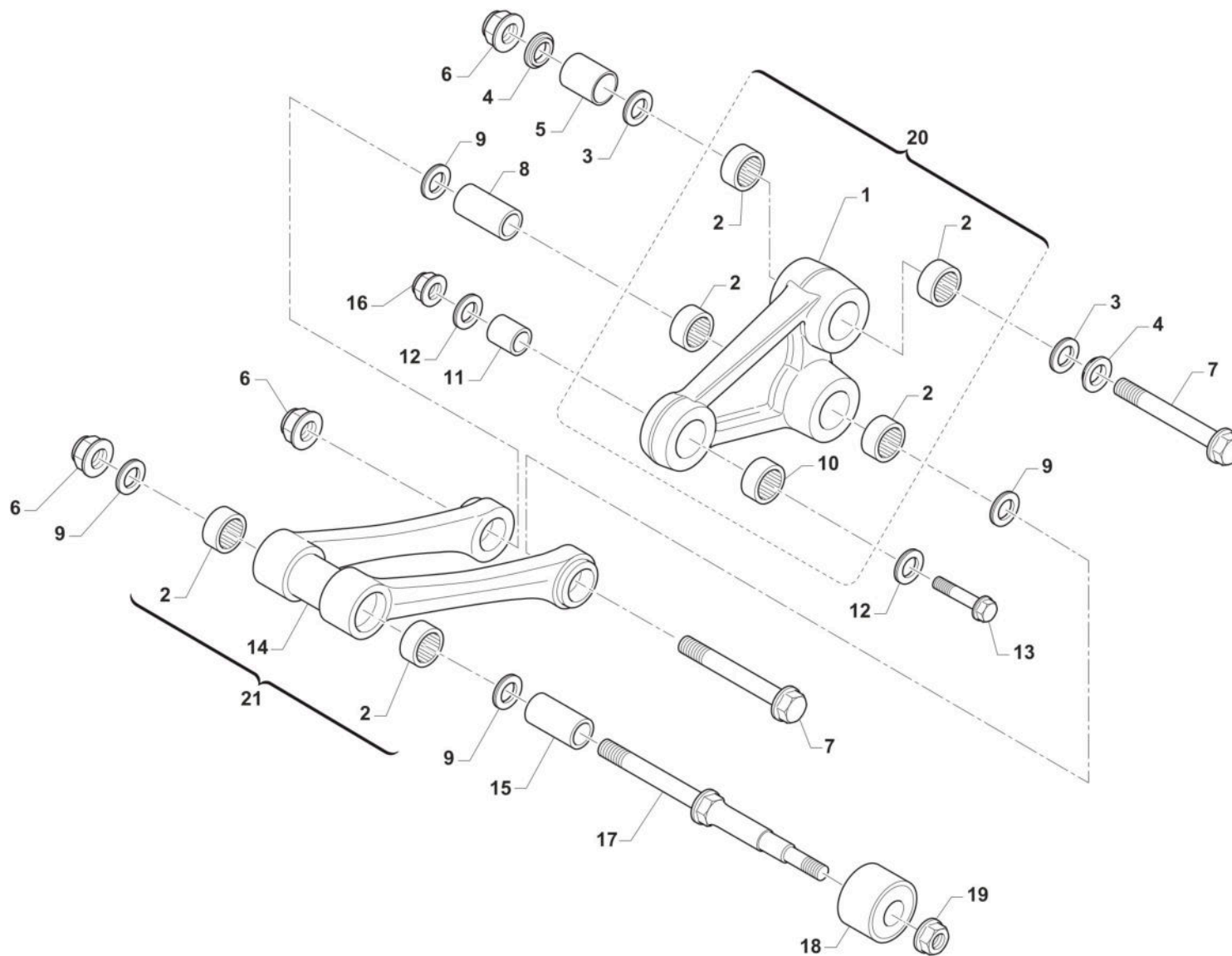

TM 0645



4T300FIMX25  
4T 300 Fi MX - 4S 300 Fi MX

LEVERAGGI  
LINKAGE

Pos.	Codice	Q.tà	Note	Descrizione	Description
1	73145	1		TRIANGOLO SOSP. MY 15/23 NUDO	ARM
2	19106	6		GABBIA RULLINI DL 2016 KYU	BUSH NEEDLE CAGE 26 X 20 H16
3	12010	2		O RING ORM 0240-30 TRIANG.05/6	O-RING, LINKAGE 05/6 ORM 0240-30
4	73075	2		COPERCHIO BOCCOLA TRIANG '05	COVER, BUSH
5	73211	1		BOCCOLA TRIANGOLO LEVER.05/->	BUSH, ARM RELAY 12X20X38
6	49194	3		DADO M12X1.25 FLANG. CH14	
7	49345	2		VITE TE F/R 12X90 1.25 Ch13	BOLT TE F/R 12X90 1.25 T.13
8	F73416	1		BOCCOLA TRIANG. 20x48F12 05/->	COLLAR, ROD M.04 12x20x48
9	12102	4		O RING LEVERAGGIO & FORCELLONE	O-RING, LINKAGE & SWINGARM
10	19101	1		GABBIA RULLINI DL 1812 KYU	BUSH NEEDLE CAGE DL 18/12
11	73214	1		BOCCOLA 18 X 20 F.10 TRIANGOLO 07/->	COLLAR, ARM ASSY 10 18X20 M.07
12	F12312	2		O RING FILTRO OLIO P.ASPIRAZ.+LEV.	O-RING, OIL FILTER
13	49347.1	1		VITE TE F/R 10X43 1.25 Ch.13	BOLT TE F/R 10X43 1.25 T.10
14	73144	1		TRAPEZIO SOSP. MY 15/23 NUDO	CONROD LINKAGE MY.15
15	73204	1		BOCCOLA TRAPEZIO 20 x 74 F.12	BUSHING 20x74x12, ROD SUSP. 05
16	F49874	1		DADO M 10 X 1,25 CH 12 FLANGIATO	NUT FLANGED M 10x1,25 T.12mm
17	49790	1		PERNO SNODO BIELLA/ROT.CAT.M08	PIVOT, LINKAGE/ROLLER 08/->
18	67088.08	1		ROTELLA CATENA M. 08/->	CHAIN ROLLER 08/->
19	49676	1		DADO M 6X1 FLANG. AUTOBL.ACC.	NUT, FLANGED M6 X 1 S.B.
20	73016.15	1		TRIANGOLO SOSP. MY 15/22 CPL	ARM ASSY RELAY M.Y.2015
21	73059.15	1		TRAPEZIO SOSP. MY 15/-> CPL	ROS, ASSY



4T300FIMX25  
4T 300 Fi MX - 4S 300 Fi MX

RUOTA POSTERIORE 19x2.15  
REAR WHEEL 19x2.15

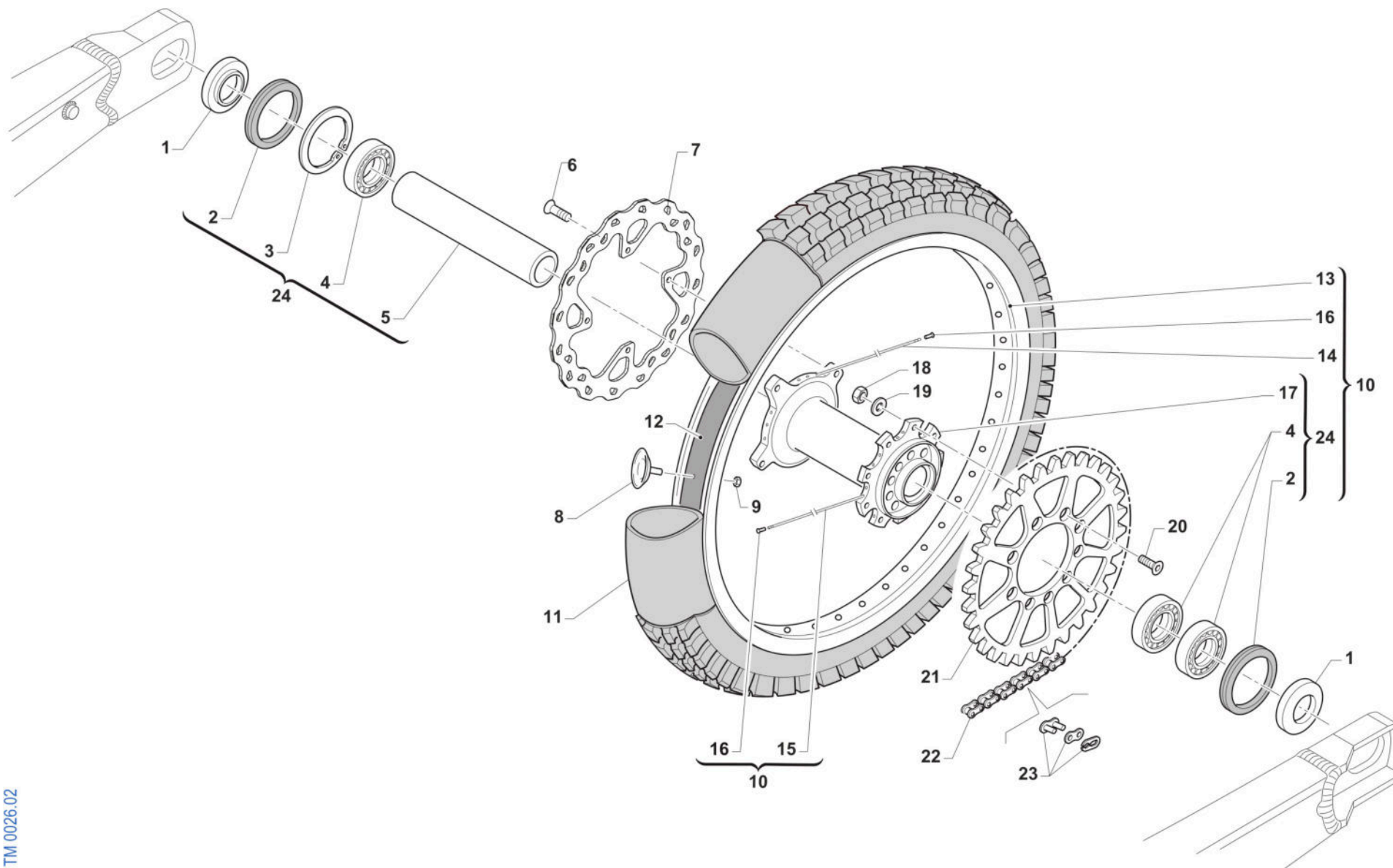

TM 0026.02





4T300FIMX25  
4T 300 Fi MX - 4S 300 Fi MX

RUOTA POSTERIORE 19x2.15  
REAR WHEEL 19x2.15

12

Pos.	Codice	Q.tà	Note	Descrizione	Description
1	70241	2		DISTANZ. RUOTA PST. 2015 DX/SX	COLLAR REAR WHEEL LE.RI. 15->
2	04074	2		PARAPOLVERE RUOTA POST. MOD.15->	DUST SEAL, REAR WHEEL 15 ->
3	49257	1		SEEGER I 43 mm	CIRCLIP D. 43 INTERNAL
4	03071	3		CUSCINETTO RUOTA ANTER. + POSTER.	BUSH, FRONT WHEEL MA50 61905
5	70240	1		DIST.INT.MOZZO RUOTA PST.15 3C 114,2x31 SP2.7	SPACER INT.REAR WHEEL M.15->
6	49355	4		VITE TE F/R 6X16 Ch.8	BOLT 6X16 T.8
7	69388	1		DISCO FRENO POSTERIORE 240X4 TM	
8	70028	1		FERMA COPERTURA POST. 2.15	STOPPER 2.15
9	49640	1		DADO M 8 FLANGIATO CHIAVE 12	NUT 8mm, FLANGE
10	70148.15	1		CERCHIO PST. CPL 19x2.15 M15->	RIM, REAR ASSY 19x2.15 M15->
11	80152	1		CAMERA ARIA POSTERIORE 19	TUBE, TYRE 19
12	70038	1		FLAP RUOTA POSTERIORE 19	FLAP REAR WHEEL 19
13	70053	1		CERCHIO POST 19x2.15 TAKASAGO BLU	REAR RIM 2.15x19 Takasago
14	70259	18		RAGGIO R.PST.4.0/3.3/4.0 X 204	SPOKE R.WHEEL 4.0/3.3/4.0 X204
15	70258	18		RAGGIO R.PST.4.0/3.3/4.0 X 211	SPOKE R.WHEEL 4.0/3.3/4.0 X211
16	70062	36		NIPPLO ACCIAIO 4	SPOKE NIPPLE 4 mm
17	70316	1		MOZZO POST NUDO VMX MY2021	
18	49643	9		DADO M 8 BASSO AUTOBLOCCANTE	NUT 8mm, LOW SELF-LOCKING
19	49611	9		RONDELLA ACCIAIO 8	WASHER STEEL 8mm
20	49421	9		VITE TSEI 8X25	BOLT TSEI 8X25
21	70103.53	1		CORONA CATENA Z 53 M. 86/->	SPROCKET 53T, REAR, M.86/->
21	70290.48	1		CORONA CATENA Z 48 M. 86/-> ZF	SPROCKET 48T MY 86-> ZF
21	70290.49	1		CORONA CATENA Z 49 M. 86/-> ZF	SPROCKET 49T MY 86-> ZF
21	70290.50	1		CORONA CATENA Z 50 M. 86/-> ZF	SPROCKET 50T MY 86-> ZF
21	70290.51	1		CORONA CATENA Z 51 M. 86/-> ZF	SPROCKET 51T MY 86-> ZF
21	70290.52	1		CORONA CATENA Z 52 M. 86/-> ZF	SPROCKET 52T MY 86-> ZF
21	70291.49	1		CORONA BLU/NERA ALLU/ACCIAIO Z49 ZF	SPROCKET BLUE/BLACK ALU/STEEL 49 T ZF
21	70291.50	1		CORONA BLU/NERA ALLU/ACCIAIO Z50 ZF	SPROCKET BLUE/BLACK ALU/STEEL Z50 ZF



4T300FIMX25

4T 300 Fi MX - 4S 300 Fi MX

RUOTA POSTERIORE 19x2.15

REAR WHEEL 19x2.15

12

Pos.	Codice	Q.tà	Note	Descrizione	Description
21	70291.51	1		CORONA BLU/NERA ALLU/ACCIAIO Z51 ZF	SPROCKET BLUE/BLACK ALU/STEEL 51T ZF
21	70291.52	1		CORONA BLU/NERA ALLU/ACCIAIO Z52 ZF	SPROCKET BLUE/BLACK ALU/STEEL 52 T ZF
22	70100	1		CATENA REGINA 114MG	REGINA CHAIN 135 RX 114
23	70098	1		GIUNTO CATENA REGINA 135 RX3	CHAIN LINK 135 RX3
24	70119.15	1		MOZZO POSTERIORE 2015 CPL	REAR HUB 2015 -> ASSY



4T300FIMX25  
4T 300 Fi MX - 4S 300 Fi MX

FRENO POSTERIORE  
REAR BRAKE

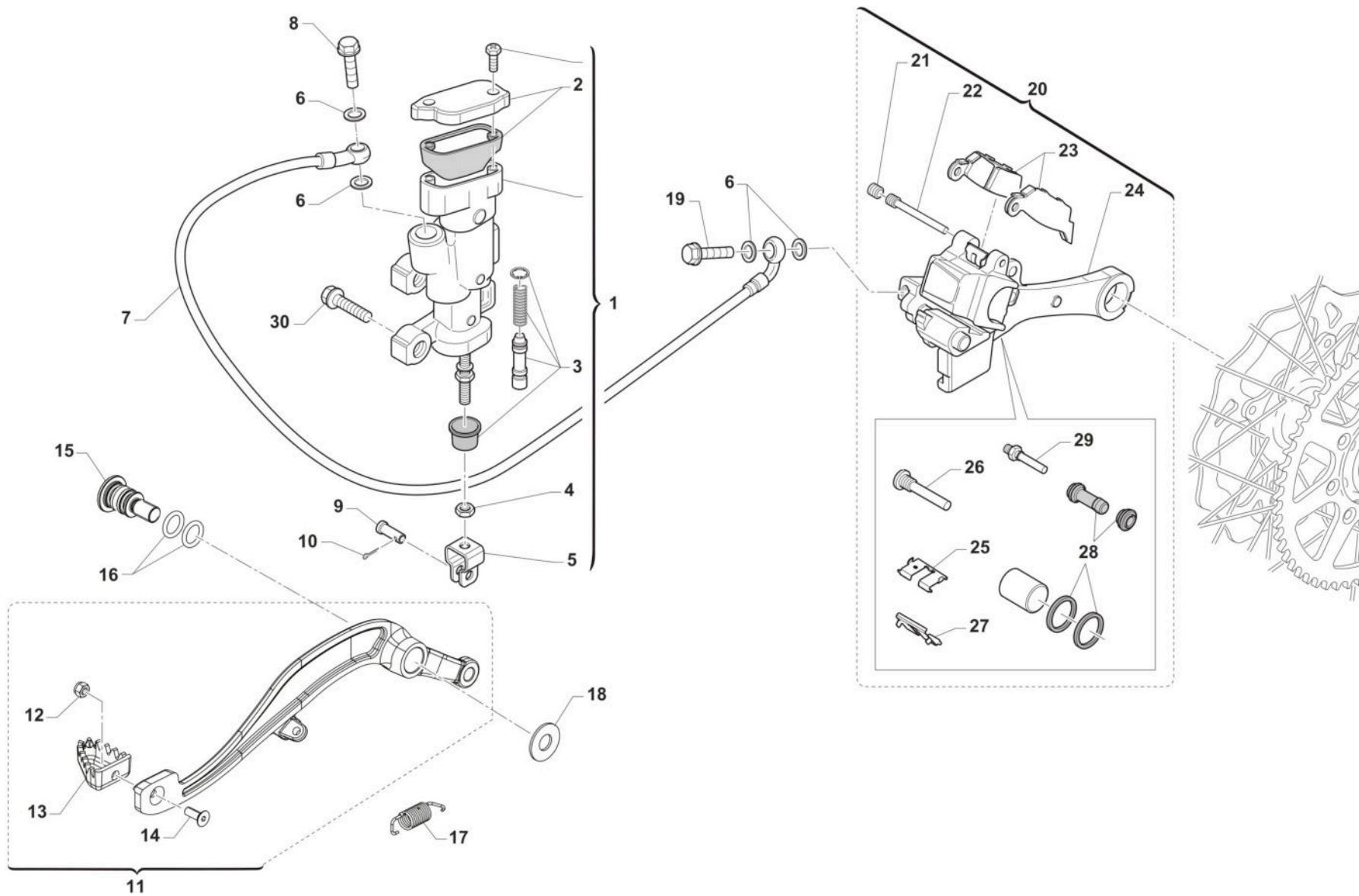

TM 0615.01



4T300FIMX25  
4T 300 Fi MX - 4S 300 Fi MX

FRENO POSTERIORE  
REAR BRAKE

13

Pos.	Codice	Q.tà	Note	Descrizione	Description
1	69345	1		POMPA FRENO POST 05/-> INTEGR (OBLO' 2020)	
2	69321	1		KIT TAPPO/GUARN. POMPA PST NIS	CAP AND RUBBER
3	69084.05	1		KIT REV. PIST.POMPA POST.05/->	KIT, REV. REAR MASTER CYL.05->
4	49636	1		DADO M 6	NUT M6
5	69125	1		FORCHETTINA POMPA FRENO POS.05	FORK, REAR BRAKE 05
6	69034	4		RONDELLA X BULLONE FREN B22001	WASHER B22001, BRAKE HOSE
7	69379	1		TUBO FRENO POSTERIORE 2T/4T M.2022	
8	69094	1		BULLONE 10X1.25 T.FRENO NISSIN 03	BOLT,10X1,25 BRAKE HOSE NISSIN
9	69012.05	1		PERNO SNODO FRENO POST. MY 05->	PIN REAR BRAKE MASTER CYL. MY 05->
10	68997	1		COPIGLIA PEDALE FRENO	COTTER PIN BRAKE PEDAL
11	69000.22	1		PEDALE F.POST 2T 125/144 + 4T 250/300 MY 22	BRAKE PEDAL, REAR 2S 125/144 + 4S 250/300 MY 22
12	49629	1		DADO M 5 ALTO AUTOBLOCCANTE	NUT 5mm, HIGHT SELF-LOCKING
13	69002.99	1		PARTE ANT.PED.FRENO POST.99/->	PIT, RR BRAKE PEDAL 99/->
14	49400	1		VITE TSEI 5X14	BOLT TSEI 5x14
15	F49063	1		VITE FISSAGGIO PEDALE FRENO MY22	
16	12110	2		O RING PEDALE FRENO POST. MY22->	
17	F16482	1		MOLLA PEDALE FRENO MY 22	
18	F48403	1		RONDELLA PEDALE FRENO MY22	
19	69094	1		BULLONE 10X1.25 T.FRENO NISSIN 03	BOLT,10X1,25 BRAKE HOSE NISSIN
20	69185.15	1		PINZA FRENO POST. 15-> NISSIN	BRAKE CALIPER, REAR, M. 15/->
21	69087	1		GRANO PERNO 69088 NISSIN 01/11	SCREW PLUG FOR BRAKE PIN 01/07
22	69088	1		PERNO PAST. POST NISSIN 01/11	PIN, RR BRAKE NISSIN M. 01/->
23	69096.05	1		PASTIGLIE FRENO POST. M.05-> NISSIN	PAD ASSY, RR BRAKE NISSIN MY 05->
24	69285.15	1		SUPPORTO PINZA D. 25 FRENO POST NISSIN 15/->	HOLDER, REAR BRAKE CALIPER
25	69309	1		PIASTR.FERMA P.NISSIN RETAINER	RETAINER BRAKE PADS NISSIN
26	69257	1		PERNO/VITE PINZA POST.01/->	PIN, RR BRAKE CALIPER 01-> NI.
27	69086	1		LAMIERINO PINZA POST NIS 01/->	PLATE, REAR BRAKE CALIPER 01->
28	69258	1		KIT REV.GOMM. PINZA PST 05/->	REAR BRAKE CALIPER RUBBER REVIEW 05/->



4T300FIMX25

4T 300 Fi MX - 4S 300 Fi MX

FRENO POSTERIORE

REAR BRAKE

13

Pos.	Codice	Q.tà	Note	Descrizione	Description
29	69232	1		PERNO X PINZA FRENO POST.05/12	PIN, RR BRAKE CALIPER 05/12
30	49574	2		VITE TBCE 6 x 12 PLASTICHE	BOLT TBCE 6x12



4T300FIMX25  
4T 300 Fi MX - 4S 300 Fi MX

### SCARICO EXHAUST SYSTEM

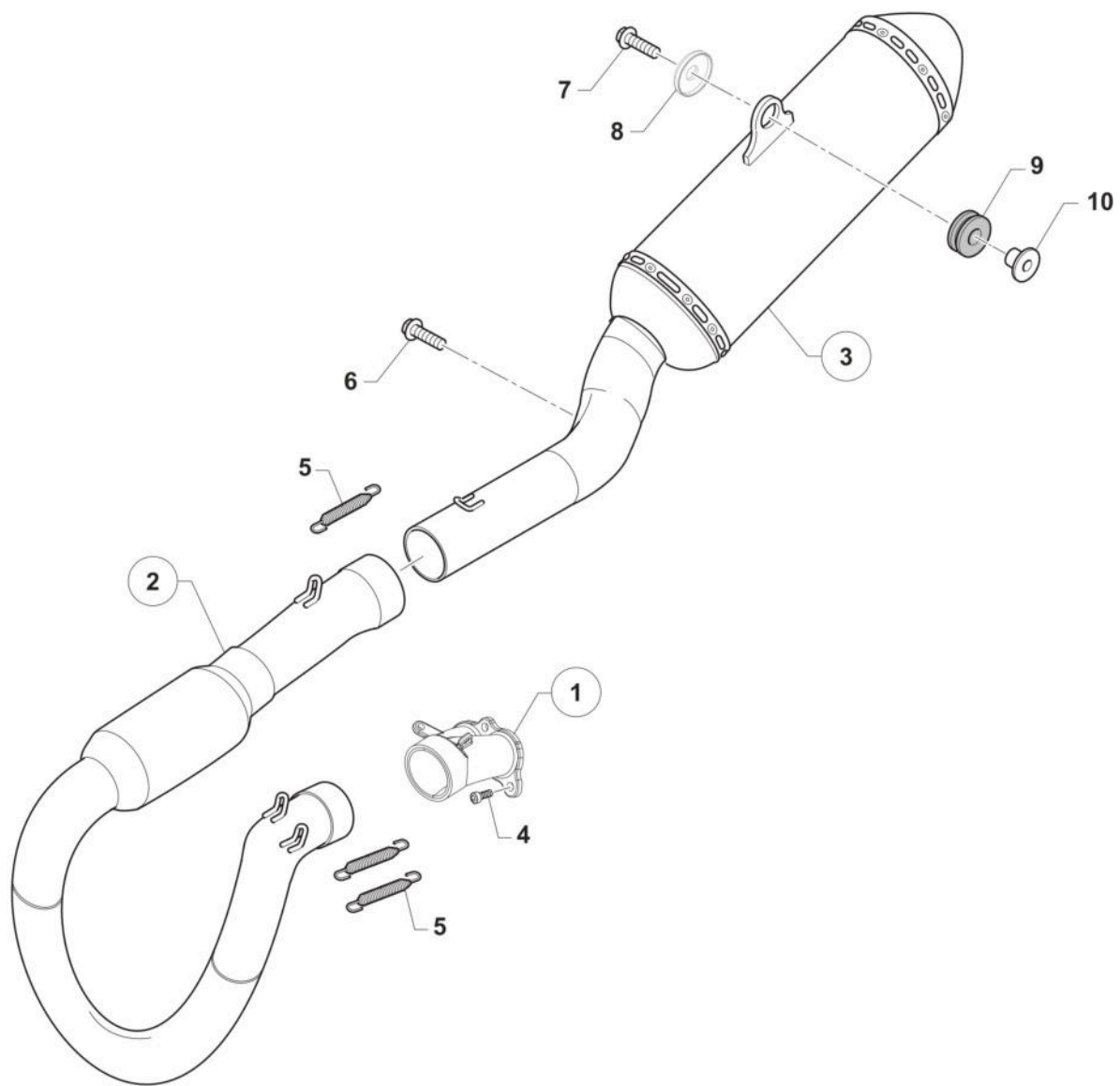

TM 0613.09



4T300FIMX25  
4T 300 Fi MX - 4S 300 Fi MX

SCARICO  
EXHAUST SYSTEM

14

Pos.	Codice	Q.tà	Note	Descrizione	Description
1	27303	1		COLLETORE DI SCARICO MONO D35 250-300 4T	
2	27286	1		COLLET. SEC. 300 4T MX/EN MY2025	
3	27279	1		SILENZIATORE 250/300 4T MX MY2025	
4	49483	3		VITE TCEI 6X16 UNI 5931	BOLT TCEI 6X16
5	F27476	3		MOLLA TR.SCARICO BICONICA 4T M08 MM42 ACCIAIO INOX	SPRING, EXHAUST MM42 INOX
6	490006	1		VITE TBCEI 8 x 20 ISO 7380 FLANGE 10.9	
7	49868	1		VITE T.C. 4X50	
8	48264	1		DISTANZIALE ESTERNO FISSAGGIO SCARICO	
9	21142	1		GOMMINO SILENZIATORE HGS MY22->	
10	26196	1		BOCCOLA GOMMINO SILENZ. HGS MY22->	



4T300FIMX25  
4T 300 Fi MX - 4S 300 Fi MX

CABLAGGI  
EXHAUST

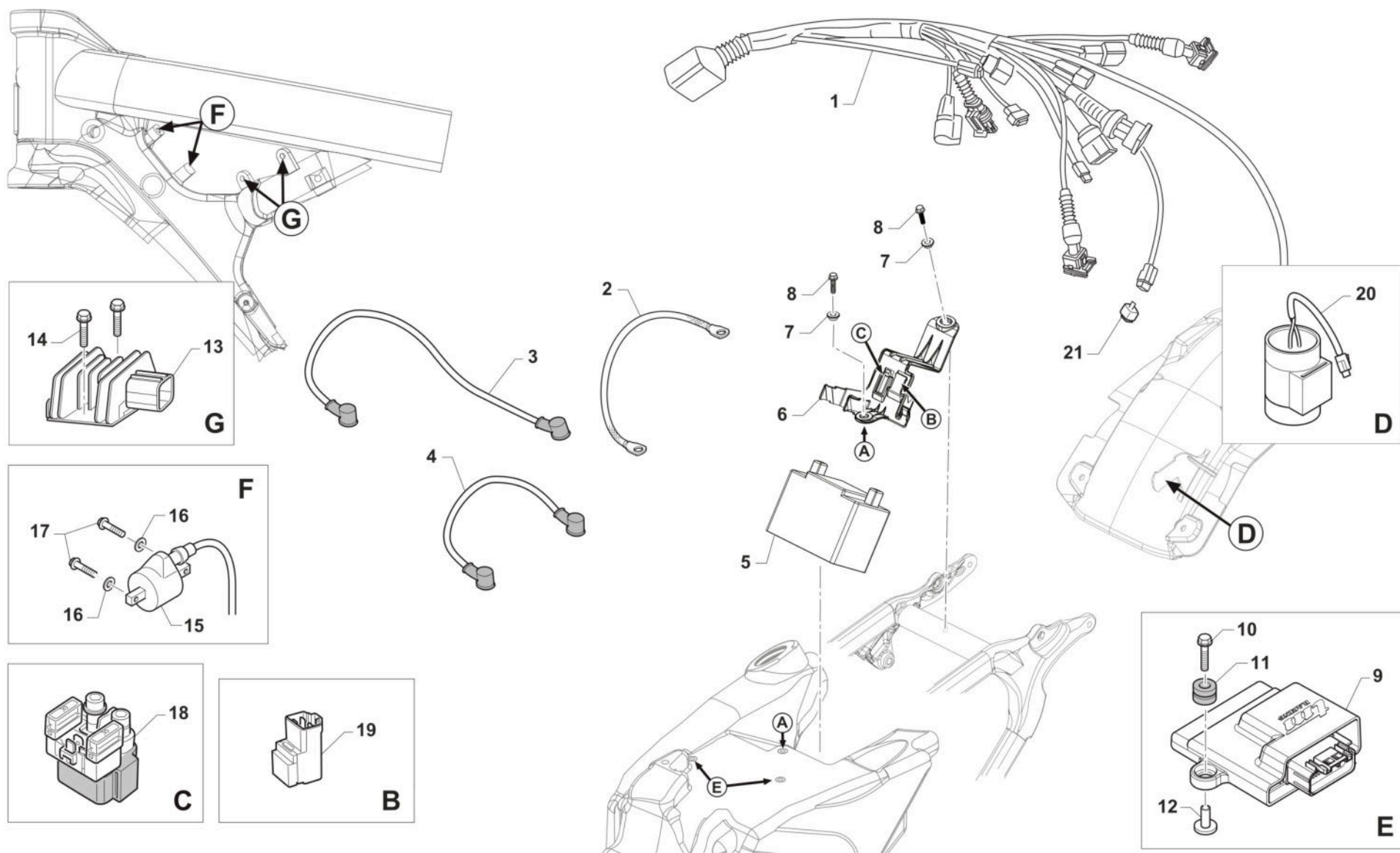

TM 0621





4T300FIMX25  
4T 300 Fi MX - 4S 300 Fi MX

CABLAGGI  
EXHAUST

15

Pos.	Codice	Q.tà	Note	Descrizione	Description
1	F68329	1		CABLAGGIO 4T 250/300/450/530 Fi MY2022	
2	50267	1		TRECCIA DI MASSA E.S. MY 22->	
3	F68334	1		CAVO BATTERIA NERO M. 2022	
4	F68333	1		CAVO BATTERIA ROSSO M. 2022	
5	68226	1		BATTERIA ALIANT YLP14 12V 14AH	
6	F68326	1		SUPPORTO COMPONENTI ELETTRICI MOTO 4T MY22	
7	26187	2		BOCCOLA FISSAGGIO PARAF/SUPP.COMP.ELET. MX/SMX MY22 15x6 F.6	
8	49374	2		VITE TB LARGA 5X20	BOLT TB 5X20
9	08117.0	1		CENTRALINA MX 300 4T MODELLO 2025	
10	49913	2		VITE TE/FLANG. 5X20	
11	21045	2		GOMMINO C/CHILOM. & CDI 08/11	RUBBER, SPEEDOMETER/CDI 08/13
12	F26498	2		BOCCOLA CENTRALINA INIEZIONE	
13	F15559	1		REGOLATORE KOKUSAN RX4513 ZERO SOSTITUISCE COD. F15476	REGULATOR KOKUSAN RX4513 REPLACE CODE F15476
14	49356	2		VITE TE F/R 6X20 Ch.8	BOLT 6X20 T.8
15	F15458	1		BOBINA KOKUSAN 4T MX PICCOLA	COIL, INGNITION KOK IG5132
16	49603	2		RONDELLA M 6,4 X 12 X 1,6	WASHER 6x12
17	49357	2		VITE TE F/R 6X25 Ch.8	BOLT 6X25 T.8
18	F68102	1		RELAY AVV. ELETTRICO 2 e 4 TEMPI	RELAY, ELECTRIC STARTER
19	F68212	1		RELAY AVV. ELETTRICO PAN. M2015->	RELAY EL. STARTER M.-> 15
20	F15557	1		CONDENSATORE SHINDENGEN ADP19	CAPACITOR SHINDENGEN ADP19
21	F68184	1		DIODO SDG	



4T300FIMX25  
4T 300 Fi MX - 4S 300 Fi MX

KIT ADESIVI MX

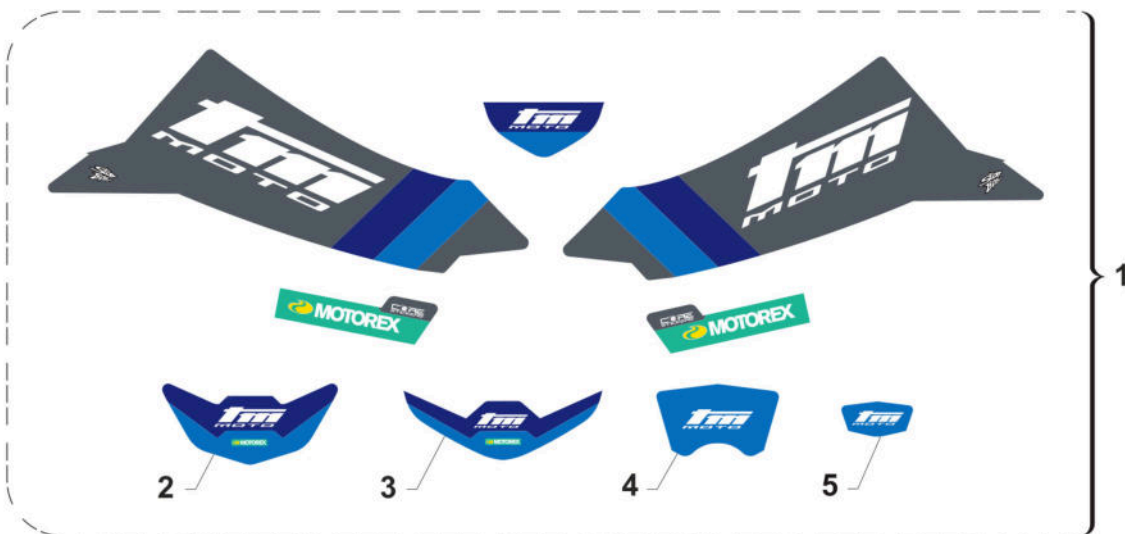

2S MX

4S MX

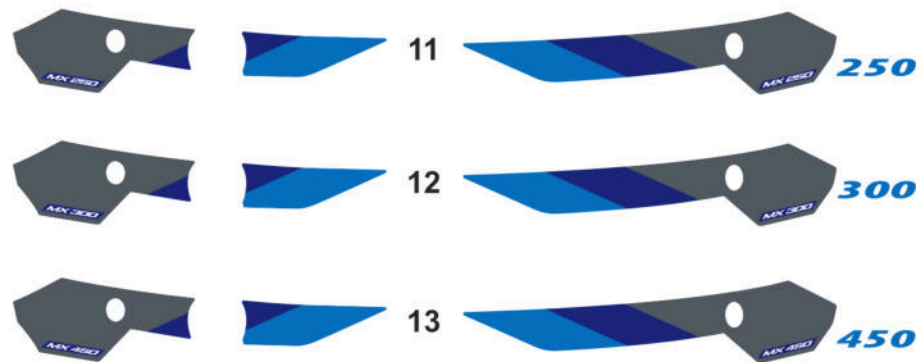
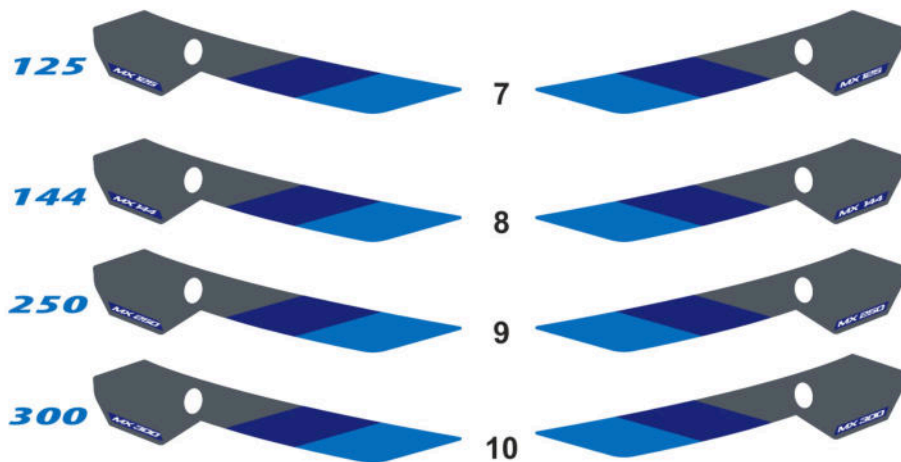

KA25-MX



4T300FIMX25

4T 300 Fi MX - 4S 300 Fi MX

KIT ADESIVI MX

18

Pos.	Codice	Q.tà	Note	Descrizione	Description
1	94317.25	1		KIT ADESIVI - TM MOTO - M.2025 S/POST.	
2	94104.25	1		ADESIVO PARAFANGO ANT. SM -TM MOTO- MY25	
3	94037.25	1		ADESIVO PARAFANGO ANT. -TM MOTO- MY25	
4	94161.25	1		ADESIVO PORTAFARO -TM MOTO- MY25	
5	94160.25	1		ADESIVO P.NUM.ANT. -TM MOTO- MY25	
6	94111.15	1		KIT ADESIVI FORC. KAYABA ROSSI	STICKERS KYB FORK RED
7	94289.125	1		KIT AD. LAT. P.NUM 2T MX 125 MY25	
8	94289.144	1		KIT AD. LAT. P.NUM 2T MX 144 MY25	
9	94289.250	1		KIT AD. LAT. P.NUM 2T MX 250 MY25	
10	94289.300	1		KIT AD. LAT. P.NUM 2T MX 300 MY25	
11	94290.250	1		KIT AD. LAT. P.NUM 4T MX 250 MY25	
12	94290.300	1		KIT AD. LAT. P.NUM 4T MX 300 MY25	
13	94290.450	1		KIT AD. LAT. P.NUM 4T MX 450 MY25	



4T300FIMX25  
4T 300 Fi MX - 4S 300 Fi MX

CILINDRO - PISTONE  
CYLINDER - PISTON

1

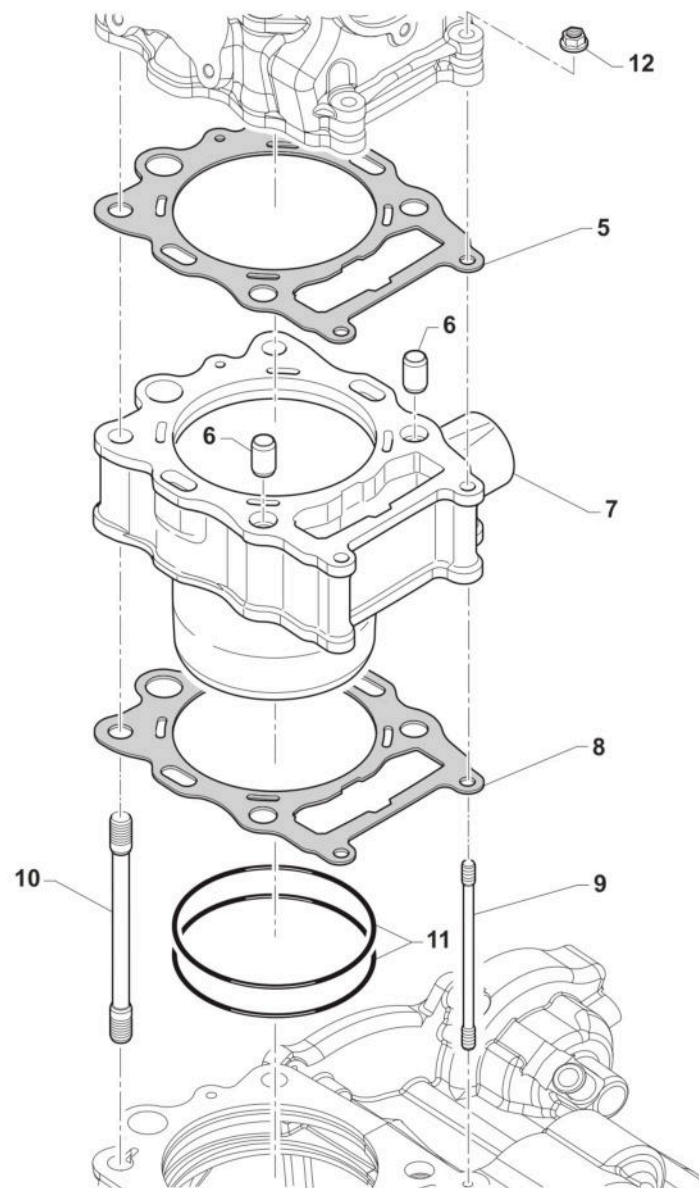
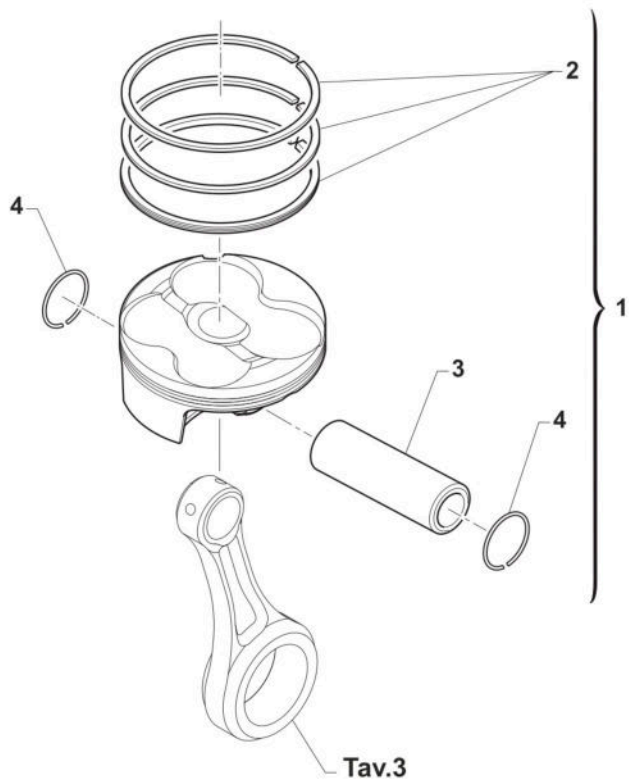

TM0001



**4T300FIMX25**  
**4T 300 Fi MX - 4S 300 Fi MX**

**CILINDRO - PISTONE**  
**CYLINDER - PISTON**

**1**

Pos.	Codice	Q.tà	Note	Descrizione	Description
1	F10868.95	1		PISTONE Ø 80,95 C.19,3 300 4T Fi Twin CPL	PISTON Ø 80,95 C.19,3 300 F.S.TWIN Fi ASSY
1	F10868.96	1		PISTONE Ø 80,96 C.19,3 300 Fi Twin CPL	
1	F10868.97	1		PISTONE Ø 80,97 C.19,3 300 Fi Twin CPL	
1	F10868.98	1		PISTONE Ø 80,98 C.19,3 300 Fi Twin CPL	
2	F11409	1		KIT SEGMENTI D.81 NPR	RINGS KIT D.81 NPR
3	F09396.2	1		SPINOTTO 16X10.5X36 BIC.DLC S2	PISTON PIN 16X10.5X36 DLC
4	F09385	2		ANELLINO D.16X1 VP	CIRCLIP D. 16X1 VP
5	F05859.1	1		HEAD GASKET D. 82 mm 3 LAYERS CH	
6	F26428	2		GRANO RIFERIMENTO 12X13 F10.2	GRUB SCREW 12X13 H.10,2mm
7	F01729	1		Cilindro Ø81 h=34,8 mm 300 REPLICA	
8	F05856.1	1		GUARNIZ.CIL/BAS SP.0,2 EVO3 M3	GASKET CYL. TH.0,2 EVO3 M3
8	F05856.2	1		GUARNIZ.CIL/BAS SP.0,3 EVO3 M3	GASKET CYL. TH.0,3 EVO3 M3
8	F05856.3	1		GUARNIZ.CIL/BAS SP.0,4 EVO3 M3	GASKET CYL TH.0,4 EVO3 M3
8	F05856.4	1		GUARNIZ.CIL/BAS SP.0,5 EVO3 M3	GASKET CYL. TH.0,5 EVO3 M3
9	F49875	2		PRIGIONIERO M6X1 /=83 MM A10.9	STUD M 6X1 83MM
10	F49045	4		PRIGIONIERO M10X1,25 L=142,5	STUD M 10X1,25 142,5 MM
11	F12357.1	2		O RING ORM 91,0X2,0 VITON	
12	49676	2		DADO M 6X1 FLANG. AUTOBL.ACC.	NUT, FLANGED M6 X 1 S.B.

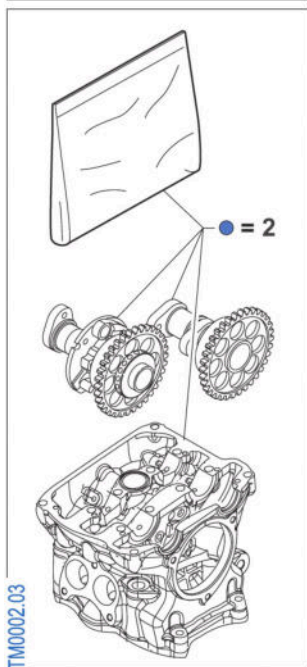
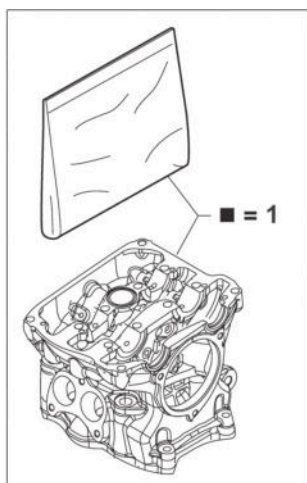

TM0002.03

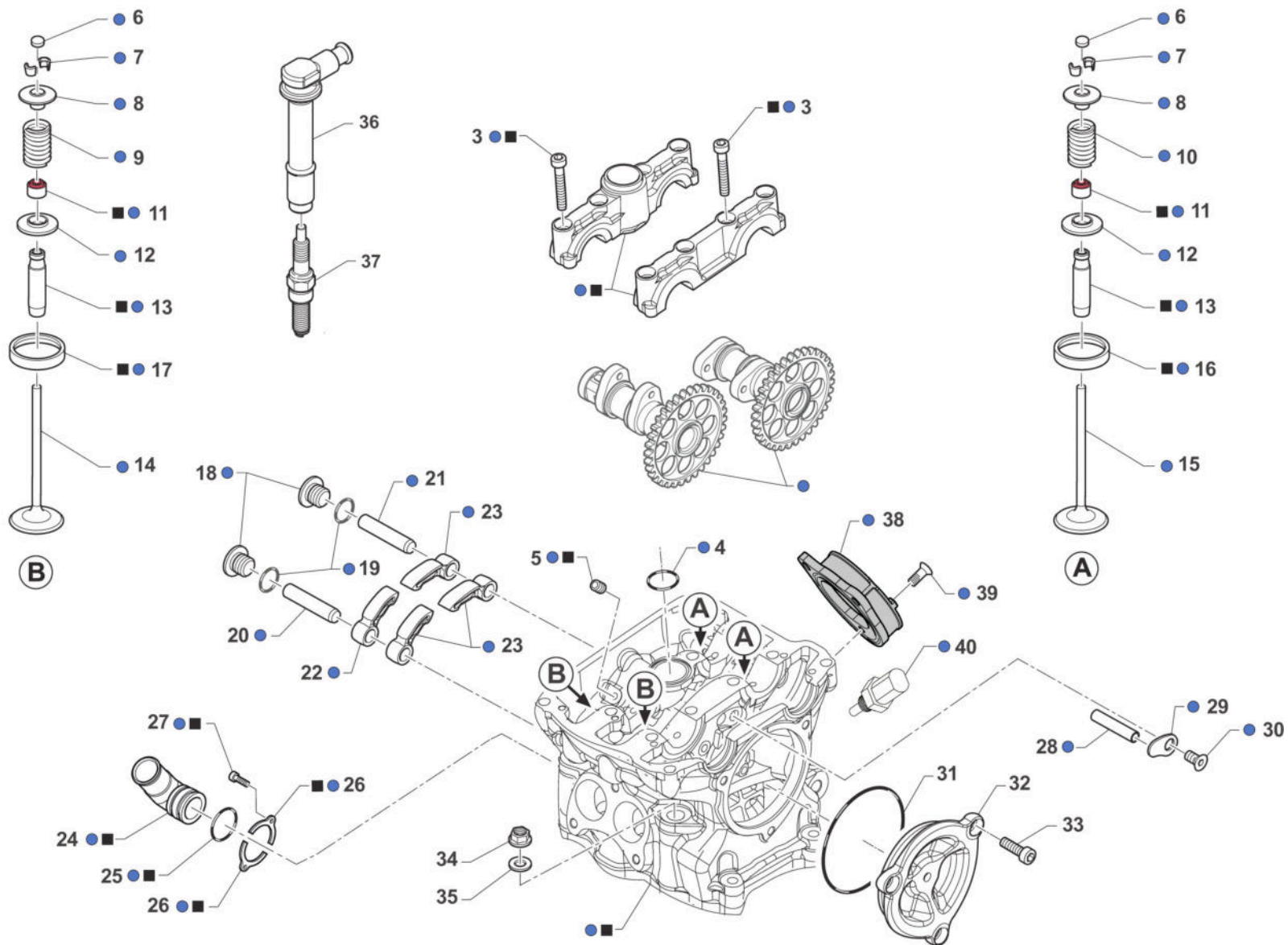



**4T300FIMX25**  
**4T 300 Fi MX - 4S 300 Fi MX**

**TESTA**  
**HEAD**

Pos.	Codice	Q.tà	Note	Descrizione	Description
1	F02886	1		TESTA 4T 250/300 Fi TWIN SEMI-CPL	
2	F02887	1		TESTA 250Fi TWIN MX ES 18/21 CPL 300Fi TWIN MX ES 20/22 CPL	CYLINDER HEAD 250Fi F.S. MX M18->
3	49487.2	8		VITE TCEI 6X35 UNI 5931-912 12.9 BRUNITE	
4	F12345.1	1		O RING ORM 24,0X1,5 VITON	O-RING 24 X 1,5
5	49702	1		GRANO 5X 6 VALV.SC.MARTELLETTO	GRUB SCREW 5 X 6 INLET VALVE
6	F26603.255	1		PASTIGLIA REGOLAZ. GIOCO Ø 7,26 Sp. 2,55	SHIM, VALVE ADJUSTING Ø 7,26 TH. 2,55
6	F26603.260	1		PASTIGLIA REGOLAZ. GIOCO Ø 7,26 Sp. 2,60	SHIM, VALVE ADJUSTING Ø 7,26 TH. 2,60
6	F26603.265	1		PASTIGLIA REGOLAZ. GIOCO Ø 7,26 Sp. 2,65	SHIM, VALVE ADJUSTING Ø 7,26 TH. 2,65
6	F26603.270	1		PASTIGLIA REGOLAZ. GIOCO Ø 7,26 Sp. 2,70	SHIM, VALVE ADJUSTING Ø 7,26 TH. 2,70
6	F26603.275	1		PASTIGLIA REGOLAZ. GIOCO Ø 7,26 Sp. 2,75	SHIM, VALVE ADJUSTING Ø 7,26 TH. 2,75
6	F26603.280	1		PASTIGLIA REGOLAZ. GIOCO Ø 7,26 Sp. 2,80	SHIM, VALVE ADJUSTING Ø 7,26 TH. 2,80
6	F26603.285	1		PASTIGLIA REGOLAZ. GIOCO Ø 7,26 Sp. 2,85	SHIM, VALVE ADJUSTING Ø 7,26 TH. 2,85
6	F26603.290	1		PASTIGLIA REGOLAZ. GIOCO Ø 7,26 Sp. 2,90	SHIM, VALVE ADJUSTING Ø 7,26 TH. 2,90
6	F26603.295	1		PASTIGLIA REGOLAZ.GIOCO Ø 7,26 Sp. 2,95	SHIM, VALVE ADJUSTING Ø 7,26 TH. 2,95
6	F26603.300	1		PASTIGLIA REGOLAZ. GIOCO Ø 7,26 Sp. 3,00	SHIM, VALVE ADJUSTING Ø 7,26 TH. 3,00
6	F26603.305	1		PASTIGLIA REGOLAZ. GIOCO Ø 7,26 Sp. 3,05	SHIM, VALVE ADJUSTING Ø 7,26 TH. 3,05
6	F26603.310	1		PASTIGLIA REGOLAZ. GIOCO Ø 7,26 Sp. 3,10	SHIM, VALVE ADJUSTING Ø 7,26 TH. 3,10
7	F14178	8		SEMICONO D.5 - 15^ HAYFIELD	VALVE RETAINER D.5 15^HAYFIELD
8	F26597	4		PIATTELLO SUP. MOLLA 4T 250/300	UPPER PLATE
9	F16473	2		SET MOLLA EST. + MOLLA INT. SCAR.	EXTER. & INTER.SPRINGS EXHAUST
10	F16472	2		SET MOLLA EST. + MOLLA INT. ASP.	EXTER. & INTER.SPRINGS INLET
11	F04388	4		ANELLO TENUTA STELO VALV.D.5mm SKF	
12	F26689	4		PIATTELLO T 24X4	LOWER PLATE
13	F26728.1	4		GUIDA VALVOLA SINT. D.5 PER TENUTA SKF BLV077	
14	F14158	2		VALVOLA SCA 250Fi 26.8x5 TIT	EXHAUST VALVE 250Fi TIT 26.8X5
15	F14164	2		VALVOLA ASP 250Fi 32x5 TIT	INLET VALVE d.35X5 250Fi TIT
16	F26557	2		SEDE VALVOLA ASP.250cc	



**4T300FIMX25**  
**4T 300 Fi MX - 4S 300 Fi MX**

**TESTA**  
**HEAD**

Pos.	Codice	Q.tà	Note	Descrizione	Description
17	F26558	2		SEDE VALVOLA SCAR.250cc	
18	F49871	2		TAPPO ASSE ROT.BILANC.250 M3	PLUG
19	F12325	2		OR ORM 090-15 FILTRO ASP.OLIO 250N	O-RING
20	F28812	1		ASSE ROTAZIONE BIL.SCAR. 250M3	AXLE, ROCKER ARM EXHAUST
21	F28811	1		ASSE ROTAZIONE BIL.ASP.250M3LO	AXLE, ROCKER ARM INTAKE
22	F28836	1		FINGER FOLLOWER WITH DECOM.MIM	FINGER FOLLOWER WITH DECOM.MIM
23	F28835	3		FINGER FOLLOWER NO DECOMP. MIM	FINGER FOLLOWER NO DECOMP. MIM
24	F28841	1		RACCORDO USCITA ACQUA TESTA	JOINT, HEAD WATER
25	F12346.1	1		O RING ORM 18,0X2,0 VITON	O-RING 18 X 2
26	F48374	2		PIASTRINO RITEGNO RACCORDO H2O	PLATE
27	49553	2		VITE TCEI 4X8 5931-912 Brun	BOLT TCEI 4X8
28	F28810	1		ASSE ROTAZIONE BIL.ASP.250M3LC	AXLE, ROCKER ARM INTAKE
29	F48371	1		PIASTRINO BATT.ASSE ROT.BIL.LC	PLATE
30	49944	1		VITE TS 5X12 TORX	
31	F12351.1	1		O RING ORM 61,6X2,4 VITON	O-RING 61,6 X 2,4
32	F30015	1		COPERCHIO ISP. TESTA 250Fi 250 REP.4T	COVER, HEAD, TWIN
33	49481	3		VITE TCEI 6X12	BOLT TCEI 6X12
34	F49874	4		DADO M 10 X 1,25 CH 12 FLANGIATO	NUT FLANGED M 10x1,25 T.12mm
35	F48400	4		RONDELLA Ø10xØ17,5x3	WASHER Ø10xØ17,5x3
36	F21436	1		PIPETTA CANDELA RESISTIVA 250 4T MY18->	CAP, SPARK PLUG
37	F06116	1		CANDELA NGK R0451B-8	SPARK PLUG NGK R0451B-8
38	F13287	1		COLLETTORE ASPIRAZIONE 250Fi 4T REPL.	INLET MANIFOLD 250Fi F.S. R.
39	49989	3		VITE TS 5X14 TORX	BOLT TORX 5 X 14
40	F08003	1		SENSORE TEMP. ACQUA 4T	SENSOR, WATER TEMPERATURE





4T300FIMX25  
4T 300 Fi MX - 4S 300 Fi MX

ALBERO MOTORE  
CRANKSHAFT

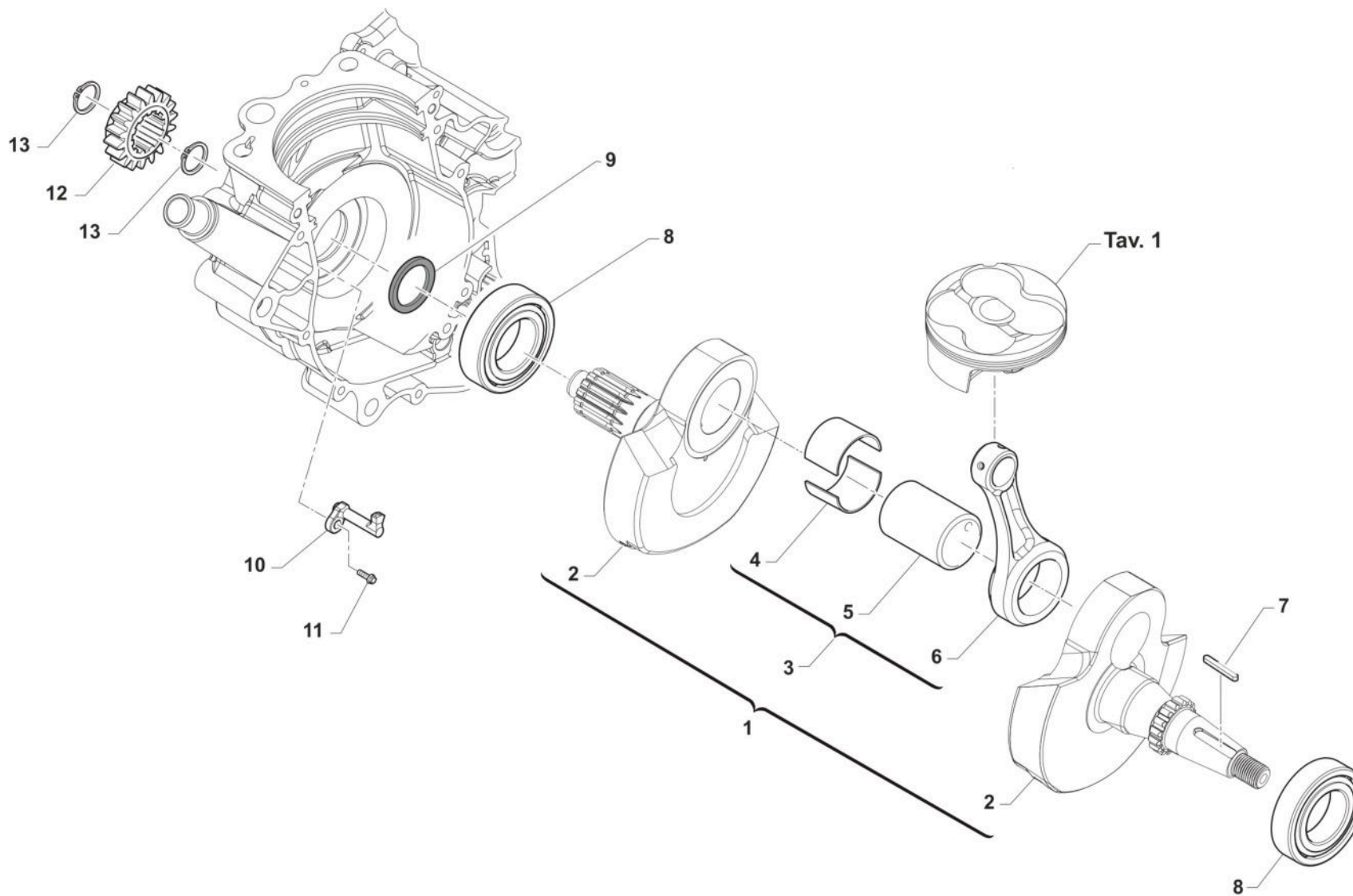

TM 0003.03



4T300FIMX25  
4T 300 Fi MX - 4S 300 Fi MX

ALBERO MOTORE  
CRANKSHAFT

3

Pos.	Codice	Q.tà	Note	Descrizione	Description
1	F18125	1		ALBERO MOTORE 300 FI E.S. 2020 CPL	
2	F18127	1		COPPIA SEMI ALBERI 300 FI E.S. 2020	
3	F18123	1		BIELLA 300FI REPLICA MX/EN CPL (D.34XD.17,8 INTERASSE 98,5)	
4	F03375.4	1		BRONZINA CP BIELLA 30X34X18 BB BLU/BLU	CONNECTING ROD BUSH ASSY 30x34x18 blu
4	F03375.5	1		BRONZINA CP BIELLA 30X34X18 RG ROSSO/GIALLO	BUSH ASSY 30x34x18 RED/YELLOW
5	F18059	1		ASSE ACCOPP. D.30X54,7 X BRONZ	
6	F18104	1		BIELLA D34XD.16 I.98,5 BR	
7	F49853	1		CHIAVETTA 5X3X25 UNI7510R.F.A.	WOODRUFF KEY, 5x3x25
8	03026	2		CUSCINETTO ALBERO MOTORE NJ206	BUSH, NJ206 CRANKSHAFT
9	F04375	1		PARAOLIO 25X35X4	
10	F32573	1		UGELLO RAFFREDDAMENTO	NOZZLE
11	49472	1		VITE TCEI 5X12 UNI 5931-912 Brun	BOLT TCEI 5X12
12	F40158	1		PIGNONE TRASM.PRIMARIA Z20 SCANAL.	
13	49255	2		SEEGER RETTIFICATO CAMBIO 250	CIRCLIP, GEAR BOX 250cc

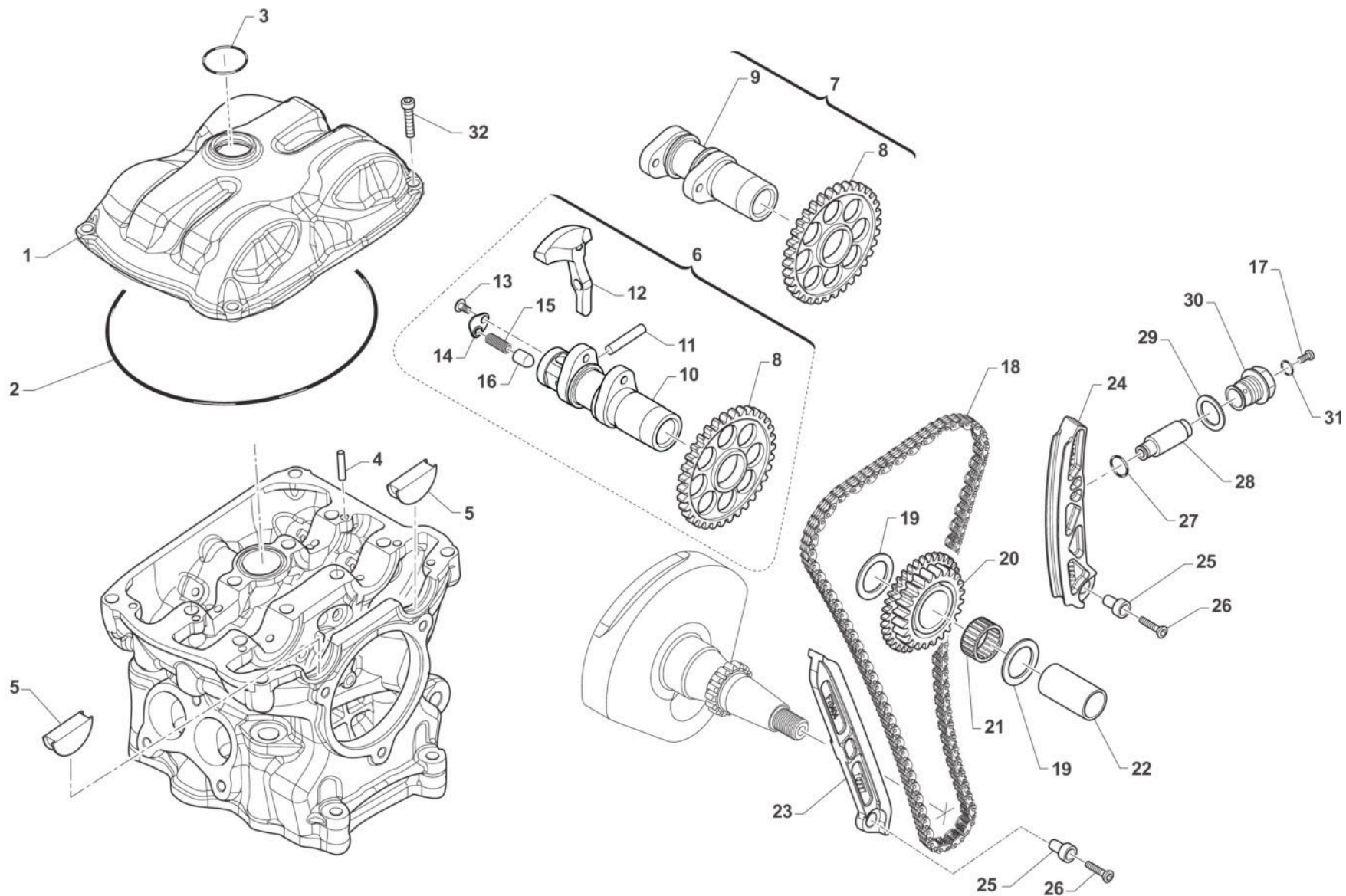

TM0004.01



**4T300FIMX25**  
**4T 300 Fi MX - 4S 300 Fi MX**

**DISTRIBUZIONE**  
**DISTRIBUTION**

**4**

Pos.	Codice	Q.tà	Note	Descrizione	Description
1	F30061	8		COPERCHIO TESTA 250Fi MX MY18	CYLINDER HEAD COVER 250Fi F.S. MX M18->
2	F12364	1		O RING 155X2	O-RING 155 X 2
3	F12344.1	1		O RING ORM 23,0X1,5 VITON	O-RING 23 X 1,5
4	F19529	4		RULLO D.4 X 10 TESTA BOMBATA" NRA"	PIN 4 X 10
5	F30060	2		COPERC.TTO FORI A.CAMME250/300	CAP, HOLE CAMSHAFT 250/300
6	F28852	1		ALBERO A CAMME SCARICO 250Fi MX ES + EN CPL	CAMSHAFT ASSY, EX, 250 MX ES + EN
7	F28846	1		ALBERO A CAMME ASPIRAZIONE 250Fi MX 2018 CPL	
8	F40062	2		INGR. ALBERO A CAMME GEN. Z28	GEAR 28T, CAMSHAFT
9	F28807	1		ALBERO A CAMME ASP. EVO3 XA-18	
10	F28809	1		ALBERO A CAMME SCAR.EVO3 XS-04	CAMSHAFT EX XS-04
11	F19530	1		RULLO D.5 X 19.8 G2 0 -0.010	PIN 5 X 19,8
12	F26575	1		DECOMPRESSORE (MASSA CENT.) 4T 250/300 TWIN	DECOMPRESSOR
13	49597	1		VITE TBCEI 4 x 8 UNI 7380	BOLT TBCE 4 x 8
14	F48368	1		PIASTRINO GUIDA MOLLA DECOMPR.	PLATE DECOMPRESSOR SPRING 250 F.S.
15	F16479	1		MOLLA DECOMP. FILO Ø 0,3 250/300 4T TWIN	SPRING
16	F26576	1		PISTONCINO ATTIVAZIONE DECOMP.	PISTON DECOMPRESSOR
17	F49871	1		TAPPO ASSE ROT.BILANC.250 M3	PLUG
18	F70423	1		CATENA DIST.MORSE 92RH2015 92P 300 TWIN	CAM CHAIN 92RH2015 92 300 TWIN
19	F48372	2		RASAMENTO 18 x 30 x 0.8	SHIM 18 X 30 X 0,8
20	F40061	1		INGR. DOPPIO DISTRIBUZ.24/21	GEAR 24/21T DISTRIBUTION
21	F19526	1		GABBIA A RULLINI K 18X22X17	NEEDLE BUSH 18x22x17
22	F28813	1		ASSE ROTAZIONE INTR.18X42,7F13	PIN ROTATION GEAR 18x42,7 H.13
23	F70404	1		PATTINO FISSO 4T 250/300 TWIN	FIXED SLIDER
24	F70413	1		PATTINO MOBILE 4T 250/300 TWIN	MOVING SLIDER
25	F49883	2		BOCCOLA FISS. PATT.MOB. F70402	BUSH
26	49168	2		VITE TSEI 6X22	
27	F12346.1	1		O RING ORM 18,0X2,0 VITON	O-RING 18 X 2



**4T300FIMX25**  
**4T 300 Fi MX - 4S 300 Fi MX**

**DISTRIBUZIONE**  
**DISTRIBUTION**

**4**

Pos.	Codice	Q.tà	Note	Descrizione	Description
28	F70408	1		TENDITORE IDRAULICO 250 M3 F-346264.89-0100.KSH.KSYS	HYDRAULIC TENSIONER 250Fi M3
29	49949	1		RONDELLA RAME 24X30X1,5	WASHER, COPPER, 24 X 30 X 1,5
30	F49884	1		TAPPO TENSIONATORE IDR. M3	PLUG, TENSIONER
31	F12356.1	1		O RING ORM 10,0X1,0 VITON	O-RING 10 X 1
32	49483	4		VITE TCEI 6X16 UNI 5931	BOLT TCEI 6X16



4T300FIMX25  
4T 300 Fi MX - 4S 300 Fi MX

LUBRIFICAZIONE  
LUBRICATION

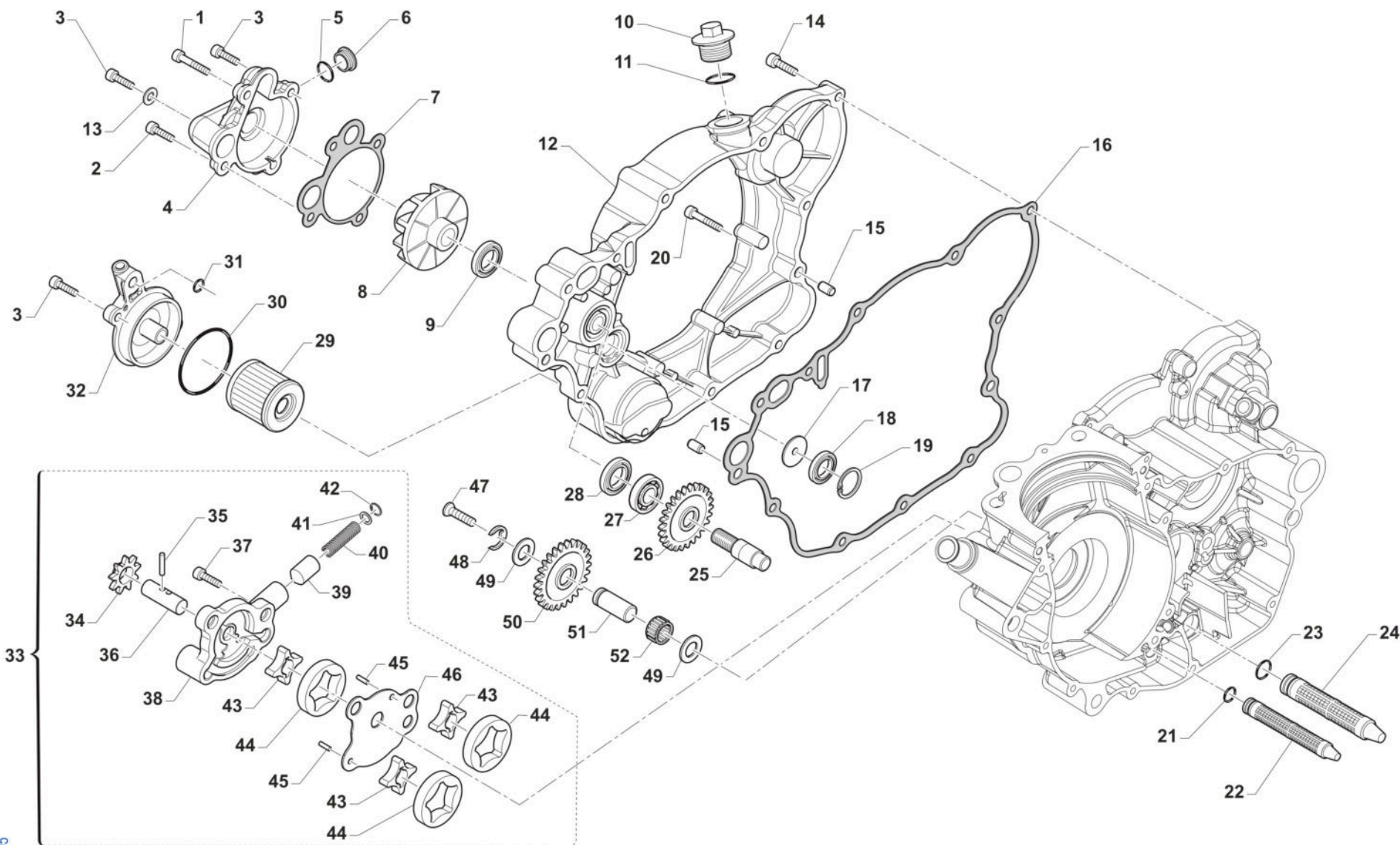

TM0005



**4T300FIMX25**  
**4T 300 Fi MX - 4S 300 Fi MX**

**LUBRIFICAZIONE**  
**LUBRICATION**

Pos.	Codice	Q.tà	Note	Descrizione	Description
1	49575	1		VITE TCEI 5X45 UNI 5931	BOLT TCEI 5X45
2	49570	1		VITE TCEI 5X50 UNI 5931	SCREW TCEI 5X50
3	49476	3		VITE TCEI 5X20 UNI 5931	BOLT TCEI 5X20
4	F30966	1		COPERCHIO POMPA H2O 250Fi 11/-	COVER, WATER PUMP 250Fi M.2011
5	F12327	1		O RING COPERCHIO P.ACQUA 250N	O-RING COVER WATER PUMP 250 4S
6	F49841	1		TAPPO COP. POMPA H2O 250Fi	CAP, COVER WATER PUMP 250 4S
7	F05833	1		GUARNIZ.COP.POMPA ACQUA.250N	GASKET, H2O COVER 250Fi
8	F28679	1		GIRANTE POMPA ACQUA 250N	IMPELLER, H2O PUMP 250Fi
9	04017	1		PARAOLIO CENTRIFUGA 06	OIL SEAL 8 X 22 X 7 TC
10	F49925	1		TAPPO CARICO OLIO M20X1.5	OIL PLUG M20X1,5
11	F49920	1		RONDELLA ALL 20.4X26X1.5	WASHER 20,4X26X1,5 ALUM.
12	F30961	1		COPERCHIO TRAS. PRIM. 250N '11	COVER, PRIMARY DRIVE 250N 11->
13	49119	1		RONDELLA 5 x 9 x 1,5 ALLUMINIO	WASHER, 5 x 9 x 1.5 ALLUMINIUM
14	49477	7		VITE TCEI 5X25 UNI 5931-912	BOLT TCEI 5X25
15	26041	2		GRANO CENTRAGGIO D.7X8 F.5,2	DOWEL PIN 7 x 8 Hole 5,2
16	F05828	1		GUARNIZ.COP.TRASM.PRIMAR.250N	GASKET, CLUTCH CASE 250Fi
17	F32529	1		DISCHETTO PARZIAL. MAND.OLIO 250N	DISC OIL PUMP 250 F.S.
18	F04390	1		PARAOLIO FAJ 14-22-5 HS	OIL SEAL FAJ 14-22-5 HS
19	F49913	1		SEEGER I 23	CIRCLIP INT. 23
20	49478	1		VITE TCEI 5X30 UNI 5931	BOLT TCEI 5X30
21	F12325	1		OR ORM 090-15 FILTRO ASP.OLIO 250N	O-RING
22	F32532	1		FILTRO ASPIRAZ.POMPE OLIO 250N	FILTER, OIL, 250Fi
23	F12343	1		O RING FILTRO OLIO 250F	O-RING
24	F32555	1		FILTRO ASPIRAZIONE OLIO MAGG.	FILTER OIL INLET
25	F28658	1		ALBERINO POMPA H2O 250N	SHAFT, WATER PUMP 250Fi
26	F40112	1		INGRANAGGIO COND.P.ACQUA Z 21 300 4T	
27	F03365	1		CUSCINETTO POMPA ACQUA 250/09	BEARING WATER PUMP 250/09
28	F04363	1		PARAOLIO 8X22X5 250/09->	OIL SEAL 8x22x5 (250F/09)



**4T300FIMX25**  
**4T 300 Fi MX - 4S 300 Fi MX**

**LUBRIFICAZIONE**  
**LUBRICATION**

Pos.	Codice	Q.tà	Note	Descrizione	Description
29	F66510	1		FILTRO OLIO 4Tempi HF 141	OIL FILTER HF - 141
30	12094	1		O RING COP. FILTRO OLIO	O RING OIL FILTER COVER
31	F12302	1		O RING 108 PIOGGIA CAMBIO 4T	O-RING, 108 GEAR F.S.
32	F30965	1		COPERCHIO FILTRO OLIO 250Fi 11	CAP, OIL FILTER 250Fi 11->
33	F30068	1		POMPA OLIO COMPLETA 250/300 Fi TWIN	OIL PUMP ASSY
34	F40997	1		INGRANAGGIO POMPA OLIO 250Fi Z 9	GEAR, OIL PUMP 250Fi 9 T
35	F19513	3		RULLINO ING. POMPA 250/09	PIN, PUMP GEAR 250 09->
36	F28840	1		ALBERINO POM.OLIO RO.H10/2XH10	SHAFT, OIL PUMP
37	49751	2		VITE TCEI 5X22	BOLT TCEI 5 X 22
38	F30059	1		CORPO POMPA	OIL PUMP BODY
39	F32533	1		PIST.NE VALV.LIMIT.PRESS.OLIO	PISTON
40	F16441	1		MOLLA VALVOLA PRESS.OLIO 250N	SPRING
41	49600	1		RONDELLA 4x8x0,8	WASHER 4
42	49267	1		SEEGER 8mm INT Sp. 0,8	SEEGER
43	F32577	3		ROTORE INTERNO POMPA OLIO 250Fi	ROTOR, OIL PUMP, INTERNAL
44	F32578	3		ROTORE ESTERNO POMPA OLIO 250Fi	ROTOR, OIL PUMP, EXTERNAL
45	F19521	2		RULLINO D.3 X 11	PIN 3 X 11
46	F32574	1		SEPARATORE POMPA OLIO	PLATE
47	49429	1		VITE TSEI 4X35	BOLT TSEI 4X35
48	F49821	1		ANELLO ELASTICO RA 7 ING. FOLLE P.OLIO 250/09	SEEGER INTER.GEAR OIL P.250 4S
49	F19512	2		RALLA ING.FOLLE P. OLIO 250/09	THRUST WASHER
50	F40909	1		INGR. OZIOSO POMPA OLIO 250N	GEAR, OIL PUMP
51	F28665	1		ALBERINO ING.FOLLE P.OLIO 250N	SHAFT
52	F19511	1		GABBIA RULLI ING.F.P.OL.250/09	NEEDLE CAGE GEAR 250F 09->





4T300FIMX25  
4T 300 Fi MX - 4S 300 Fi MX

CARTER MOTORE  
CLUTCH CASE

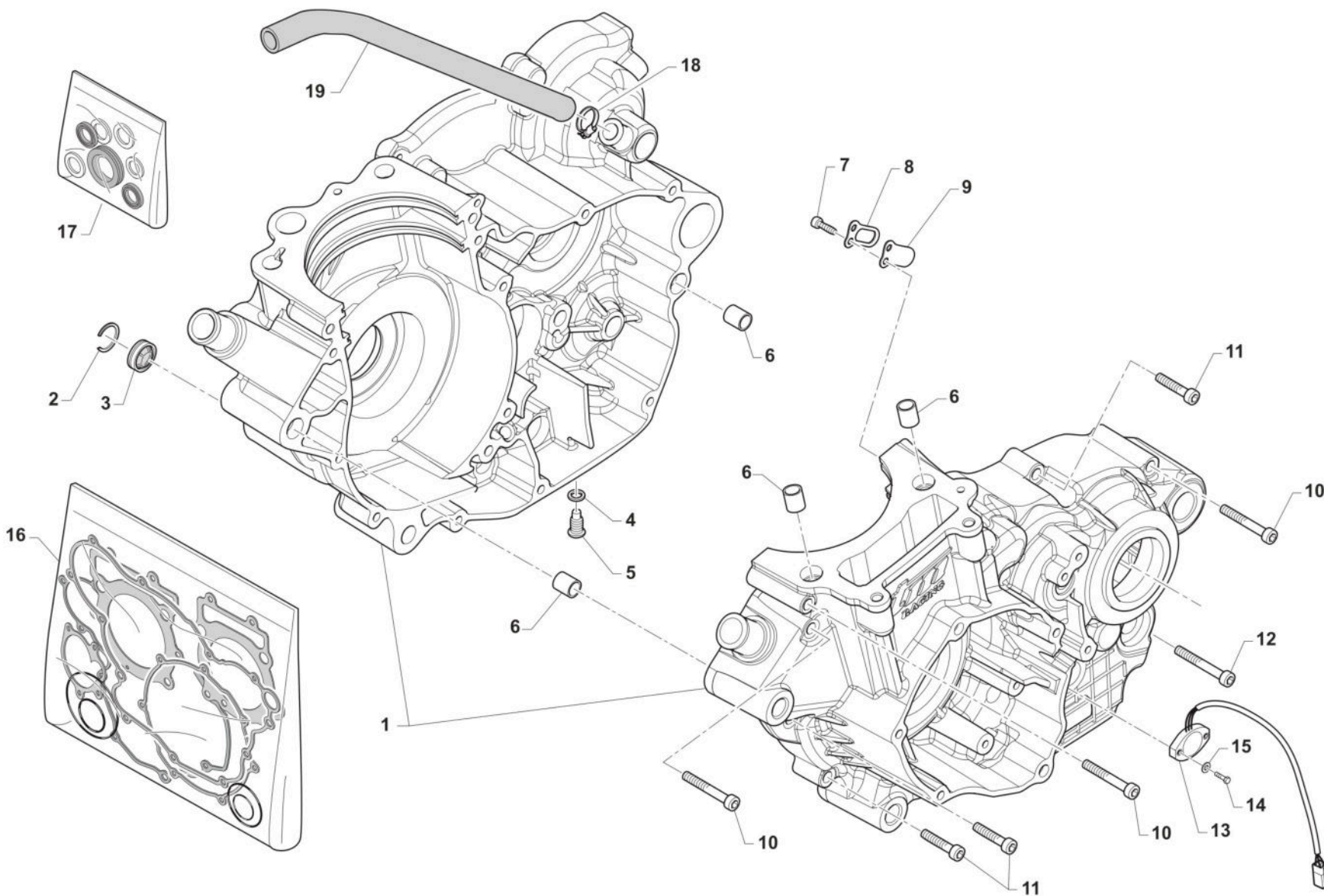

TM 0006.01



**4T300FIMX25**  
**4T 300 Fi MX - 4S 300 Fi MX**

**CARTER MOTORE**  
**CLUTCH CASE**

Pos.	Codice	Q.tà	Note	Descrizione	Description
1	F30076	1		BASAMENTO MOT. 300Fi ES TWIN 20	
2	F49832	1		SEEGER SB25 OBLO' 250Fi 10/->	SEEGER
3	F04366	1		OBLO' LIVELLO OLIO DIAM.25 MM	OIL LEVEL INSPECTION SIGHT GLASS
4	49125.1	2		RONDELLA RAME 12X18X1,5	
5	F49820.1	2		TAPPO OLIO C/CALAM. 250Fi	OIL PLUG WITH MAGNET 250Fi
6	F26428	4		GRANO RIFERIMENTO 12X13 F10.2	GRUB SCREW 12X13 H.10,2mm
7	49542	1		VITE TCEI 5X10 UNI 5931	BOLT TCEI 5 X 10
8	F20004	1		STOPPER LAMELL.CAMERA ALB.250N	STOPPER, STOP
9	F20003	1		LAMELLA SFIATO PRESS.250Fi	REED
10	49491	3		VITE TCEI 6X55	BOLT TCEI 6X55
11	49487	4		VITE TCEI 6X35 UNI 5931	BOLT TCEI 6X35
12	49492	1		VITE TCEI 6X60	BOLT TCEI 6X60
13	F08456	1		SENSORE POSIZIONE CAMBIO eM060 CPL G.ORARIO (SOSTITUISCE F08236.1)	
14	49922	2		VITE TE 3X14	
15	49926	2		RONDELLA 3X9X1	WASHER 3 X 9 X 1
16	F05864	1		KIT GUARNIZIONI 300Fi EN/MX MY20 REPLICA	GASKETS 300FI EN7MX MY20->
17	04043	1		KIT PARAOLI 4T 250/300Fi TWIN MY2022	
18	51073	1		FASCETTA 10/19	CLAMP 10 / 19 mm
19	F65104	1		TUBO COPOLAN GRIGIO 11x16	HOSE COPOLAN GREY 11X16mm



4T300FIMX25  
4T 300 Fi MX - 4S 300 Fi MX

# FRIZIONE CLUTCH

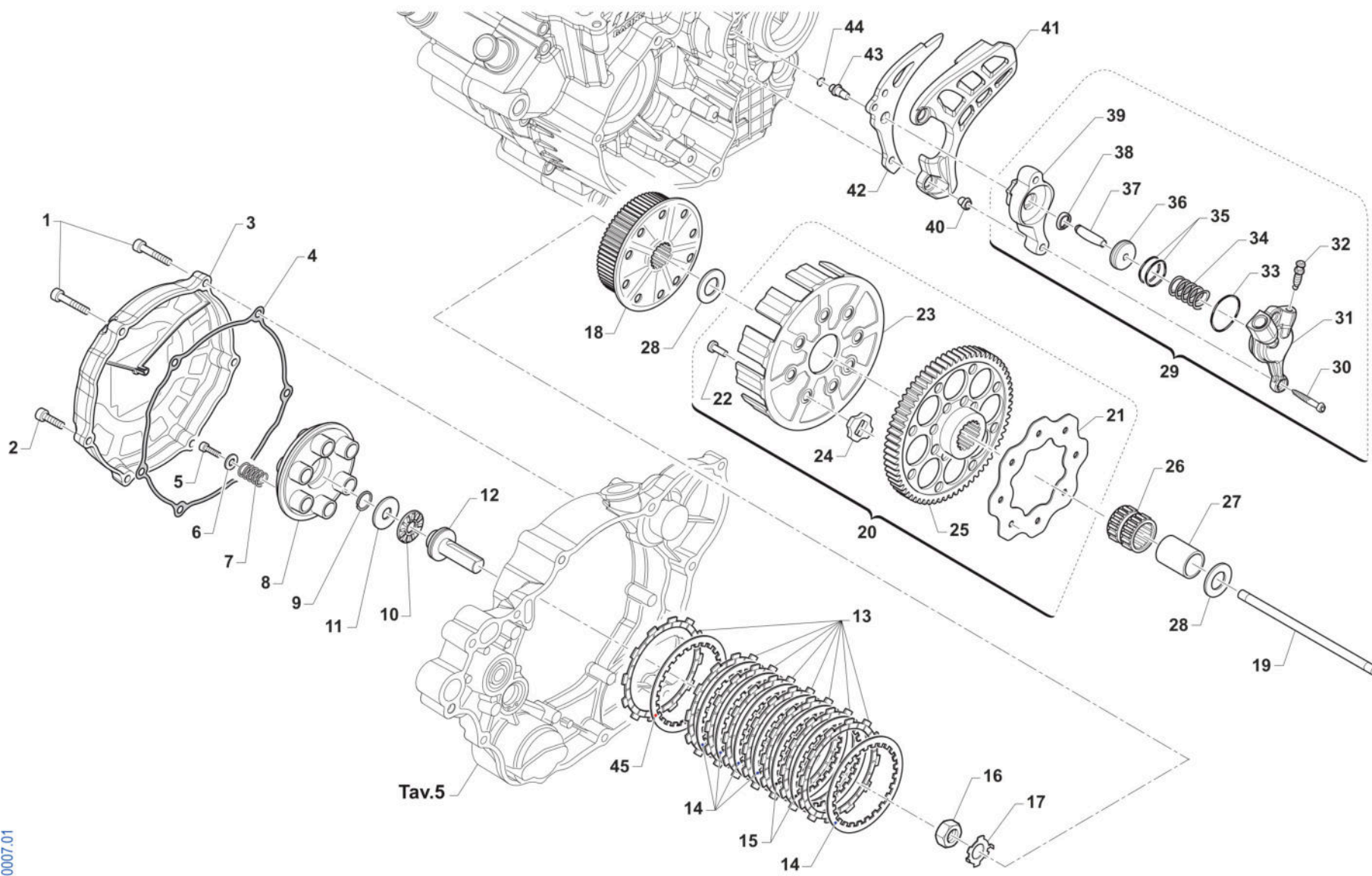

TM 0007.01



4T300FIMX25  
4T 300 Fi MX - 4S 300 Fi MX

FRIZIONE  
CLUTCH

7

Pos.	Codice	Q.tà	Note	Descrizione	Description
1	49736	2		VITE TCEI 5X65	BOLT TCEI 5X65
2	49477	4		VITE TCEI 5X25 UNI 5931-912	BOLT TCEI 5X25
3	F30960	1		COPERCHIETTO FRIZ.250Fi M.11->	COVER, CLUTCH 250Fi M. 11/->
4	F05841	1		GUARN. COP. FRIZ. 250Fi 2011	GASKET, CLUTCH COV 250Fi 11/->
5	49484	6		VITE TCEI 6X20	BOLT TCEI 6X20
6	49604	6		RONDELLA 6 X18 X 1,6	WASHER 6x18
7	F16453	6		MOLLA FRIZIONE 2/4T 250/450	SPRING, CLUTCH 2/4T 250/450
8	F25258	1		PIATTO SPINGIDISCHI 250Fi	PRESSURE PLATE, CLUTCH 250Fi
9	09006	1		ANELLINO FERMA SPINOTTO 80/85/100	CLIP, PISTON PIN 80/85/100cc
10	19022	1		GABBIA A RULLI RAD. AXK 1528	BUSH CAGE AXK 1528, RADIAL
11	19023	1		RONDELLA GABBIA RULLI AS 1528	WASHER, NEEDLE CAGE AS 1528
12	F35582	1		FUNGO FRIZIONE IDRAULICA 2015	PIECE, CLUTCH LIFTER
13	F35588	8		DISCO FRIZIONE 4T 250/300 Fi FCC	CLUTCH PLATE, FIBER 250Fi 4S
14	35070	5		DISCO FRIZ. ACC 1,2 mm 4T 250/300 C67	
15	F35596	2		DISCO FRIZ. ACC 1,8 mm 250Fi	CLUTCH DISC STEEL 1,8 mm 250Fi
16	49060	1		DADO TAMBUR.FRIZ. ALB.PRIM. 250/300 M18X1.5	NUT, CLUTCH CENTER 250cc
17	35050	1		RONDELLA X FRIZ. 250/300/4T	CLUTCH WASHER 250/300/F
18	F25256	1		TAMBURELLO FRIZ.250F -N-	CLUTCH CENTER 250Fi
19	F35544	1		ASTINA CENTRAL.FRIZ.192mm 250N	ROD, CLUTCH 192mm 250N
20	F40159	1		COPPIA PRIMARIA CPL 300Fi Z 59/18	
21	35262	1		DISCO BATTUTA GOMMINI FRIZ. 2T/4T F.6 MM	PLATE, CLUTCH BASKET 250cc
22	49202	8		CHiodo FRIZIONE K3/KV/K7 D 5,8	PIN CLUTCH K3/KV/K7/K8/K9
23	F25257	1		CAMPANA FRIZ. 250Fi	CLUTCH BASKET 250Fi M. 10/->
24	21005	8		GOMMINO PARASTRAPPI FRIZIONE	RUBBER, CLUTCH BASKET
25	F40114	1		CORONA TRAS.PRIMARIA Z 59/18 300 4T	
26	F19510	1		GABBIA A RULLINI K 27X32X23.8	NEEDLE CAGE 27 x 32 x 23.8
27	F26422	1		BOCCOLA INGR.TRASM.PRIM. 250N	BUSH, PRIMARY GEAR 250Fi
28	48250	2		SPESSORE COPPIA PRIMARIA 250	SPACER, PRIMARY GEAR 250cc



4T300FIMX25  
4T 300 Fi MX - 4S 300 Fi MX

FRIZIONE  
CLUTCH

7

Pos.	Codice	Q.tà	Note	Descrizione	Description
29	F30005	1		COP. FRIZ/IDR 4T 250N D.26 CPL	COVER, IDR/CLUTCH 4S 250N ASSY
30	49535	2		VITE TCEI 5X35 UNI 5931-912 Brun	BOLT TCEI 5X35
31	F30006	1		CORPO CILIN. FRIZ. 250Fi D.26	BODY CLUTCH CYLINDER 250Fi D26
32	35264	1		VITE SPURGO OLIO FRIZ.IDR.6X1	SCREW AIR BLEED HYDRAUL.CLUTCH
33	12252	1		O RING PIGNONE CAT.+DIS.AL.MOT	O-RING, 25,12 x 1,78
34	F16445	1		MOLLA PIST. FRIZ. 250N	SPRING
35	12259	2		O RING PISTONE FR.125/250 VITON (Verde)	O-RING, CLUTCH PISTON 125/250
36	F35522	1		PISTONE CILINDRETTO 250N D.26	PISTON CLUTCH CYLINDER 250F 26
37	F19518	1		RULLO D.S. 5 X 24	PIN 5 X 24
38	F04367	1		PARAOLIO 9X13X3	OIL SEAL 9X13X3
39	F35523	1		DISTANZIALE CILINDRETTO 250N	SPACER CYLINDER 250N
40	26211	2		BOCCOLA PROT. PIGNONE 250 F.5	COLLAR, SPROCKET 250cc H.5
41	F30944	1		PROTEZIONE PIGNONE 250Fi PLAST	SPROCKET PROTECTION 250 F.I. PLAST.
42	F70370	1		PROTEZ. ERGAL PIGN. CAT 250N	PROTECTION, ALUMINIUM, FRONT SPROCKET
43	F26460	1		DIST.CENTR.SUPP.ATT.FRIZ.250N	SPACER
44	F12302	1		O RING 108 PIOGGIA CAMBIO 4T	O-RING, 108 GEAR F.S.
45	F35596	2		DISCO FRIZ. ACC 1,8 mm 250Fi	CLUTCH DISC STEEL 1,8 mm 250Fi



4T300FIMX25  
4T 300 Fi MX - 4S 300 Fi MX

# COMANDO CAMBIO GEARSHIFT MECHANISM

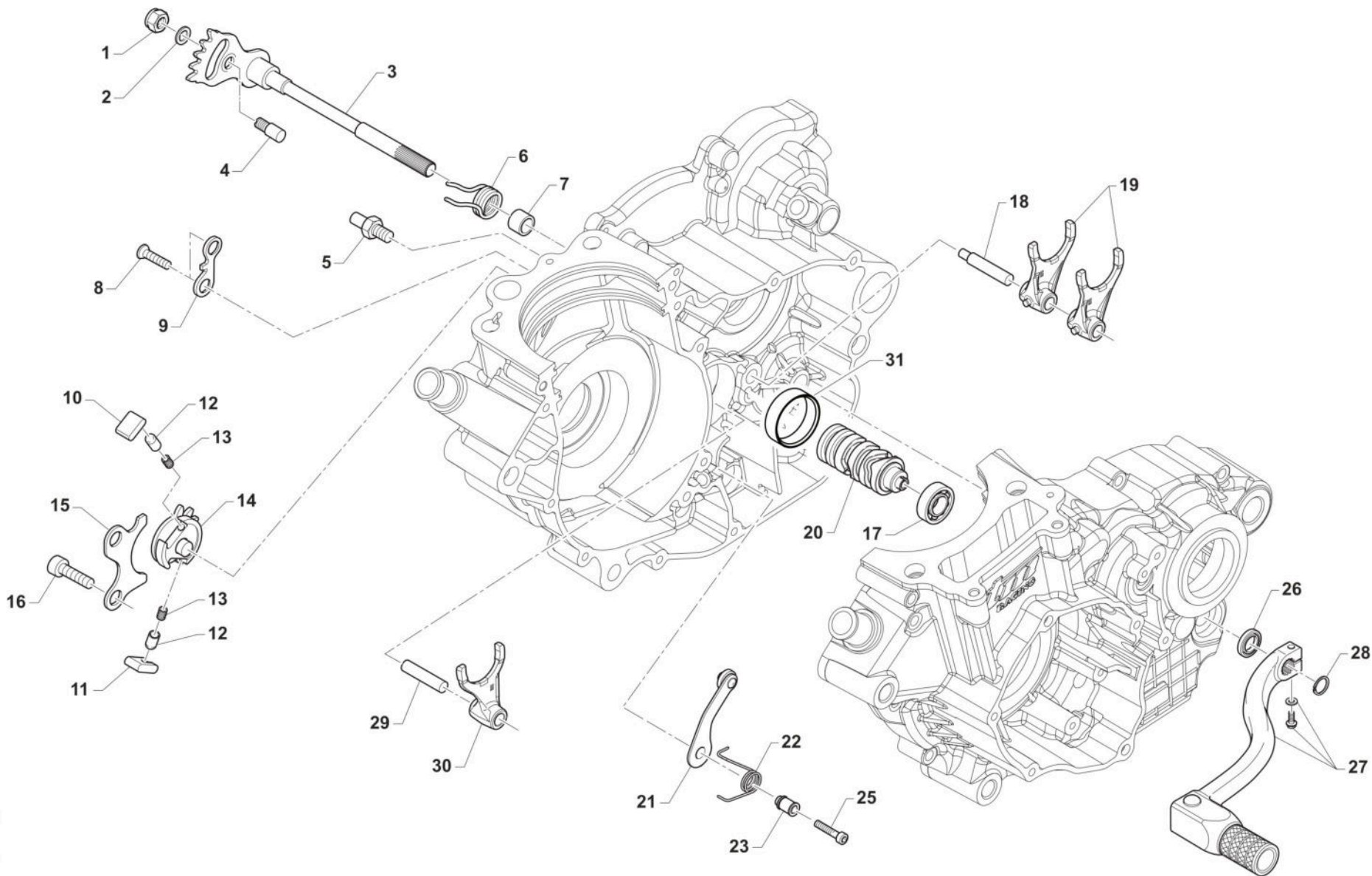

TM 0008.01



**4T300FIMX25**  
**4T 300 Fi MX - 4S 300 Fi MX**

**COMANDO CAMBIO**  
**GEARSHIFT MECHANISM**

Pos.	Codice	Q.tà	Note	Descrizione	Description
1	49638	1		DADO M 6 ALTO AUTOBLOCCANTE	NUT 6mm, HIGHT SELF-LOCKING
2	49603	1		RONDELLA M 6,4 X 12 X 1,6	WASHER 6x12
3	26050	1		BATTUTA ECCENTRICA	ADJUSTER SELECTOR SHAFT
4	28100	1		ALBERO COMANDO ING. P.TACRIC.	SHAFT, GEARSHIFT
5	F26455	1		BATTUTA FISSA MAN.CAMBIO 250N	
6	16010	1		MOLLA RITORNO LEVA CAMBIO 3	SPRING, RETURN GEAR LEVER 3mm
7	26006	1		DISTANZIALE MOLLA LEVA CAMBIO	SPACER, GEAR LEVER SPRING
8	49404U	2		VITE TSEI 6X16 UMBRAKO	BOLT TSEI 6X16 UMBR.
9	F26454	1		PIASTR.FINECORSO CRIC. 250N	PLATE, ENDSTROKE RATCHET 250N
10	26060	1		CRICCHETTO CAMBIO SUPERIORE	RATCHET UP, GEAR
11	26061	1		CRICCHETTO CAMBIO INFERIORE	RATCHET DOWN, GEAR
12	26062	2		PUNTALE PER CRICCHETTO CAMBIO	PIN, RATCHET GEAR
13	16012	2		MOLLA PER PUNTALE	SPRING, GEARBOX PIN
14	40310	1		INGRANAGGIO PORTACRICCHETTI	DRUM SHIFTER GEAR
15	26021	1		PIASTRINO RIENTRO CRICCHETTI	PLATE, RATCHET
16	49483	2		VITE TCEI 6X16 UNI 5931	BOLT TCEI 6X16
17	03012	1		CUSCINETTO DESMODROMICO 6001 2RS	BUSH, 6001 2RS GEAR DRUM
18	33256	1		PERNO FORCH.ALB.SEC. 250 / 125.99	AXEL, COUNTERSHAFT FORK 250cc
19	F33312	2		FORCHETTA A/S 250Fi CROMATA	SHIFT FORK COUNTERSHAFT 250 4S
20	F33353.1	1	PER CAMBIO 6M	DESMODROMICO 250-300 4T 6M. PR.4	
21	26095	1		PIASTRINO BLOCCAMARCE KV/95CPL + MOTO	PLATE, STOP GEAR KV/95 ASSY
22	F16447.3	1		MOLLA BLOCCA MARCE 250 4T D.FILO 2.4	
23	26007	1		DISTANZIALE MOLLA BLOCCAMARCE	SPACER, STOP GEAR SPRING
25	49485	1		VITE TCEI 6X25 UNI 5931	BOLT TCEI 6x25
26	04004	1		PARAOLIO POMPA H2O-LEVA CAMBIO	OIL SEAL 12 x 22 x 5
27	43050	1		LEVA CAMBIO 4T MY22 [ 587 ]	
28	49212	1		SEEGER E12 LEVA CAMBIO	CIRCLIP D.12 - EXTERNAL
29	33255	1		PERNO FORCH.ALB. PRIM.250 / 125.99	AXEL, MAINSHAFT FORK 250cc



4T300FIMX25

4T 300 Fi MX - 4S 300 Fi MX

COMANDO CAMBIO

GEARSHIFT MECHANISM

8

Pos.	Codice	Q.tà	Note	Descrizione	Description
30	F33311	1		FORCHETTA A/P 250Fi CROMATA	FORK, MAIN SHAFT 250Fi
31	19041	1		ASTUCCIO A RULLI DHK 35/12	BUSH NEEDLE CAGE DHK 35/12





4T300FIMX25  
4T 300 Fi MX - 4S 300 Fi MX

CAMBIO  
GEAR BOX

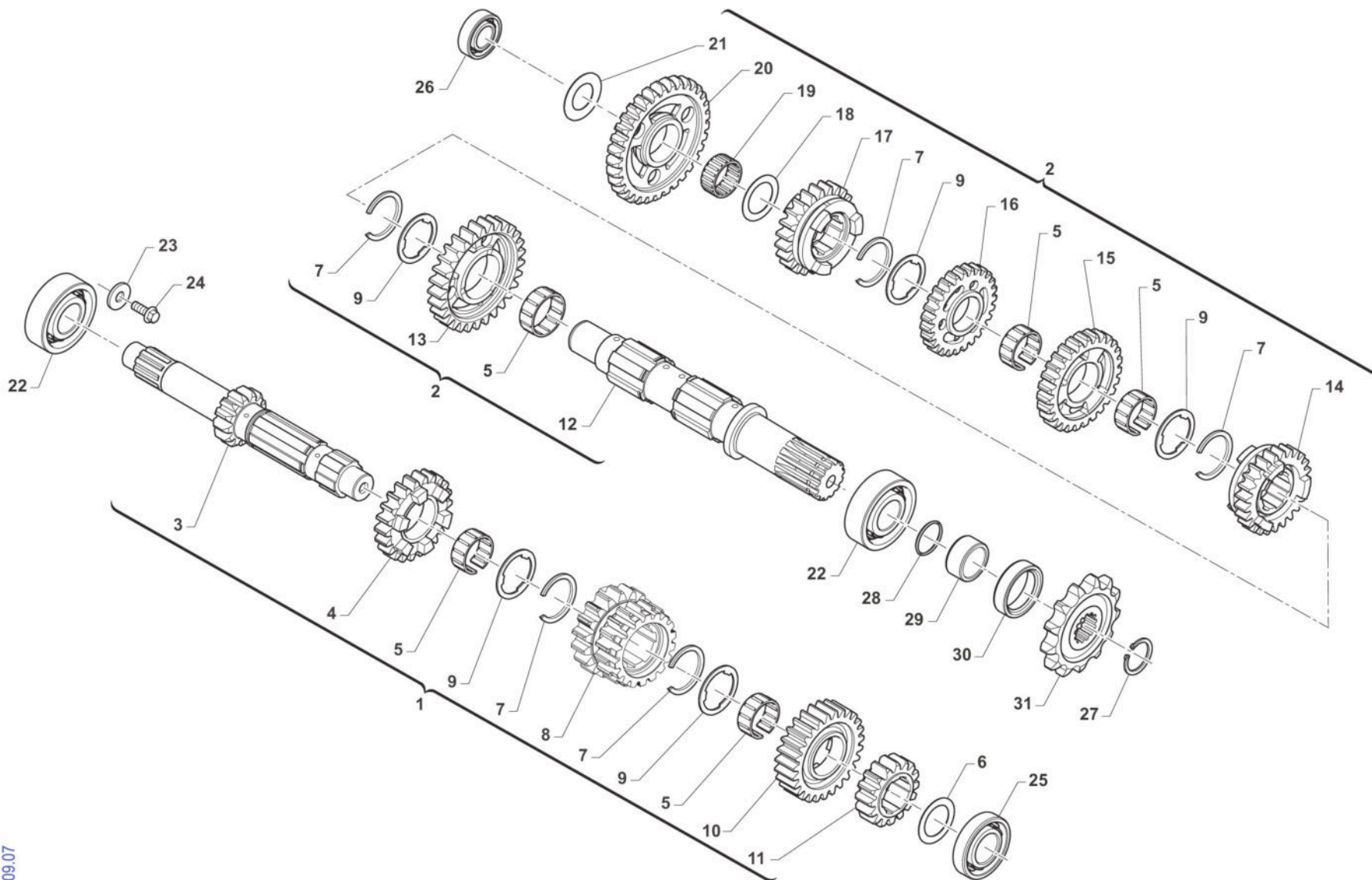

TM0009.07



4T300FIMX25  
4T 300 Fi MX - 4S 300 Fi MX

CAMBIO  
GEAR BOX

9

Pos.	Codice	Q.tà	Note	Descrizione	Description
1	F40240	1		ALBERO PRIMARIO 300Fi MX 23 4T (6 ALETTE) CPL	
2	F40241	1		ALBERO SECONDARIO 300Fi MX 23 4T (6 ALETTE) CPL	
3	F40215	1		ALBERO PRIMARIO Z 13 6 ALETTE 300 4T	
4	F40218	1		INGRANAGGIO 5a A.P. Z20 6 ALETTE 300 4T	
5	F19524	5		GABBIA A RULLI 22X26X10 TAGL.	NEEDLE BEARING 22 X 26 X 10
6	48253	1		SPESSORE CAMBIO 17X30X1 250	SPACER, GEAR BOX 250cc 17X30X1
7	F49869	5		SEEGER SW 24 (EST.) "SEEGER"	CIRCLIP SW 24 (EXTERNAL)
8	F40217	1		INGRANAGGIO 3/4a A.P.Z16/20 6 ALETTE 300 4T	
9	48258	5		SPESSORE DENT.CAMBIO INT.55 6M	SPACER GEAR INT.55 6S
10	F40219	1		INGRANAGGIO 6a A.P. Z22 6 ALETTE 300 4T	
11	F40216	1		INGRANAGGIO 2a A.P. Z15 6 ALETTE 300 4T	
12	F40220	1		ALBERO SECONDARIO 6 ALETTE 250/300 4T	
13	F40222	1		INGRANAGGIO 2a A.S. Z27 6 ALETTE 300 4T	
14	F40226	1		INGRANAGGIO 6a A.S. Z20 6 ALETTE 300 4T	
15	F40223	1		INGRANAGGIO 3a A.S. Z24 6 ALETTE 300 4T	
16	F40224	1		INGRANAGGIO 4a A.S. Z23 6 ALETTE 300 4T	
17	F40225	1		INGRANAGGIO 5a A.S. Z21 6 ALETTE 300 4T	
18	F48353	1		SPESSORE PS 18X25X1	SPACER
19	F19514	1		GABBIA A RULLI 18X22X10	NEEDLE CAGE 18X22X10
20	F40221	1		INGRANAGGIO 1a A.S. Z31 6 ALETTE 300 4T	
21	48012	1		RASAMENTO A/S M/M SPESS.0,5	SPACER, 26x17x0,5
22	F03368	2		CUSCINETTO 62/22 C3 22x50x14	BUSH, 62/22 C3 22x50x14
23	49603	1		RONDELLA M 6,4 X 12 X 1,6	WASHER 6x12
24	49480	1		VITE TCEI 6X10 UNI 5931	BOLT TCEI 6X10
25	03254	1		CUSCINETTO A.P.4 Tempi 2RS1/C3	BUSH, MAINSHAFT 2RS/C3 4S
26	F03367	1		CUSCINETTO 6003 TN9C3 17x35x10	BUSH, 6003 TN9 C3 17x35x10
27	49217	1		SEEGER E22 ANELLO ALB/S	CIRCLIP D.22 - COUNTERSHAFT
28	F12320	1		O RING BOCCOLA PIGNONE 250/09	O-RING NBR 2087



**4T300FIMX25**  
**4T 300 Fi MX - 4S 300 Fi MX**

**CAMBIO**  
**GEAR BOX**

**9**

Pos.	Codice	Q.tà	Note	Descrizione	Description
29	F26421	1		DISTANZ. PIGNONE CATENA 250N	SPACER SPROCKET CHAIN 250N
30	04113	1		PARAOLIO 28 X 38 X 7	OIL SEAL 28 x 38 x 7
31	F40889	1		PIGNONE CATENA 250N - Z13	SPROCKET 13T, DRIVE 250Fi
31	F40933	1		PIGNONE CATENA 250N - Z14	SPROCKET 14T, DRIVE 250Fi
31	F40956	1		PIGNONE CATENA 250N - Z12	SPROCKET 12T, DRIVE 250Fi



4T300FIMX25  
4T 300 Fi MX - 4S 300 Fi MX

### CENTRIFUGATORE AVVIAMENTO

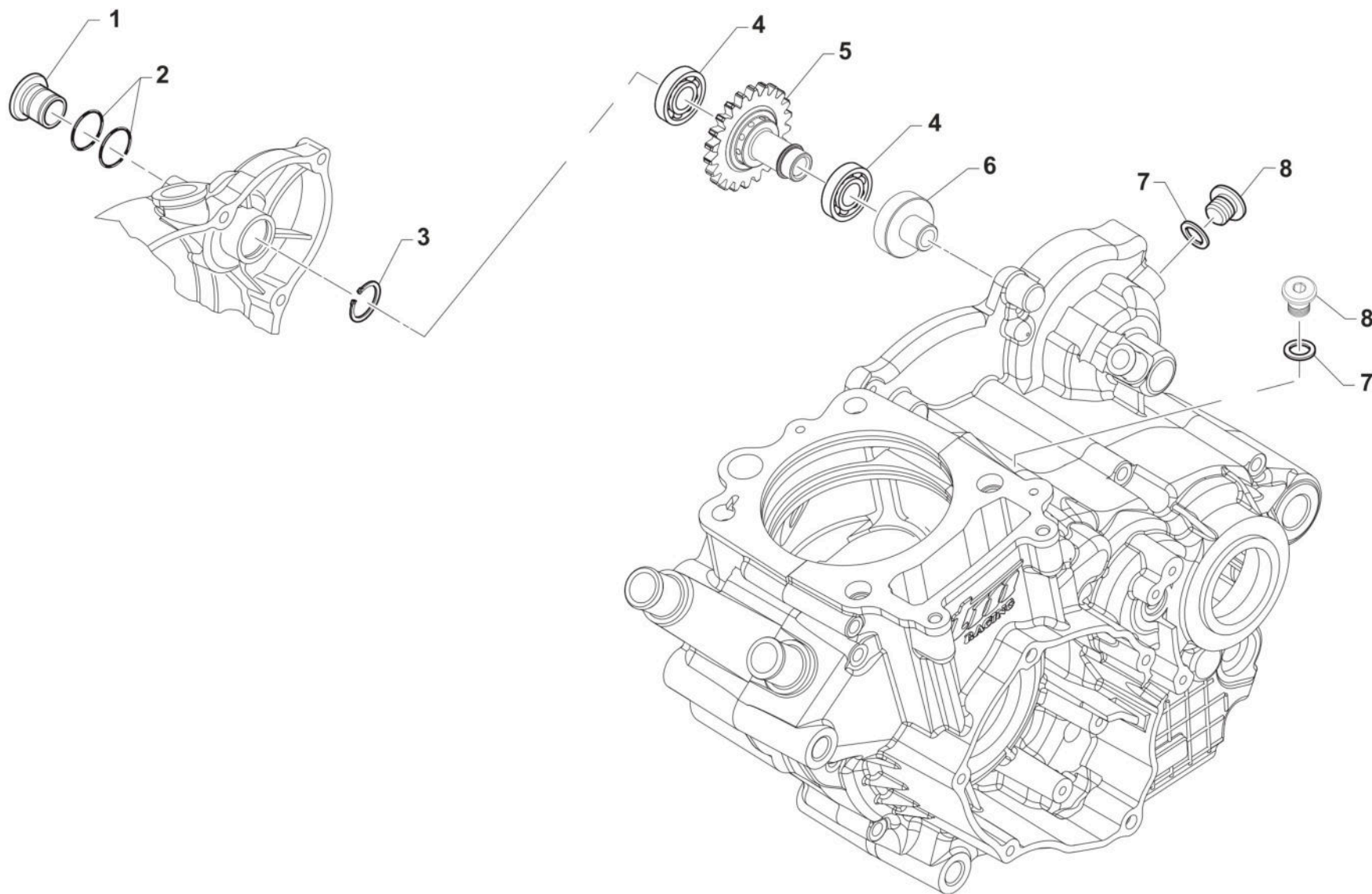

TM 0010.01



4T300FIMX25

4T 300 Fi MX - 4S 300 Fi MX

CENTRIFUGATORE AVVIAMENTO

10

Pos.	Codice	Q.tà	Note	Descrizione	Description
1	26234	1		TAPPO FORO ALBERINO M/M 250/300 4T	
2	12092	2		O RING NBR14x2 REGISTRO ALTE VELOCITA'	
3	F49914	1		SEEGER E 18	CIRCLIP E D.18
4	03149	2		CUSCINETTO 61902-2RS1/C3	
5	40223	1		INGR. CENTRIFUGATORE Z24 300 4T	
6	F26518	1		SUPPORTO CUSCINETTO 61902	
7	F49939	2		RONDELLA RAME 8 X13 X 1,5	WASHER COPPER 8,5X13X1,5
8	F49823	2		TAPPO ALBERINO ROT.BILANC.250N e CARTER	PLUG, SHAFT 250N

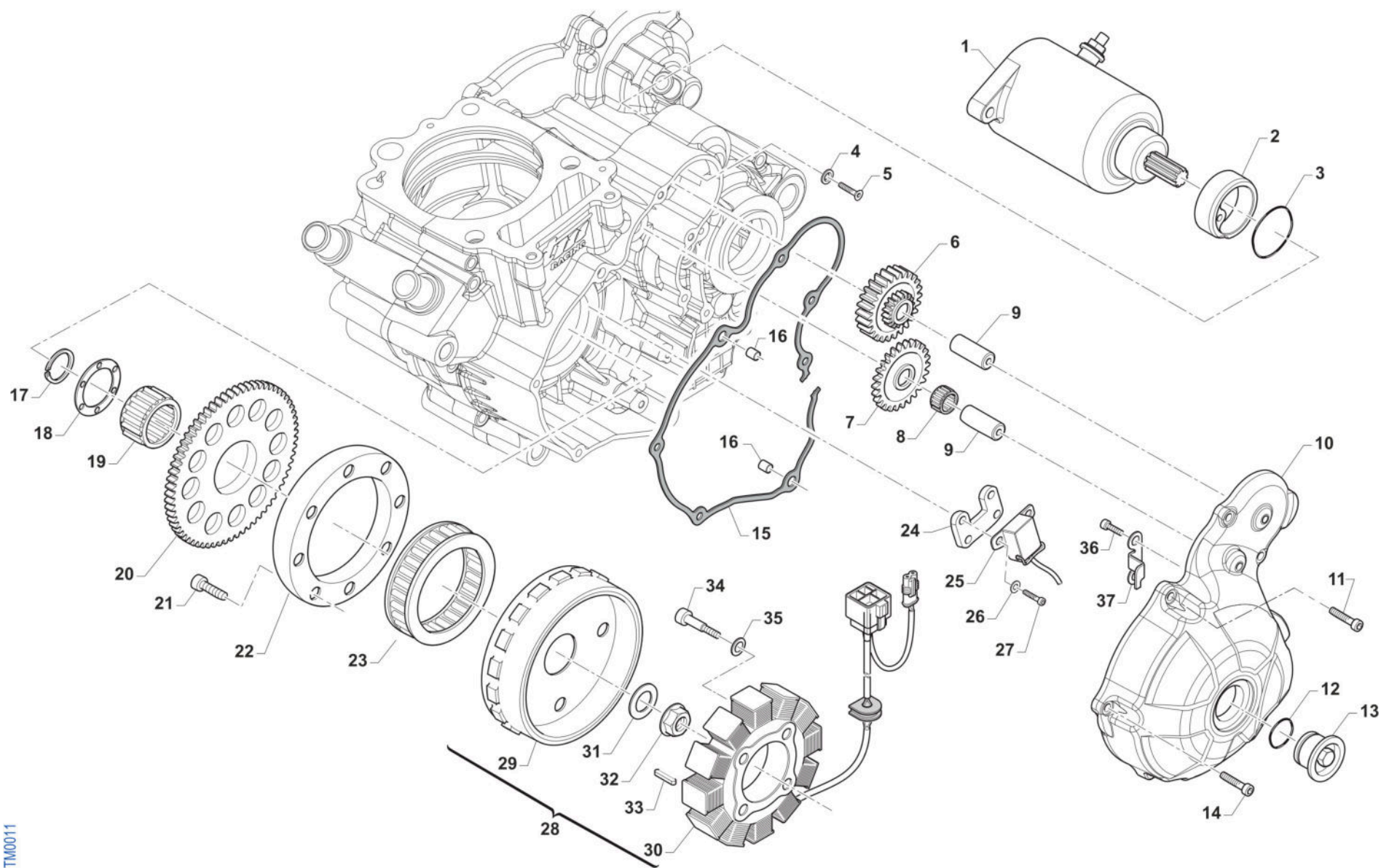



**4T300FIMX25**  
**4T 300 Fi MX - 4S 300 Fi MX**

**ACCENSIONE ES (4 FORI)**

Pos.	Codice	Q.tà	Note	Descrizione	Description
1	F68145	1		MOTORINO AVVIAMENTO 250N M08 SM 14 A8323-048-00-000	E-STARTER ENGINE 250 4 S 08->
2	F26341	1		BOCCOLA CENTRAGGIO MOT.AVVIAM.	COLLAR, EL. STARTER
3	F12309	1		O RING 2150	O-RING, 2150
4	49675	1		RONDELLA 7 x 13,9 x 1,5	
5	49399	1		VITE TSEI 5X12	BOLT TSEI 5x12
6	40224	1		INGRANAGGIO DOPPIO 4T ESSOSTITUISCE F40839	GEAR, DOUBLE, ELECTRIC STARTER REPLACE CODE F40839
7	F40808	1		INGR. FOLLE AVVIAMENTO EL.	INTERMEDIATE GEAR
8	F19501	1		GABBIA A RULLI 10X13X10 4T	NEEDLE CAGE 10X13X10 F.S.
9	F28568	2		ALBERINO LUNGO ING. AVV.ELETTR	SHAFT, EL. STARTER GEAR
10	F30963	1		COP. ACC. 250Fi MX/ES 10/-> ATTACCO ACCENSIONE 4 FORI	COVER IGNITION 250Fi MX/ES10->
11	49477	2		VITE TCEI 5X25 UNI 5931-912	BOLT TCEI 5X25
12	F12322	1		O RING 2106	O-RING
13	F49833	1		TAPPO COPERCHIO ACC.250Fi	COVER CAP ALUMINIUM 250Fi
14	49476	5		VITE TCEI 5X20 UNI 5931	BOLT TCEI 5X20
15	F05829	1		GUARNIZ.COP.ACCENSIONE ES 250N	GASKET, INGNIT.COVER ES 250Fi
16	26041	2		GRANO CENTRAGGIO D.7X8 F.5,2	DOWEL PIN 7 x 8 Hole 5,2
17	F49937	1		SEEGER ALBERO E 36 4T	CIRCLIP 36 CRANKSH. E 4S
18	F26327	1		RONDELLA ACC. 37X53X2 4T	WASHER 37X50X2 4S.
19	F19506	1		GABBIA A RULLI AVV.EL.37X42X17	NEEDLE CAGE 37X42X17 E.S.
20	F40807	1		INGR. CONDOTTO AVVIAMENTO EL.	GEAR EL. STARTER
21	F49929	8		VITE TCE BASSA 6X16 (CL. 12.9)	SCREW TCE 6 X 16
22	F26385	1		ANELLO ESTERNO PESANTE R.L.KOK	EXTERNAL RING IGNITION KOKUSAN
23	F03354	1		RUOTA LIBERA MOTORINO AVV. 4T	FREE-WHEEL ELECTRIC STARTER
24	F08075	1		PIASTRINO PICK-UP 250Fi MX/ES	
25	F15478	1		PICK-UP KOKUSAN	PICK-UP KOK PU5157
26	49601	2		RONDELLA 5X11	WASHER 5x11



4T300FIMX25

4T 300 Fi MX - 4S 300 Fi MX

ACCENSIONE ES (4 FORI)

11

Pos.	Codice	Q.tà	Note	Descrizione	Description
27	49542	2		VITE TCEI 5X10 UNI 5931	BOLT TCEI 5 X 10
28	F15561	1		GENERATORE KOKUSAN MX E.S. KOK / SUMIT. 2V	GENERATOR KOKUSAN MX E.S.
29	F15549	1		ROTORE KOKUSAN YF9019	ROTOR, KOKUSAN YF9019
30	F15547	1		STATORE KOKUSAN YS 9018 C. KOK / SUM	
31	49613	1		RONDELLA ACCIAIO 12	STEEL WASHER 12
32	49056	1		DADO ACCENSIONE MX/E 12 x 1.25	NUT, IGNITION 100cc
33	F49853	1		CHIAVETTA 5X3X25 UNI7510R.F.A.	WOODRUFF KEY, 5x3x25
34	49384	4		VITE TCEI 4X35	
35	49866	4		RONDELLA 4 x 12 x 1	
36	49553	2		VITE TCEI 4X8 5931-912 Brun	BOLT TCEI 4X8
37	F30945	1		PROTEZIONE CAVI ACC.NE 250N	PROTECTION IGNITION WIRES 250N





4T300FIMX25  
4T 300 Fi MX - 4S 300 Fi MX

MONO TM 4T MY 2020

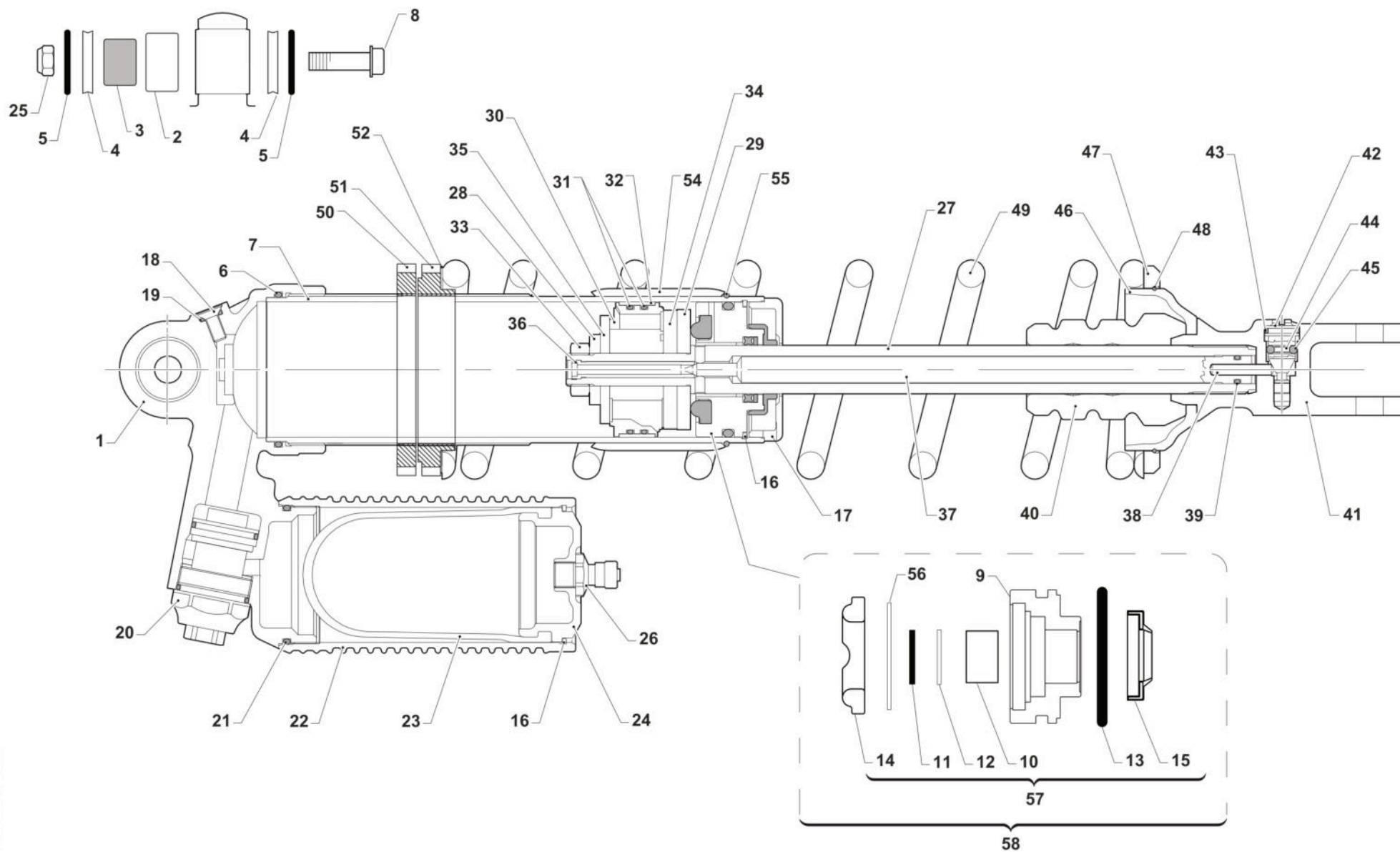



4T300FIMX25  
4T 300 Fi MX - 4S 300 Fi MX

MONO TM 4T MY 2020

Pos.	Codice	Q.tà	Note	Descrizione	Description
1	F72502	1		TESTINA MONO TM 4T 2018	
2	19101	1		GABBIA RULLINI DL 1812 KYU	BUSH NEEDLE CAGE DL 18/12
3	73213	1		BOCCOLA 18 X 12.3 F.10 TRIANG. + MONO	BUSH, 18 X 12.3 X 5
4	F26536	2		SPESSORE PER TESTINA AMM.RE TM	SPACER, TM SHOCK HEAD
5	12058	2		O RING TESTA AMMORTIZZATORE	O-RING SHOCK HEAD TM
6	12027	1		O RING TENUTA CORPO AMMORT. TM	O-RING SHOCK BODY TM
7	F72527	1		TUBO CORPO MONOAMMORTIZ.TM M57	SHOCKBODY TM M57
8	49792	1		VITE TE F/R 10X54 1.25 T.AL08	BOLT, M10X1.25X54 ALU.FRAME08
9	F72529	1		GUIDASTELO MONO TM	HEADSHAFT TM SHOCK ABSORBER
10	72252	1		BOCCOLA SCORRIM. ASTA AMMOR.1812	
11	F04387	1		ANELLO DI TENUTA STELO MONO TM	
12	F48399	1		RALLA SPALL.TO BOCCOLA ST.MONO	
13	F12333	1		O-RING NBR (42.86x3.53)	
14	F72402	1		TAMPONE F.C.ESTENSIONE AMMORT.	
15	F04374	1		PARAPOLVERE AMMORTIZZATORE TM	DUST SEAL TM MONOSHOCK
16	49268	2		SEEGER SB 50 (PER FORI)	SEEGER SB 50
17	F72350	1		COPERCHIO MONOAMM. 250N TM	
18	49944	1		VITE TS 5X12 TORX	
19	F12306	1		O RING 2018-13 CARB.D.32-40 4T	
20	72406	1		VALVOLA COMPRESSIONE MONO TM	COMPRESSION VALVE TM MONOSHOCK
21	12273	1		O RING ORM 0430-30 VITON	
22	F72453	1		BOMBOLETTA MONOAMM. TM MAGG.	
23	F72452	1		BLADDER MAGG. AMMORTIZZ. TM	
24	F72455	1		TAPPO BOMBOLETTA MONO TM SB50	GAS TANK CAP RR SHOCK ABS. TM
25	49681	1		DADO M 10 X 1,25 CH 14 FLANG. AUTOBLOCK	NUT M10x1,25 FLANGED SELF-LOCK
26	F72381	1		VALVOLA GONFIAGGIO BOMBOLETTA	VALVE, SHOCK ABSORBER TM
27	F72456	1		STELO AMMORTIZZATORE TM +8mm	SHAFT SHOCK ABSORBER TM +8mm
28	F72405	1		RONDELLA D.12x26x4	



4T300FIMX25  
4T 300 Fi MX - 4S 300 Fi MX

MONO TM 4T MY 2020

3

Pos.	Codice	Q.tà	Note	Descrizione	Description
29	F72404	1		RONDELLA D.12x44.5x5	
30	F72372	1		PISTONE AMMORTIZZATORE TM	
31	F12328.1	2		O-RING PIST. AMMORTIZ. 42,5X2,00 FPM70 NERO	
32	F72401	1		ANELLO TENUTA PIST.AMMORT.D.50	OIL SEAL SHOCKABSOBER PIST.D50
33	F49848	1		DADO M12x1,25 - AMMORT.TM	
34	F72407	1		PACCO LAMELLE COMPRESSIONE 4T	
35	F72408	1		PACCO LAMELLE ESTENSIONE 4T	
36	F72406	1		UGELLO FRENATURA ESTENS.MONOAMM	PISTON ROD NEEDLE
37	F72457	1		ASTINA FRENA ESTENS.AMM.TM+8mm	REBOUND ADJUSTER ROD S.A.TM+8
38	F72371	1		PUNTALE PER ASTINA MONO TM STD	
39	12056	1		O RING ASTINA MONOAMMORTIZ. TM	
40	F72403	1		TAMPONE F.C.COMPRESS.AMMORTIZ.	BUMP RUBBER TM SHOCK ABSORBER
41	F72362	1		PIEDINO A FORCH. MONOAMM.TM 4T + 2T/2022	
42	F72368	1		REGISTRO ESTENSIONE AMM.RE TM	
43	F12319	1		O RING RITORNO MONO TM	
44	F16455	1		MOLLA BLOCCAGGIO REGIST.ESTENS	
45	19057	2		SFERA D. 3 mm	
46	F72485	1		BICCHIERE PORTA-MOLLA MONO C.E	
47	F72366	1		FLANGIA PORTA-MOLLA MONOAMM.	
48	F49845	1		ANELLO DI RITEGNO X ALBER.D.60	
49	F72351	1		MOLLA MONOAMM. TM ACC. K=44	SPRING MONOSHOCK TM STEEL K=44
49	F72352	1		MOLLA MONOAMM. TM ACC. K=46	SPRING MONOSHOCK TM STEEL K=46
49	F72353	1		MOLLA MONOAMM. TM ACC. K=48	SPRING MONOSHOCK TM STEEL K=48
49	F72354	1		MOLLA MONOAMM. TM ACC. K=50	SPRING MONOSHOCK TM STEEL K=50
49	F72355	1		MOLLA MONOAMM. TM ACC. K=52	SPRING MONOSHOCK TM STEEL K=52
49	F72398	1		MOLLA MONOAMM. TM ACC. K=54	SPRING MONOSHOCK TM STEEL K=54
49	F72399	1		MOLLA MONOAMM. TM ACC. K=56	SPRING MONOSHOCK TM STEEL K=56
49	F72423	1		MOLLA MONOAMM. TM ACC. K=42	SPRING MONOSHOCK TM STEEL K=42



4T300FIMX25

4T 300 Fi MX - 4S 300 Fi MX

MONO TM 4T MY 2020

3

Pos.	Codice	Q.tà	Note	Descrizione	Description
49	F72458	1		MOLLA MONOAMM. TM ACC. K=58	SPRING MONOSHOCK TM STEEL K=58
49	F72459	1		MOLLA MONOAMM. TM ACC. K=60	SPRING MONOSHOCK TM STEEL K=60
49	F72460	1		MOLLA MONOAMM. TM ACC. K=62	SPRING MONOSHOCK TM STEEL K=62
49	F72462	1		MOLLA MONOAMM. TM ACC. K=40	SPRING MONOSHOCK TM STEEL K=40
50	72421	1		GHIERA INF. PREC. MOLLA MONO TM'18 2T/4T	NUT FOR SPRING BOTTOM TM 2S 4S
51	72420	1		GHIERA SUP. PREC. MOLLA MONO TM'18 2T/4T	NUT FOR SPRING TOP TM 2S 4S
52	72089	1		RONDELLA MONO TM 75X60.75 X0.3	WASHER, MONOSHOCK TM 0,3
54	F26548	1		BOCCOLA PROT.CORPO MONOAMM. TM	SHOCK TM BODY PROTECTION
55	F49852	1		ANELLO RITEGNO X ALB. D.54.2	STOP RING SHOCK BODY TM
56	F48398	1		RALLA SPA.GUARN.F04387 MONO TM	
57	72409.19	1		KIT REVISIONE GUIDASTELO MONO TM MY19	TM MONOSHOCK SEAL HEAD REVISION MY19->
58	72422	1		GUIDASTELO MONO TM CPL M. 19->	SHOCK SEAL HEAD ASSY MY19->



4T300FIMX25  
4T 300 Fi MX - 4S 300 Fi MX

### CORPO FARFALLATO THROTTLE BODY

19

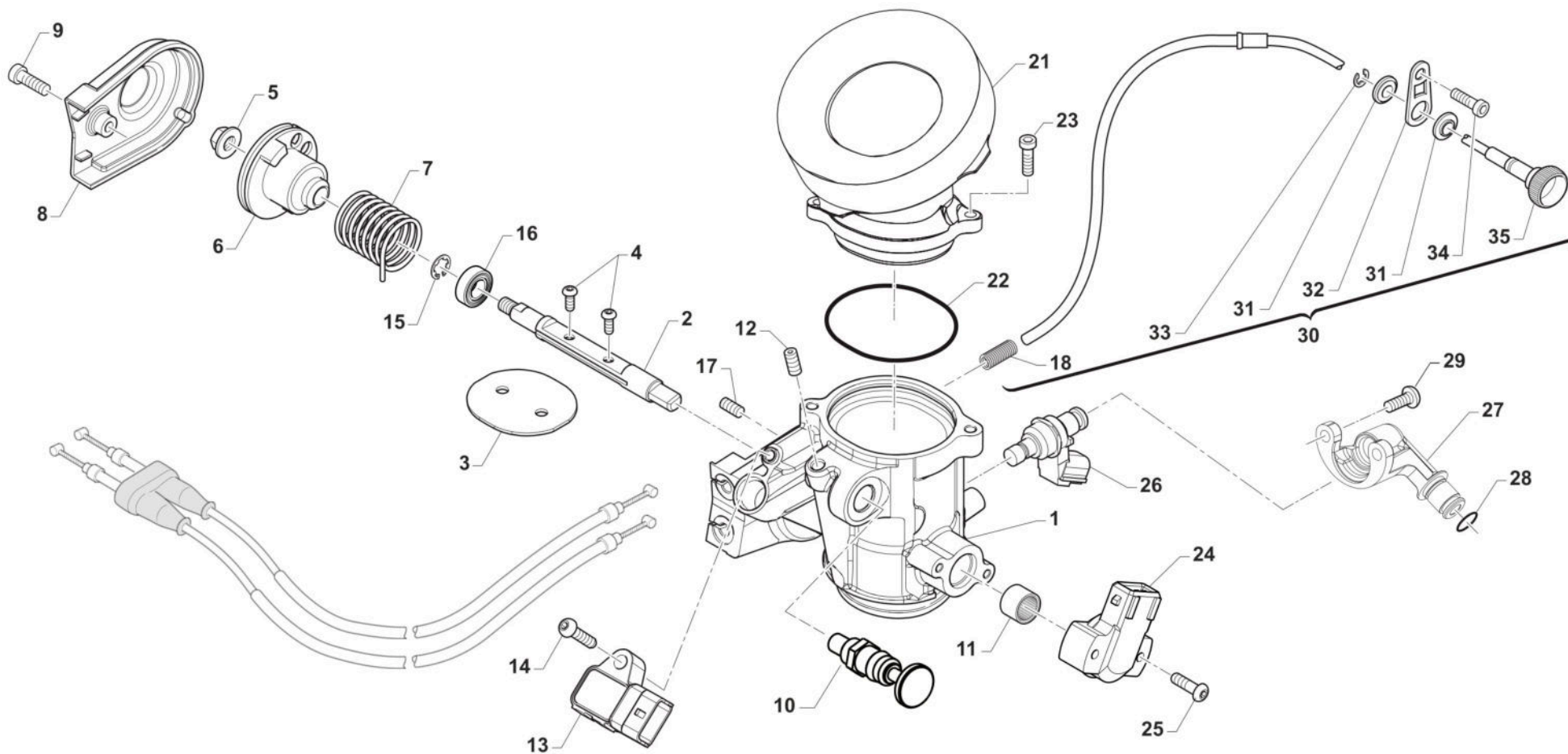

TM 0013.06



**4T300FIMX25**  
**4T 300 Fi MX - 4S 300 Fi MX**

**CORPO FARFALLATO**  
**THROTTLE BODY**

**4**

Pos.	Codice	Q.tà	Note	Descrizione	Description
1	08121	1		CORPO FARFALLATO MOTORE 4T	
2	F08354	1		ALBERINO CORPO FARFALLATO 250R	
3	F08355	1		FARFALLA 250	
4	49728	2		VITE TBCIX 4X6	BOLT
5	49676	1		DADO M 6X1 FLANG. AUTOBL.ACC.	NUT, FLANGED M6 X 1 S.B.
6	F08353	1		PULEGGIA CORPO FARFALLATO 125/250	PULLEY
7	F16478	1		MOLLA COMANDO GAS 250 REPLICA	SPRING
8	F08051	1		COP. CORPO FARFALLATO 44-47	COVER THROTTLE BODY ASSY 44-47
9	49470	1		VITE TCEI 4X12	BOLT TCEI 4X12
10	D24112	1		DISPOSITIVO ARIA KEIHIN REDCAP	CHOKE KNOB ASSY KEIHIN REDCAP
11	F19542	1		ASTUCCIO A RULLI HK1012 2RS	NEEDLE BEARING
12	F49919	1		GRANO 6X 6 ESTREM.PIATTA 4T	GRUB, 6 X 6 4 Str.
13	F08072	1		PRESSURE SENSOR	SENSOR, PREASSURE
14	49754	1		VITE TBCIX 5X20	BOLT TBCIX 5x20
15	F49054	1		SEEGER JK20 CUSC. ALB. C. FARF. 250 Fi	SEEGER
16	F03389	1		CUSCINETTO 8X16X5 628/8 2RS	BEARING
17	F49055	1		GRANO M4 x 4mm PUNTA PIATTA	GRUB SCREW M4 x 4 FLATHEAD
18	F16452	1		MOLLA PER COMANDI FLES.C.FARF.	SPRING ADJUSTING IDLE SPEED TB
19	08140	1		CORPO FARFALLATO CPL 4T 300 Fi EN/MX MY 2025	
21	F08409	1		TROMBETTA 300 4T REPLICA 2020	
22	F12382	1		O-RING 0510-20 51.0X2.0 FKM	
23	49890	2		VITE TBCEI 5 x 14 UNI 7380 10.9	SCREW TBCE 5X14
24	F08052	1		POTENZIOMETRO HELLA 008476-111	POTENTIOMETER HELLA
25	49928	2		VITE TBCIX 4X25	BOLT
26	F08322	1		INJECTOR N5J 445cc W/OUT D.	
27	F08485	1		SUPPORTO INIETTORE 4T 450/530 MX 2022 250/300 2025	
28	F12321.1	1		O RING INNESTO TUBO BENZ. C/F 250Fi MX	O RING FUEL HOSE THROTTLE BODY 250Fi MX
29	F49056	2		Vite a testa bombata cava esalobata TX M5x12	



4T300FIMX25  
4T 300 Fi MX - 4S 300 Fi MX

CORPO FARFALLATO  
THROTTLE BODY

4

Pos.	Codice	Q.tà	Note	Descrizione	Description
30	F64331	1		CORDA REGISTRO R.MIN.250Fi CPL	CABLE IDLE ADJUSTMENT 250Fi
31	F64330	1		BOCCOLA SUPP.REG.MIN.CORP.FARF	
32	F64329	1		PIASTR.SUPP.REG.MIN.CORP.FARF.	
33	F49938	1		SEEGER RS5 (DECOMPRESSORE)	
34	49470	1		VITE TCEI 4X12	BOLT TCEI 4X12
35	F64328	1		CORDA REGISTRO R.MIN.X C.FARF.	CABLE ADJUSTING IDLE SPEED TB